

V35 Round Line

Complete 360° Label & Package Inspection



Label Check 360°

Inspect label quality, text, or other graphic identification to prevent label and package mix-up. System ensures that correct labeling is applied when managing product changeovers on high-speed production lines.



Code Check 360°

Verify 1D and 2D barcodes, alpha-numeric text presence and print quality on the label. Verify end of line inkjet print is presented perfectly – reject products with smeared, misprinted or missing information.



Cap and Fill Check

Inspect cap or lid presence, color, and skew to ensure top packaging components match side label packaging. Detect fill levels on transparent containers to minimize overfill and eliminate under filled product.



Easy-to-use Software

Intuitive touch screen interface and standard configuration of inspection tools, simplifies new product setup saving you time and money.



Vision Inspection of Round Products

The METTLER TOLEDO V35 Round Line is a turnkey inspection solution for round, un-oriented containers which utilizes a simpler, more accurate vision processing method than traditional 360° inspection solutions.

- **Compact** – The breakthrough design puts 6 cameras into a slim package, allowing the system to fit on crowded production lines.
- **Accurate** – Our state-of-the-art inspection routines ensure labels and prints are present and correct on round un-oriented packages and products.
- **Washdown** – Stainless steel design makes it ideal for use in washdown environments, conforming to IP65 specifications.

V35 Round Line

Technical Specifications



Typical Containers – Round and Unoriented etc.

Applications

Containers fill control, label inspection, package integrity, label/cap inspection, label mix-up prevention

Inspection Capabilities

- 1D and 2D barcode presence, reading and verification
- Alpha-numeric text presence, reading and verification
- Presence and quality of graphics
- Label position (Y position)
- Label quality (flags, holes, tears)
- Label verification
- Cap print and label inspections possible with top-down camera

Software Capabilities

- Failure string signals: The V35 Round Line system can be programmed to signal operators or shut down production based on production trends or a set of consecutive failures, allowing for early detection of weak points in the production process.
- Anti-circumvention capabilities provide a safeguard against bypassing inspection to speed up production – making sure that every product gets inspected.
- CIVCore interface is standard on all METTLER TOLEDO CI-Vision turnkey systems.

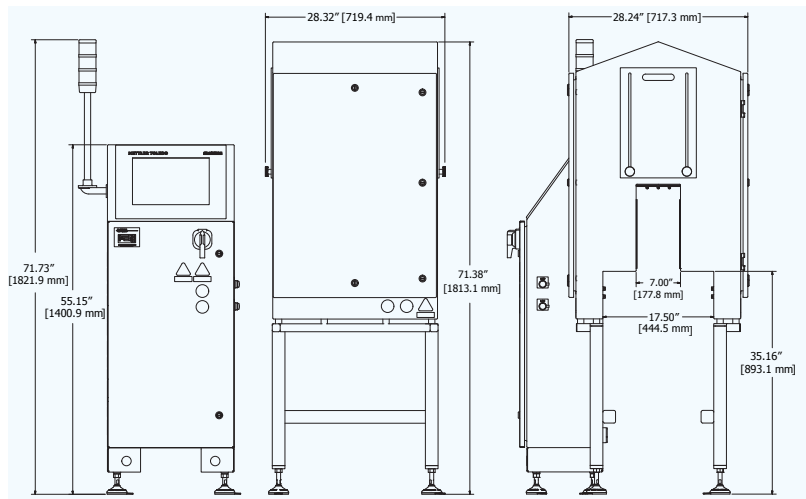

Schematic – V35 Round Line front view...

and side view (typical dimensions)

Choosing the Right System

Every manufacturer has their own specific needs and their own quality assurance processes to follow. METTLER TOLEDO CI-Vision has a system configuration to meet the needs of manufacturers regardless of container size. Speak to a METTLER TOLEDO CI-Vision sales representative to find the right system for your needs.

Model	V35 Round Line
Min Inspection Area (h x w)	75 x 60 mm
Max Package Dimensions (h x d)	200 x 125 mm (8" x 5")
Max Inspection Area (h x w)	165 mm x 125 mm (6.5"x5")
No. of Cameras	Up to 8
No. of Lights	Up to 8
Inspection Throughput	1000 ppm
Vision Technology	PC Controlled GigE Cameras
Power Requirements	110 - 230 V (single phase), 50-60 Hz
Operating Temperature (no A/C)	<80 °F (20 °C), <80 % humidity
Ingress Protection	IP65

Note: The system has additional options that can be configured to your production line. Contact us today to get a quote.

METTLER TOLEDO Service with global reach and tailored care solutions



Mettler-Toledo Group

Product Inspection Division
Local contact: www.mt.com/contacts

Subject to technical changes.
Images are examples only.
©01/2019 METTLER TOLEDO. All rights reserved.
PI-VI-DSHEET-V35ROUNDLINE-EN

www.mt.com/ci-vision

For more information