

## Ergonomic and space-saving Increased space for sales transactions



### Bright displays

Clear and easy to read: The customer and operator displays of the bC-H22 have an anti-glare, anti-reflection display screen with a wide reading angle. The adjustable backlight ensures a high-contrast display even in the case of poor lighting conditions.



### Simple paper changing

The removable printing unit facilitates a simple and rapid paper change, while the print head is easily accessible for cleaning. The receipt or label roll is fitted below shoulder height and thus prevents wet sleeves during operation caused by flowing water.

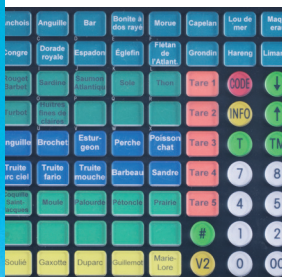

### Fast operation

The bC-H22 hanging scale provides the highest level of operating convenience with the tried-and-tested METTLER TOLEDO Light Touch keyboard. The removable keyboard is simple to clean, while the freely configurable keys can be individually labeled.



### Targeted sales promotion

Take advantage of the scale housing for your advertising campaigns: Advertising images and messages can be displayed on the customer's side of the screen at ease. In this way, you can really draw attention to your offers.



### Compact housing

All interfaces and connections as well as the antennae of the WiFi unit available as an option are safely protected against dirt and damages thanks to the easily removable plastic ABS cover.



### bC-H22 hanging scale

Professional hanging scale with a compact design

The METTLER TOLEDO bC-H22 hanging scale is the classic weighing solution for fish and perfect for counters where little space is available for presenting fresh produce. Thanks to its suspended design and the hard-wearing plastic ABS housing, the electronics of the scale are optimally protected against spills, acids, salt and oils. The key to a successful sales pitch: the slimline housing does not block the customer's view and eye contact can be maintained at all times.

The bC-H22 hanging scale has a printer for receipts or labels and can be networked with all modern scales from METTLER TOLEDO's bC scale family as standard.

**METTLER TOLEDO**

Tactile bC Retail Scales  
**bC-H22 hanging scale**

- Robust and powerful – for professional requirements**
- Space-saving suspended design – creates more space for sales transactions**
- Compatible with the bC scale family – a future-proof investment**
- Receipt and label printer as standard – versatile usage**

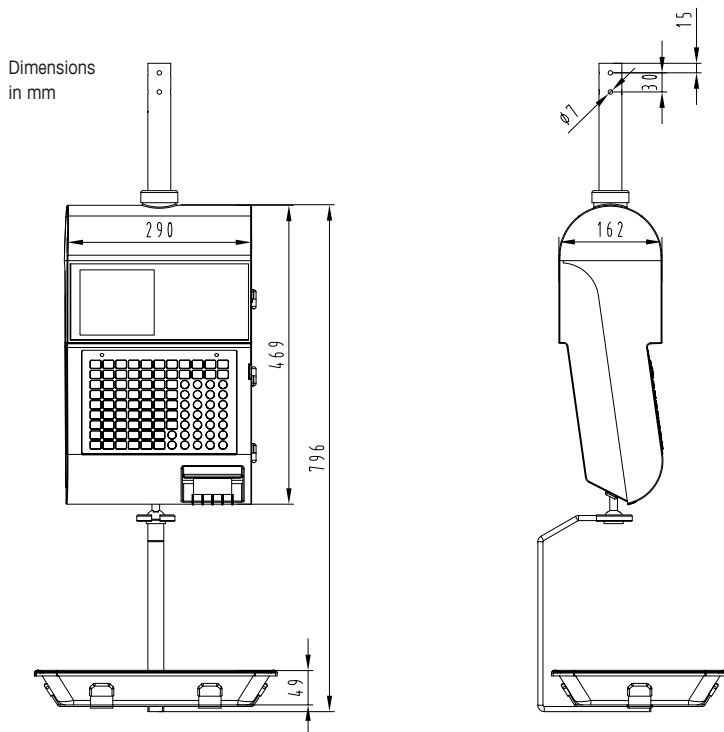

**Display**  
 High resolution back-lit LCD  
 Weight: 5 locations  
 Tare: 5 locations  
 Basic price: 7 locations  
 Total price: 7 locations  
 Text line: 16 alphanumeric characters  
 240 x 240 dot matrix display (optional)

**Functions**  
 Serving function, cash register function, inventory function, large-volume sales, self service and training function, service function with receipt, label, total label, self-adhesive total receipts.

**Keyboard**  
 Patented Light Touch keyboard  
 99 keys in total, 30 function keys  
 69 freely programmable fixed keys  
 Easy to maintain thanks to the patented, removable Light Touch keyboard

**Printer**  
 2" print head for receipts/label printing  
 Thermal printer 125 mm/s, logo printed onto receipts and labels,  
 10 freely definable labels, large number of predefined labels

**Interfaces**  
 RJ45, Ethernet TCP/IP  
 2 serial interfaces  
 RJ11 connection for cash register drawers  
 1 USB port  
 Optional: Integrated WLAN IEEE802.11b/g

**Data storage**  
 4 MB application memory is sufficient for even the toughest demands on speed of use  
 3 MB data memory with additional expansion options up to a maximum of 8 MB

**Secure weighing**  
 Password login for staff members  
 Electronic journal  
 Price changes and sales reports protected by pin codes

**Reporting**  
 Adjustable daily reports  
 Reporting on two revenue levels  
 Electronic journal  
 Reports per staff member, department, category, item, price, revenue report for specifically defined time frames

Weighing range	15 kg	6/15 kg	12 kg
Graduation	5 g	2/5 g	2 g
Minimum capacity*	100 g	40 g	40 g

Automatic zero setting  
 \* EG: Printout under minimum capacity possible, but not with price marking.

[www.mt.com/retail](http://www.mt.com/retail)

For more information



Quality certificate ISO 9001  
 Environmental certificate ISO 14001  
 Conformité Européenne  
 Worldwide service

Subject to technical changes  
 © 10/2009 Mettler-Toledo AG  
 Printed in Germany 22020761  
 Global MarCom Switzerland