

# Weighing and Ticket Printing Scale

## Functional. Durable. Economical.



bMobile Compact Scale

**With quick and accurate weighing and service, bMobile from METTLER TOLEDO is an economic price computing scale with a receipt printer that is designed to make your life simpler. It is a functional scale based on years of experience in leading scale technology.**

bMobile represents an easy-to-service solution for all mobile shops and chain stores. The scale is fast enough for your weighing requirements even during peak hours, and durable due to its high-quality components. An optional battery kit makes offers complete independence from power sources.

**METTLER TOLEDO**

# bMobile

## Make Your Life Simpler

**bMobile is the perfect choice for grocery retailers looking for an easy-to-use, reliable scale with basic and advanced weighing and ticket printing functions. bMobile boosts sales right from the start: set up the network connection, transfer existing data to your new scale and configure its keyboard according to your needs in no time at all.**

bMobile allows retailers to track and trace the status of transactions in real time. Sales staff will appreciate the easy and straight-forward handling of bMobile and its intuitive workflows. bMobile combines smart scale management and simple ergonomic operation with accurate, quick weight stabilization.

### Functional



Convenient data mobility via USB. Access the USB host as a simple and convenient way to transfer and back-up data (e.g. item data, configuration). Operate independently from plugs and power grids with rechargeable batteries (optional), or make use of the floating vendor function (optional).

### Durable



With its aluminum-based housing construction and its stainless-steel platter, bMobile offers maximum durability, even under harsh retail environments like extreme temperatures, moisture and dust. Ensure food safety compliance with its easy-to-clean design and germ-resistant housing.

### Economic



Flexibility with affordability. bMobile's basic functions include an evolving software platform, giving retailers the flexibility to add optional functions and updates precisely in line with your customized needs. Its affordable price point makes it the perfect solution for an optimized return on investment.

### Hygienic design

The stainless-steel weighing plate provides stability with its strong torsion. It is rust-proof, easy to clean and ensures compliance with food safety regulations. bMobile's insect-proof design makes it ideal for outdoor markets.

### Lower energy costs

bMobile reduces power consumption to <math><0.5\text{ W}</math> by automatically switching to energy-saving standby mode during longer pauses between uses. A quick touch of any key is all it takes for the scale to be ready for action again.

### Fast ticket printing

Reduce customer wait times with bMobile's high-speed thermal printer of 80 mm/sec.

### Easy height adjustment

bMobile comes with easy adjustable rubber feet to guarantee stability and accuracy.

### Enhanced mobility

A rechargeable battery kit is optionally available, enabling stores to operate bMobile independent from a power source. The battery kit is a perfect match for market stalls and in environments affected by frequent power outages.

### Fast network-setup

With automatic IP setup, bMobile offers a simple and convenient way to set up the network.

### Flexible keyboard layout

bMobile offers 35 individually configurable preset keys to map PLUs or different functions. Each key can be doubly assigned to give sales employees quick access to the product range.

### Convenient data management

The scale comes with a simple and convenient way to transfer and back-up data from/to USB. Configurations and software updates can be done quickly and easily.

**For more information visit:**  
[www.mt.com/retail-bMobile](http://www.mt.com/retail-bMobile)

### Designed for open market stalls, mobile sales activities and busy retail environments

- Compliance – Support specific fiscal data collection according to local EU regulations.
- Customer Tare – Strengthen customer loyalty by allowing shoppers to bring their own containers.
- Optional Extra Features – Allows the scale's features to evolve with your business development.
- Data Mobility via USB – Quick and easy daily PLU price updates for mobile businesses.
- User Rights Management – Full price management control and influence on business margins.



# Technical Data

## bMobile

### Operator Display

- One line dot matrix LCD display with white backlight
- Weight: 6 digits
- Tare: 5 digits
- Price/kg: 6 digits
- Total: 7 digits
- Text line: 16 alphanumeric characters, dot matrix line (16 × 192 dots)

### Customer Display

- One line dot matrix LCD display with white backlight
- Weight: 6 digits
- Tare: 5 digits
- Price/kg: 6 digits
- Total: 7 digits
- Text line: 16 alphanumeric characters, dot matrix line (16 × 192 dots)

### Housing

- Plastic housing with die-cast aluminum
- Stainless-steel weighing plate

### Keyboard

- Easy to clean membrane keyboard
- 63 membrane keys with pressure point
- 35 PLU preset keys

### Printer

- Thermal printer
- Printing speed: up to 80 mm/sec
- Max. print resolution per character: 8 × 16 dots
- Roll width: 57 mm
- Roll diameter: max. 68 mm

### Data Storage

- 8 MB internal memory

### Interfaces

- 1 RS232 serial interface
- 2 RJ45 Ethernet interfaces
- 4 USB 2.0 interfaces (3 USB hosts, 1 USB device)
- 1 RJ11 interface (12 V) to control a cash drawer

### Networking and Data Transfer

- 10/100 Base T Ethernet, TCP/IP, USB, DHCP
- Automatic network connection thanks to DHCP support
- No hub required for network connection
- Data transfer via USB device



### Housing Color

- Light grey

### Weighing Intervals

- 6/15 kg 15 kg 15/30 kg

### Echelon

- 2/5 g 5 g 5/10 g

### Minimum capacity

- 40 g 100 g 100 g

### Accessories and Options

- Lead acid battery kit (12 V, 5.5 Ah)
- Tower kit
- Printer axis
- Plastic cover
- Carrying suitcase

### Licenses

- Network options: 4 or 10 scales

### Power Supply

- 220 V AC, 50Hz
- Rechargeable lead acid battery for mobile and independent usage (optional)

### Operating Environment

- Temperature: -10°C – 40°C
- Humidity: 85% RH, non-condensation

### Shipping

- Gross weight: 7.7 kg
- Dimensions: 539 × 529 × 258 mm

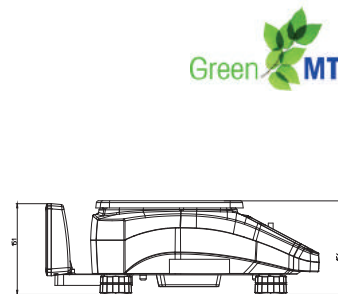
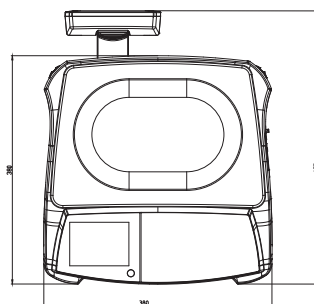

All dimensions in mm

[www.mt.com/retail](http://www.mt.com/retail)

For more information

### METTLER TOLEDO Group

Retail Division

Local contact: [www.mt.com/contacts](http://www.mt.com/contacts)

Subject to technical changes

©09/2020 METTLER TOLEDO. All rights reserved

Document No. 30521377

MarCom Industrial

