

Should you desire a different assignment of the inputs and outputs, you have the following setting possibilities in the master mode:

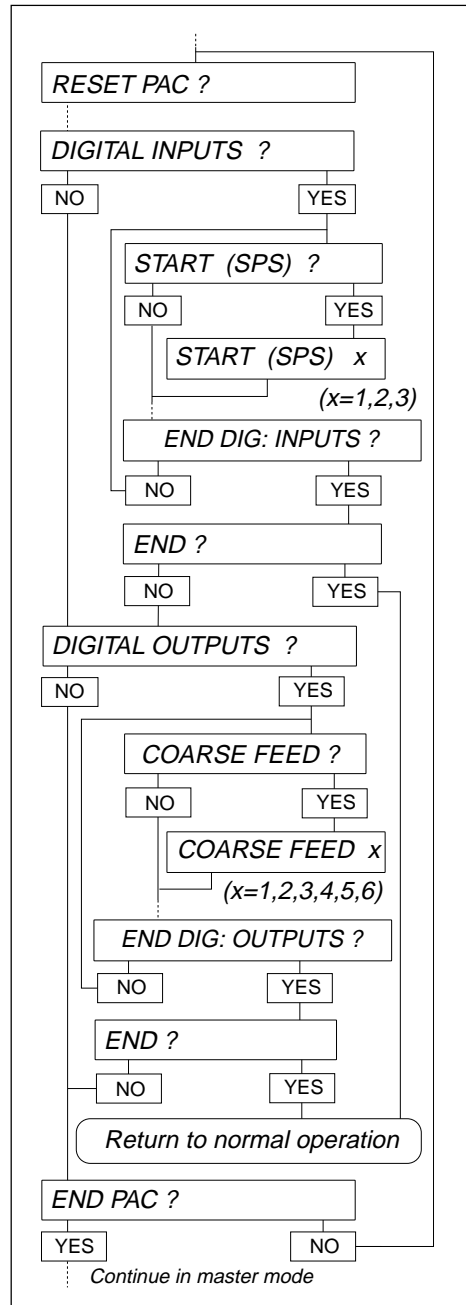

Digital inputs

- Start SPC
- Stop SPC
- Acknowledge
- Tare
- Nozzle
- Input 6

Digital outputs

- Coarse feed
- Fine feed
- Ready
- Start
- Correct
- Poor
- End dispensing
- Output 2

Procedure

- In the master mode block PAC, select the option DIGITAL INPUTS or DIGITAL OUTPUTS. The possible function assignments are offered.
- Activate functions:
Enter number of the desired input/output and confirm with ↵.
- Switch functions to inactive:
Enter the number 0 and confirm with ↵.

2. Technical data of the inputs and outputs

2.1 Circuit diagrams

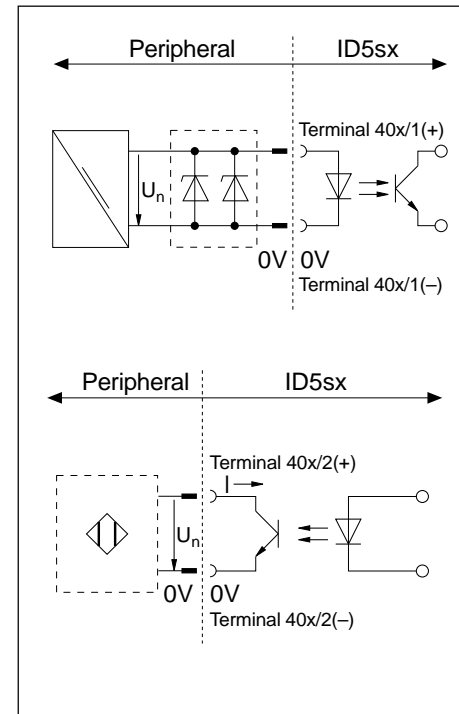

Intrinsically safe inputs

- Power supply externally with a power supply unit (nominal voltage $U_n = 12 \dots 24$ V DC) and via a Zener barrier.
- Safety separation by electrical isolation.
- U_{max} and I_{max} in accordance with MMRx terminal diagram in the "MMRx – ID5sx explosion-proof weighing system" guide for installers.

Intrinsically safe outputs

- Power supply externally via a Namur isolation switching amplifier following DIN 19234.
- Nominal voltage $U_n = 7 \dots 9$ V DC
- Switch-on point $I \geq 1.2 \dots 2.1$ mA
- Switch-off point $I < 1.2$ mA
- Safety separation by electrical isolation.
- Open collector.
- U_{max} and I_{max} in accordance with MMRx terminal diagram in the "MMRx – ID5sx explosion-proof weighing system" guide for installers.

2.2 Function assignments

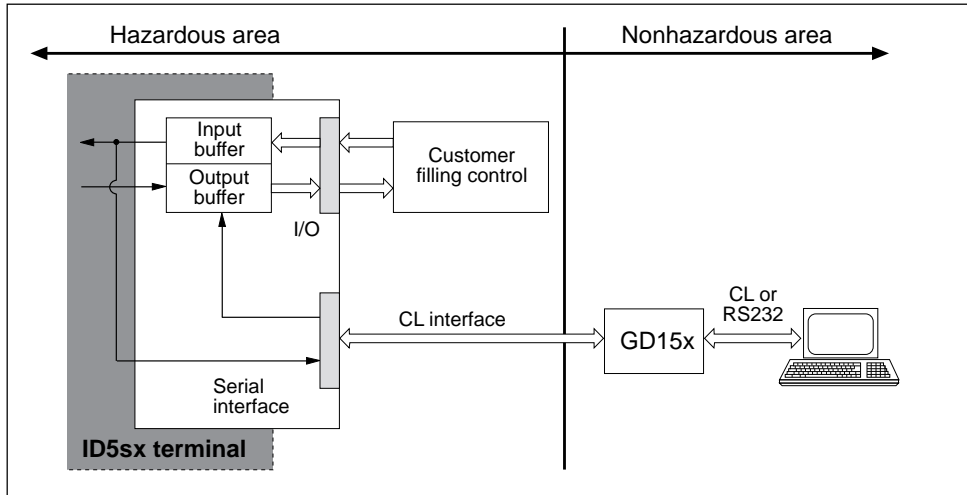

The inputs and outputs can be read or set via input and output buffers.

Application block No. for inputs: 207

Application block No. for outputs: 206

3. Inputs and outputs of the ID5sx/DosPac

With the Pac software ID5sx/DosPac, functions (signals) are already preassigned to the inputs and outputs; the software reads or sets inputs and outputs automatically. The following holds for the inputs and outputs:

- Function switched off = logic "0" = no power supplied
- Function switched on = logic "1" = power supplied

Caution

The functions are described in the ID/DosPac operating instructions and installation information. The function assignments described there do not apply to use with the ID5sx. They are described in the following table. The numbering of the inputs and outputs refers to the MMRx terminal diagram in the "MMRx – ID5sx explosion-proof weighing system" guide for installers.

Default assignment for ID5sx/DosPac

Input 1 (terminal 400/x)	START	Output 1 (terminal 403/x)	COARSE FEED
Input 2 (terminal 401/x)	STOP	Output 2 (terminal 404/x)	FINE FEED
Input 3 (terminal 402/x)	ACKNOWLEDGE	Output 3 (terminal 405/x)	READY
		Output 4 (terminal 406/x)	START
		Output 5 (terminal 407/x)	CORRECT
		Output 6 (terminal 408/x)	POOR

5. Master mode

5.1 General information

The interface parameters can be set in the master mode of the ID5sx. CL interface and RS232C interface at the same GD15x are always set to the same values. The interfaces of the second GD15x can be configured differently from the first. To select the desired interface, see sections 5.3.1 and 5.3.2.

Activating the master mode

See ID5 operating instructions.

5.2 Modes of the interface

Two modes are possible on the nonhazardous side of the GD15x:

- PRINT MODE: Formatting of weighing results and output on an external printer.
- DIALOG MODE: Data interchange with an EDP device. The EDP device controls the data interchange by control commands to the weighing terminal.

5.3 Configuring the interface

The following pages describe the changes to the description of the master mode for Option 089 which are necessary for the ID5sx.

Printout of the set configuration

It is not possible to print out the set configuration via the GD15x.

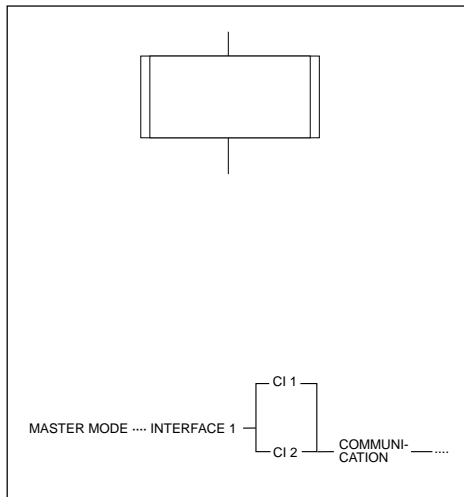

Representation

The master mode block INTERFACE 1 is divided into sub-blocks. Branches to a sub-block are represented as shown opposite. For better orientation, the sub-blocks are numbered.

Note on interface description Option 089

In the interface description for Option 089, an information line is always shown at the bottom. It contains all sub-blocks which you have selected with YES up to the sub-block shown.

In the ID5sx case, the sequence shown opposite applies to the first 3 steps.

1. Cautionary notes and organization of the documentation

Available interfaces

- The ID5sx weighing terminal has 3 digital inputs and 6 digital outputs.
- In addition, up to 2 GD15x interfaces can be attached. Each GD15x has either a CL interface (20 mA current loop) or an RS232C interface available for the attachment of peripheral units.
- The interface command set and syntax are compatible with those of Option 089.



Cautionary notes

Note the following in the interface description for Option 089 supplied:

- The information there in concerns the cables between the CL and RS232C interfaces of the GD15x interface and the external device! It does not apply to the cables between the GD15x interface and the weighing terminal!
- For connections to the ID5sx weighing terminal, the "MMRx – ID5sx explosion-proof weighing system" guide for installers applies. This particularly concerns the connection of the GD15x interfaces and the connections to the inputs and outputs.

Note the following with ID5sx/DosPac:

- As the ID5sx has only 3 inputs and 6 outputs, the assignment given in the operating instructions of the ID/DosPac does not apply. The assignment with the ID5sx/DosPac is described in section 3 of these instructions. For the assignment of the 3 inputs there are 6 possibilities available; for the assignment of the 6 outputs, 8 possibilities.

Documentation regarding the inputs and outputs

The documentation on the inputs and outputs can be found in these instructions.

Documentation regarding CL and RS232C interfaces

While the documentation on the CL and RS232C interfaces is essentially covered by the enclosed interface description for METTLER MultiRange Option 089, it is imperative to note the differences described in what follows:

- All references to other instructions do not apply. The only exception in the entire set of instructions: the reference on page 11 to the Technical Information Bulletin (TIB) "The METTLER CL interface". This reference continues to hold.
- Section 1 "Introduction"
 - In contrast to Option 089, only a CL or an RS232C interface of the GD15x can be used.
- Section 2 "Installation"
 - The entire section does not apply to the ID5sx.
 - For the data interface in the ID5sx no installation work must be performed.
 - Switching of the CL interface in the GD15x is described in section 2 of these instructions.
- Section 3 "Technical Data"
 - Note the green correction sheet for Option 089 on attachment of the CL interface.
 - Comply with the cautionary notes.
 - Section 3.5 "Transmit buffer".
Transmit buffers must be addressed as application blocks 103 (1st GD15x, CL1) or 104 (2nd GD15x, CL2). For the assignment 1st GD15x – 2nd GD15x, see terminal diagram in the MMRx – ID5sx guide for installers.
- Section 4 "Command set"
 - The command set has been extended by the commands for the inputs and outputs. They are described in section 4 of these instructions.
 - A printout on the GD46 printer is not possible as this can not be attached to the ID5sx.
 - In the case of print commands, the command set operates without any change to the code table ISO 646 - 1973 as an identification on the approved printer is not necessary.
 - Performance capability, command and response format of the print commands depend on the attached printer.
 - The command set has no special command for an audio signal.
- Section 5 "Master mode"
 - P. 57-61: The description is replaced by section 5 in these instructions. For the assignment 1st GD15x – 2nd GD15x, see terminal diagram in the MMRx – ID5sx guide for installers.
 - P. 62-80: Note reference to the information line at the start of section 5.3 of these instructions.

Notes

- In the case of wrong entries, the error message NOT ALLOWED appears. Repeat entry.
- Check all 6 or 8 possibilities to ensure no earlier assignments are stored. Double assignments for an input or output are possible.
- After quitting the master mode, the settings made are stored in a fail-safe manner.
- With RESET PAC the assignment of the digital inputs/outputs can be reset to the default setting.
- Some applications of the ID/DosPac require a second Option 084. This is not possible with the ID5sx. The master mode blocks concerned do not appear with the ID5sx/DosPac.

4. Commands for inputs and outputs in the command set

Reading inputs

Command

AR 207 C_R L_F

format

Action

After receipt of the "AR" command, the terminal sends the current input statuses, one EBx bit per input.

Response format

AB EB3 EB2 EB1 C_R L_F

Meaning

Logic "0" = no power supplied to input
Logic "1" = power supplied to input

Setting outputs

Command format

AW 206 AB6 AB5 AB4 AB3 AB2 AB1 C_R L_F

Meaning

Logic "0" = no power supplied to output
Logic "1" = power supplied to output

Action

After receipt of the "AW" command, the 6 outputs are set in accordance with the output bit ABx.

Response format

AB C_R L_F

or with a command which can not be executed (e.g. wrong application block No.):

ES C_R L_F

Operating instructions Interface description

METTLER TOLEDO

METTLER TOLEDO MultiRange ID5sx weighing terminal

Mettler-Toledo (Albstadt) GmbH, D-72458 Albstadt, Germany, Tel. (0 74 31) 14-0, Fax (0 74 31) 14-232

- A** Mettler-Toledo Ges.m.b.H., 1100 Wien, Tel. (01) 604 19 80, Fax (01) 604 28 80
 - AUS** Mettler-Toledo Ltd., Port Melbourne, Tel. (3) 9646 4551, Fax (3) 9645 3935
 - B** N.V. Mettler-Toledo S.A., 1651 Lot, Tél. (02) 3340211, Fax (02) 3781665
 - CH** Mettler-Toledo (Schweiz) AG, 8606 Greifensee, Tel. (01) 944 45 45, Fax (01) 944 45 10
 - CN** Mettler-Toledo (Shanghai) Ltd., Shanghai 200233, Tel. (21) 470 3932, Fax (21) 470 3351
 - D** Mettler-Toledo GmbH, 35353 Giessen 11, Tel. (0641) 507-0, Fax (0641) 5 29 51
 - DK** Mettler-Toledo A/S, 2100 Copenhagen Ø, Tel. (39) 29 04 00, Fax (39) 29 04 26
 - E** Mettler-Toledo S.A.E., 08038 Barcelona, Tel. (93) 223 22 22, Fax (93) 223 02 71
 - F** Mettler-Toledo s.a., 78220 Viroflay, Tél. (1) 30 97 17 17, Fax (1) 30 97 16 16
 - HK** Mettler-Toledo PacRim Ltd., Kowloon, Hongkong, Tel. 724 23 48, Fax 724 23 49
 - I** Mettler-Toledo S.p.A., 20026 Novate Milanese, Tel. (02) 33332.1, Fax (02) 35 62 973
 - J** Mettler-Toledo K.K., Takarazuka 665, Tel. 797 74 2406, Fax 797 74 2641
 - N** Mettler-Toledo A/S, 1008 Oslo 10, Tel. (22) 30 44 90, Fax (22) 32 70 02
 - NL** Mettler-Toledo B.V., 4000 HA Tiel, Tel. (03440) 11311*, Fax (03440) 20530
 - S** Mettler-Toledo AB, 120 08 Stockholm, Tel. (08) 702 50 00, Fax (08) 642 45 62
 - SGP** Mettler-Toledo (S.E.A.) Pte. Ltd., Singapore 139944, Tel. 0065 778 67 79, Fax 0065 778 66 39
 - TH** Mettler-Toledo (Thailand), Bangkok 10310, Tel. 719 64 80-87, Fax 719 64 79
 - UK** Mettler-Toledo Ltd., Leicester, LE4 1AW, Tel. (0116) 235 7070, Fax (0116) 236 6399
 - USA** Mettler-Toledo Inc., Worthington, Ohio 43085, Tel. (614) 438-4511, Fax (614) 438-4755
 - USA** Mettler-Toledo Inc., Hightstown, NJ 08520-0071, Tel. (609) 448-3000, Fax (609) 586-5451
- For all other countries: **Mettler-Toledo AG, VI**, 8606 Greifensee, Tel. 01/944 22 11, Fax 01/944 31 70

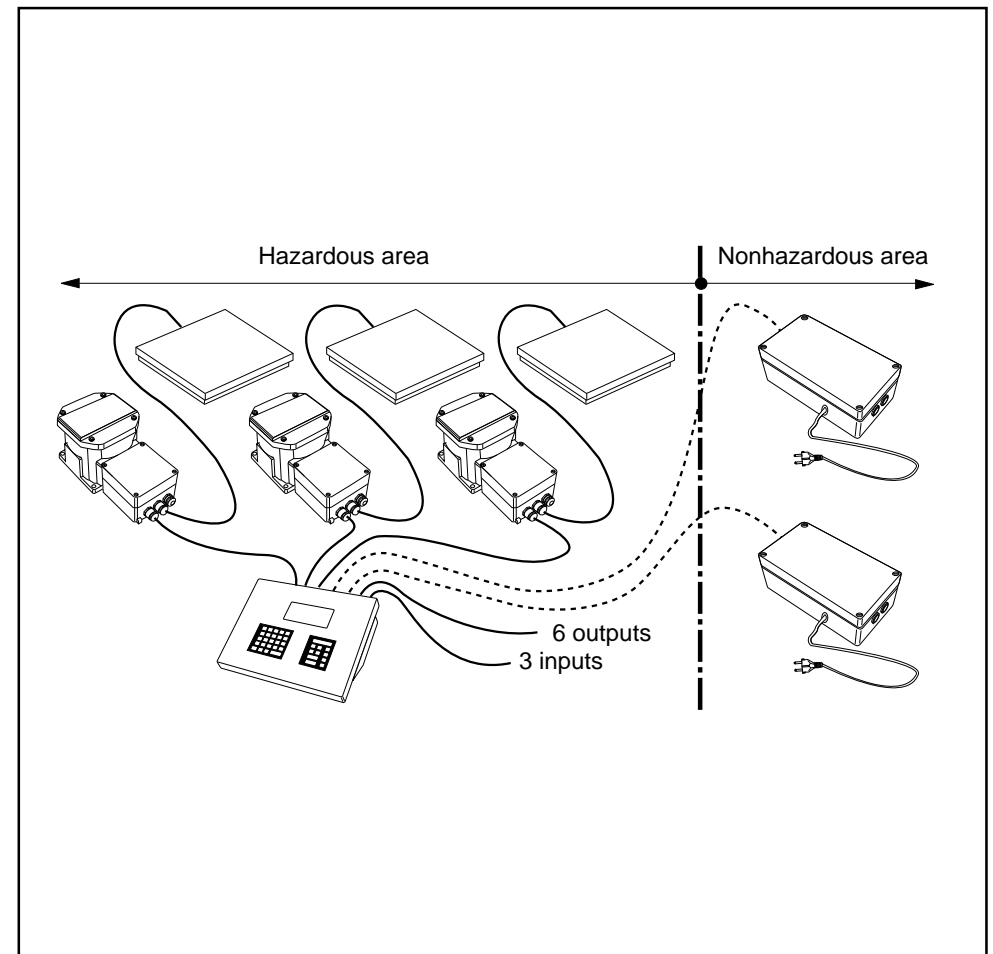

Contents

- 1. Cautionary notes and organization of the documentation 1**
- 2. Technical data of the inputs and outputs 3**
 - 2.1 Circuit diagrams 3
 - 2.2 Function assignments 4
- 3. Inputs and outputs of the ID5sx/DosPac 5**
- 4. Commands for inputs and outputs in the command set 7**
- 5. Master mode 8**
 - 5.1 General information 8
 - 5.2 Modes of the interface 8
 - 5.3 Configuring the interface 8

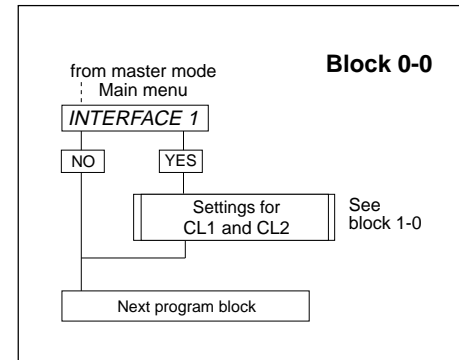

5.3.1 Selecting the interface
 For configuration of the CL1 and CL2 interfaces, select "INTERFACE 1".

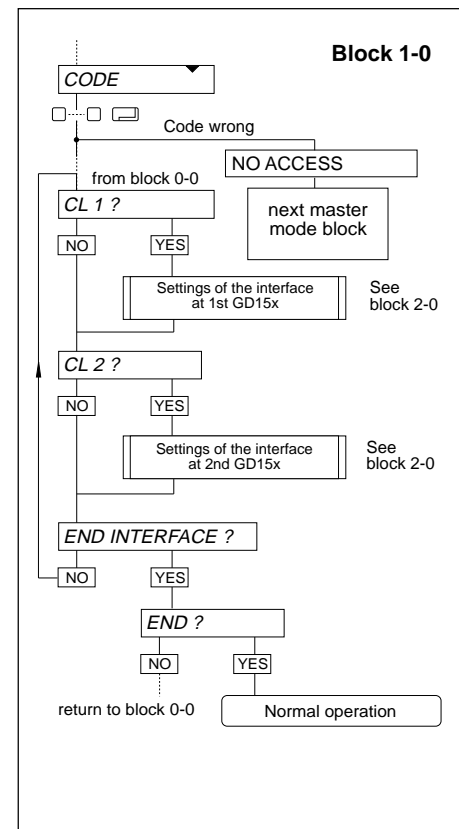

5.3.2 Selecting the GD15x
 Two GD15x interfaces can be connected to the ID5sx corresponding to "first" and "second" GD15x in the MMRx terminal diagram (see "MMRx – ID5sx explosion-proof weighing system" guide for installers). A selection is thus necessary.

Before selecting the GD15x, enter access authorization.

The following entries in this sub-block specify the GD15x at which the interfaces are configured.

- CL 1 selects the interfaces at the first GD15x (terminals 203/x and 204/x)
- CL 2 selects the interfaces at the second GD15x (terminals 205/x and 206/x)

Sections 5.3.3 ff. in the interface description of Option 089 are the same for both GD15x interfaces. There is no RS232 program block.

