

bPro Compact

bPro compact scales boast user-friendly ergonomics and unrivaled applications. Superior performance in a compact form that's easy to use! All the advantages of the bPro family of scales in a compact design.

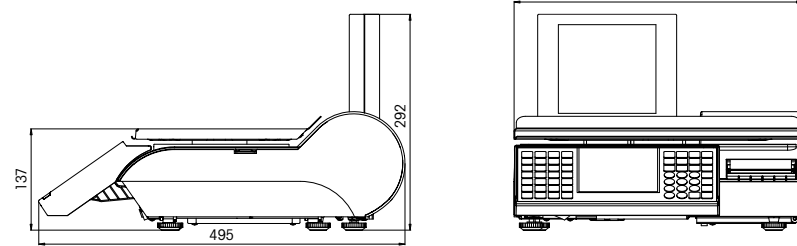

Dimensions bPro C2



Dimensions bPro U2

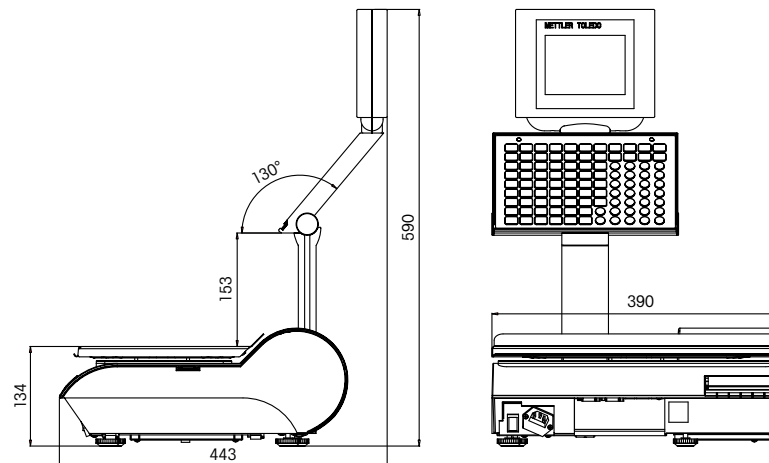

Retail Scales



bPro

- Rugged construction
- Excellent printing performance
- Network capability
- Exclusive design



Performance that Pays Off

Reliability you can Count On

Mettler-Toledo Ltd
LE4 1AW United Kingdom
Tel. (01)16 235 7070
Fax (01)16 236 6399
enquire.mtuk@mt.com

All other countries
Mettler-Toledo AG
Greifensee, Schweiz
Tel. +41-44-944 22 11
Fax +41-44-944 31 70

Subject to technical changes
©12/2006 Mettler-Toledo AG
Printed in Germany 72201911

www.mt.com

More information



Quality certification.
Development, production and auditing in accordance with ISO9001.



Environmental management system in accordance with ISO14001.



«Conformité Européenne».
This label is your guarantee that our products conform to the latest guidelines.

METTLER TOLEDO



bPro Shop Scales

for the price-conscious food trade

- **Rugged construction – unmatched reliability in everyday use**
- **Excellent throughput – high-quality label function**
- **Network capability – a pleasure to use**
- **Exclusive design – to complement the decor of your shop**

Unflagging performance day after day

Rugged yet easy to maintain. An extremely heavy-duty aluminium baseplate, high-grade polymer surfaces and sealed components offer superior protection for electronics and mechanics. Low weight makes everyday cleaning effortless.

Reduce your maintenance costs with scale construction aligned to reliability in everyday use.

Fast communication

High-speed processor performance and 4 MB memory support the fastest possible communication. Ethernet connection, two RS232 interfaces and RJ11 interface support the trouble-free connection of a number of external devices.

Top-quality printing performance

Two independent printer motors, up to 110mm/sec printing speed, over 90% metal parts, and easy maintenance are the hallmarks of a printer designed for high performance. Labels** and receipt printout, set benchmarks for design, quality and speed.

Exclusive design

Contemporary and practical. With its unique design, the bPro series of scales complements the décor of your shop. Rounded edges promote exceptional device hygiene. The 94 x 94mm screen displays operator and customer information in high contrast.

Efficient operating processes

Advanced scales with printing capability. bPro counter scales assist the operator by allowing them to concentrate completely on the customer. A reliable printer, intuitive software and fast communication within a network of up to 10 scales** helps you focus on your customers and your bottom line.



Fast information

bPro scales with backlit LCD shows information quickly and ultra sharp in any environment.

Direct keypad

bPro scales are equipped with highly sensitive membrane keypads for superior operating comfort. The METTLER TOLEDO "Light Touch" keypad, available as an option, sets the highest standards for washable keypad overlays for exceptional device hygiene.



Individual design

Design your counter scale to match the décor of your shop.

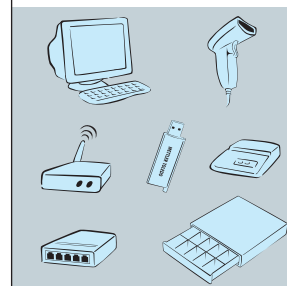

Communication

Easily integrate your external devices via RJ11, RJ45 and two RS232 interfaces.



Labels** and receipt printout

Easy-to-change rolls and countless label design options; product traceability.

Technical Data

bPro U2 / bPro C2 Shop Scale

Weighing range	3 kg/6 kg	6 kg/15 kg	30 kg
Graduation	1/2 g	2/5 g	5 g
Minimum capacity*	20 g	40 g	100 g

* EC: Printing is possible with a minimum load, but not with price marking.

Performance features

Display

High-resolution backlit LCD
5-digit weight display
5-digit tare display
7-digit unit price
7-digit total price
16-alphanumeric-character display

Functions

Manual control function, prepackaging, cash function**, inventory function, bulk sales, self-service and training function, manual control function with sales receipt, label and total label, self-adhesive total receipts

Keypad

Membrane
bPro U2: 99 keys, 30 function keys, 69 freely programmable fixed keys
bPro C2: 58 keys, 28 function keys, 28 freely programmable fixed keys
Option bPro C2/ bPro U2: "Light Touch" keypad for the highest standards.
Washable keypad overlays for superior device hygiene.

Printer

2" print head for sales receipt/labels**. Thermal printer up to 110 mm/sec, logo printing on sales receipt and label, 20 freely definable labels, 20 pre-defined labels

Interfaces

RJ45, Ethernet TCP/IP
2 serial interfaces
RJ11 connection for cash register drawers
Wireless option:
WLAN IEEE802.11b/g*

Memory

4 MB application memory meets the highest standards for speed
1 MB data memory

Security

Password login by employees
Electronic journal
Price changes and sales reports protected by pin codes

Reports

Customisable daily reports
Reporting at two turnover stages
Electronic sales journal
Reports per employee, department, category, article, price changes (incl. date & time) and for specifically defined time periods.

* Available as an option – (wireless card, colored stand and "Light Touch" keypad not factory installed)

** Available as an option – can be activated with a license.