

Specifications



| Model | BBA429 | BBA439check | BBA449check+ | IND429 | IND439check | IND449check+ |
|--|------------------------|-------------|--------------|--------------------------|-------------|--------------|
| Type of construction | Compact balance | | | Weighing terminal | | |
| Basic functions | | | | | | |
| Zero setting | • | • | • | • | • | • |
| Taring | • | • | • | • | • | • |
| Change of unit | • | • | • | • | • | • |
| Printing/data transfer | • | • | • | • | • | • |
| MinWeigh | • | • | • | • | • | • |
| Counting | – | – | • | – | – | • |
| Info | – | – | • | – | – | • |
| Identification (2 values) | – | – | • | – | – | • |
| Date/time | – | – | • | – | – | • |
| Tare definition | – | – | • | – | – | • |
| Checkweighing | | | | | | |
| Numeric display | • | • | • | • | • | • |
| ± application (check, check+) | – | • | • | – | • | • |
| Bargraph ± display | – | • | • | – | • | • |
| Colored ± display | – | • | • | – | • | • |
| Input modes for target weights | – | 3 | 3 | – | 3 | 3 |
| Input modes for target quantities | – | – | 2 | – | – | 2 |
| Classify | – | – | • | – | – | • |
| Standard tolerances | – | • | • | – | • | • |
| «Take-away» mode | – | – | • | – | – | • |
| Memory for ± data records | – | 99 | 99 | – | 99 | 99 |
| Memory for classification parameters | – | – | 99 | – | – | 99 |
| Miscellaneous | | | | | | |
| Balance connections | – | – | – | 1 | 1 | 1 |
| Number of keys | 6 | 10 | 25 | 6 | 10 | 25 |
| Battery operation (optional) | • | • | • | • | • | • |
| IP69k protection | • | • | • | • | • | • |
| Version with analog balance interface | – | – | – | • | • | • |
| Version with IDNet balance interface | – | – | – | • | • | • |
| Version for Zone 2/22 hazardous areas (Category 3) | – | – | – | • | • | • |

BBA4x9 models

(Certifiable resolution, multirange balance)

| Weighing range | Size of weighing platform | |
|----------------|---------------------------|--------------|
| | 240 x 300 mm | 300 x 400 mm |
| 3 kg | 0.5g/1g | – |
| 6 kg | 1 g/2 g | – |
| 15 kg | 2 g/5 g | – |
| 30 kg | – | 5 g/10 g |

Options

Interfaces

The instruments are fitted with one RS232 interface as standard. In addition, one of the following options is available:

- Second RS232 interface
- RS422/RS485 interface
- Ethernet interface
- Wireless LAN interface
- USB (slave) interface
- Digital I/O (with 4 inputs and 4 outputs)

Further options

- Internal storage battery (including AC charging adapter)
- Version for external 12 to 24 VDC power supply

Options that cannot be used in hazardous areas

- External storage battery for model BBA4x9 (including AC charging adapter)

Dimensions

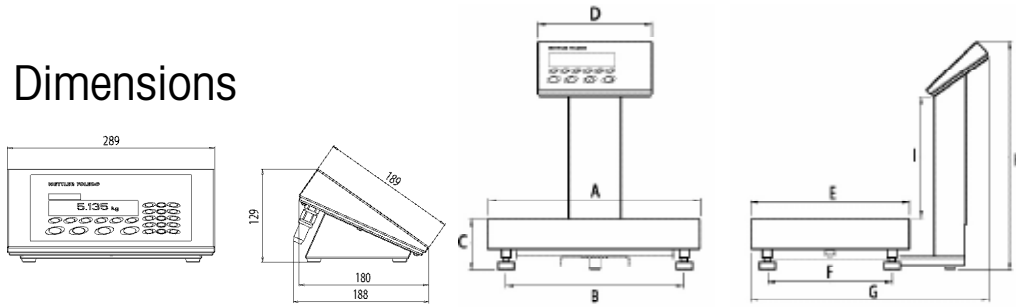

BBA4x9check

| Model | A | B | C | D | E | F | G | H | I |
|-----------|-----|-----|-------|-----|-----|-----|-----|-----|-----|
| A | 300 | 235 | 102,5 | 216 | 240 | 175 | 380 | 432 | 228 |
| BB | 400 | 335 | 104,5 | 216 | 300 | 235 | 450 | 432 | 230 |

Accessories

| | |
|---|-------------|
| GA46 thermal printer, stainless steel housing, RS232 interface, incl. 2.5 m cable | 00505471 *1 |
| GA46 thermal printer, stainless steel housing, RS232 interface, incl. 0.4 m cable | 00507229 *1 |
| GA46 W thermal printer, stainless steel housing, RS232 interface, IP65, protective cover, take-up device, incl. 2.5 m cable | 00505799 *1 |
| GA46 W thermal printer, stainless steel housing, RS232 interface, IP65, protective cover, take-up device, incl. 0.4 m cable | 00507230 *1 |
| RS232 cable for PC (3 m, 8 pin <-> 9 pin Sub D socket) | 00504376 *2 |
| RS232 male connector, 8 pin | 00503756 *2 |
| RS422/RS485 cable (3 m, 6 pin <-> open ends) | 00204933 *2 |
| RS485 male connector, 6 pin | 00204866 *2 |
| Ethernet 10/100 Base T twisted pair cable (5 m -> 8 pin RJ45) | 00205247 *2 |
| Ethernet 10/100 Base T twisted pair cable (20 m -> 8 pin RJ45) | 00208152 *2 |
| USB adapter cable (0.2 m -> USB series A socket) | 22006268 *2 |
| USB adapter cable (3 m -> USB series A socket) | 22007713 *2 |
| Relay box for digital I/O option (same as for IND690) | 22011967 *1 |
| Cable between digital I/O option (same as for IND690) | 00504458 *2 |
| Digital I/O male connector, 19 pin | 00504461 *2 |
| Protective cover for BBA4x9 instruments (set of 3 covers) | 22013992 *1 |
| Protective cover for IND4x9 terminals (set of 3 covers) | 22013963 *1 |
| Stand, stainless steel, for IND4x9, height 330 mm | 22013964 |
| Stand, stainless steel, for IND4x9, height 660 mm | 22013965 |
| Stand, stainless steel, for IND4x9 and KA-, KB-, MA-, MB- and DB- weighing platforms, height 330 mm | 22014836 |
| Bench support, stainless steel, for IND4x9, suitable for bench stand 00503632 and 00504854, height 500 mm | 22014835 |
| Floor stand, stainless steel, for IND4x9, height 1000 mm | 22014834 |
| ADI419 secondary display (IP69k, RS232, 3m cable incl., display without backlighting) | 22013962 *1 |
| ADI419-B secondary display (IP69k, RS232, 3m cable incl., display with backlighting) | 22014022 *1 |
| Stand base for floor stand | 22011982 |
| Wall adapter, stainless steel, for IND4x9, filling | 22013966 |
| Wall bracket, stainless steel, for IND4x9, filling and rotating | 22014833 |
| GA46 mounting adapter, stainless steel, for bench and floor stand and wall bracket | 22011985 *1 |
| External storage battery (additional storage battery for BBA4x9, excluding charger) | 22013988 *1 |
| Charger for external and internal storage battery | 22014056 *1 |

The following statements apply to installations in hazardous areas:

*1 This instrument/accessory must not be used in hazardous areas!

*2 This accessory is suitable for connecting a terminal in a hazardous area to an instrument in a non-hazardous area.

Sales and service:

www.mt.com

For more information

ServiceXXL
Reliable Service



Service XXL

- Integral service plan
- Custom-designed service packets
- Service contracts
- On-site calibration certificates
- Minimum weight determination with MinWeigh

Quality certificate.

Development, production and testing to ISO 9001. Environmental management system to ISO 14001.

«Conformité Européenne».

This mark means you can rest assured that our products meet the requirements of the latest EU guidelines.

Checkweighers

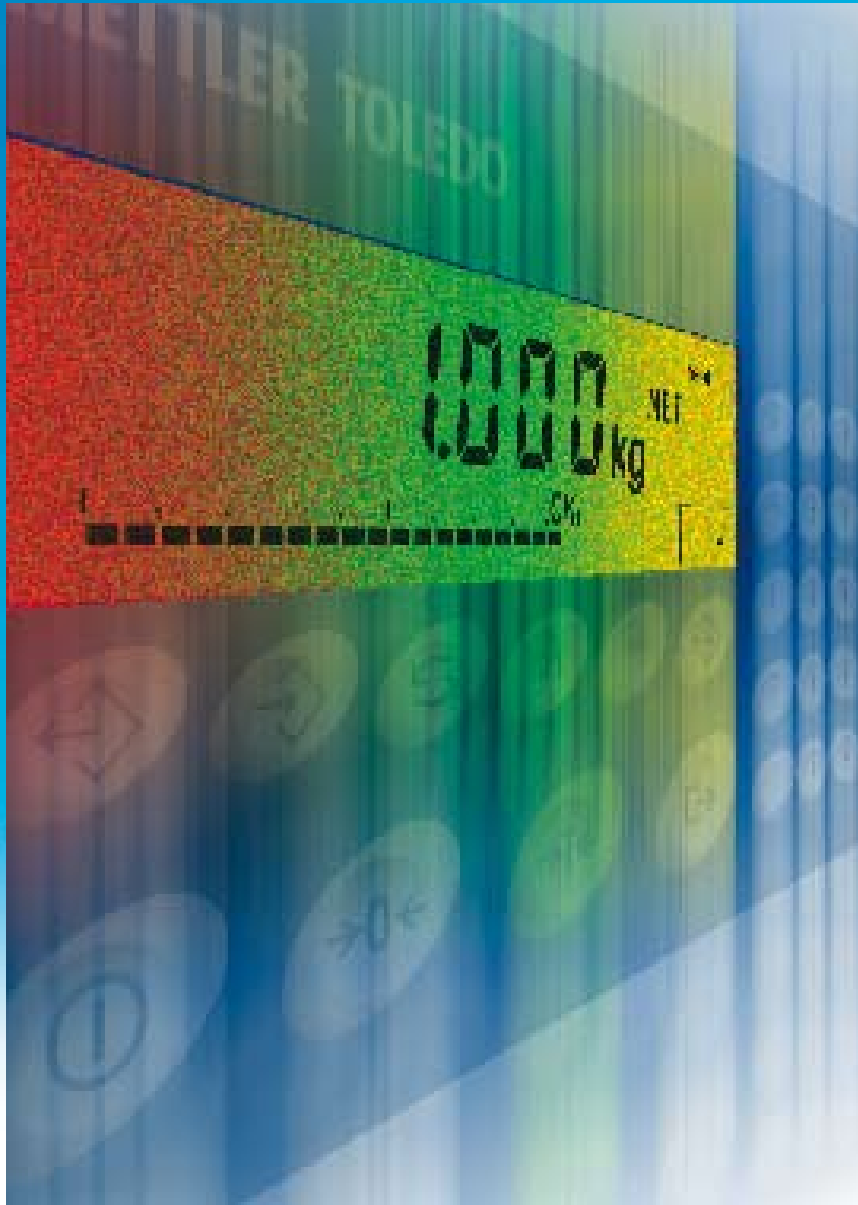

**The optimal solution for
manual checkweighing:**

4 Series with check application

- Hygienic design
- Colored backlighting
- Fast and precise
- Flexibly adjustable

IP69k
GMP
EHEDG
NSF

Colored tolerance control
for unmistakable results!

METTLER TOLEDO

The perfect solution for convenient checkweighing

Hygienic design, fast processing of measurement values, and the innovative color display set new standards in the industry

GMP

Good Manufacturing Practice

"Very good for working to GMP!". That's how the IND4x9 terminals and BBA4x9 compact balances were rated by the Steinbeis Transfer Institute of Berlin University. The evaluation included cleanability, calibration, surfaces, and the qualification documentation.



IP protection

With IP69k protection according to DIN 40050, the balances withstand even the harshest environments.

The instruments are dustproof and also suitable for cleaning with high-pressure equipment.

Display

Color backlit 7-digit 7-segment LC display. Brightness and colors individually adjustable.

Wireless LAN

Communication without cables! The IND4x9 terminals and BBA4x9 compact balances are optionally available with a WLAN interface according to IEEE 802.11b. The instruments can therefore be integrated into a WLAN network without problem. Data security is assured by WEP and WPA encryption. The WLAN module is conveniently configured with a WEB browser.

IND4x9 weighing technology

The complete range of METTLER TOLEDO weighing platforms can be connected to the IND4x9 terminals. Terminal variants with analog and digital (IDNet) balance interfaces are optionally available. Most analog balances from other manufacturers can also be used. You will find the metrological data in the operating instructions or the data letter of the terminal.

Interfaces

A number of different interfaces are available for computer and printer connections (see options). The protected interfaces are installed on the back of the instrument where they are easily accessible via IP69k protected sockets.



Intrinsic safety

All IND4x9 terminals are available in an intrinsically safe version for hazardous areas. As non-sparking equipment they fulfill the requirements of Category 3 and can therefore be used in Zones 2 (Gas) and 22 (Dust).

A comprehensive range of weighing platforms for hazardous areas is available.



Model BBA4x9



Hygienic design without compromise

Hygiene

The IND4x9 weighing terminals and BBA4x9 compact balances were specially designed for use in hygienically sensitive areas.

The smooth surfaces and the materials used allow easy and thorough cleaning. Even the back of the instrument has an impressively smooth, closed surface. The National Sanitation Foundation (NSF) and European Hygienic Engineering and Design Group (EHEDG) have performed a positive evaluation of the instruments. Corresponding certificates and reports are available at www.mt.com.

EHEDG



Mobility

As an option, the instruments can also be supplied with a built-in storage battery. A charge status indicator warns you in good time when the battery needs recharging. A single charge of the battery allows between 9 and 90 hours of network-independent operation.

9 h: continuous operation
90 h: 10% operating time, power-off mode switched on

For the instruments of the BBA4x9 series a version with external storage battery is available. It is advisable to use a second storage battery. While the first battery is working, the other can be recharged.



BBA4x9 weighing technology

The instruments of the BBA4x9 series used a hermetically encapsulated stainless steel strain gauge weighing cell. The compact design is available with weighing ranges from 3 to 30 kg. The following platform sizes are available:

240x300 mm and 300x400 mm.
For non-certifiable use, up to 30,000 points can be displayed. For certifiable applications, a resolution of up to 2 x 3000e (multirange) is possible.

Checkweighing

The optimal solution for manual checkweighing is provided with the "check" and "check+" software modules. Flexible setting possibilities in the Setup menu allow the instruments to be adapted to different processes. The intuitive operation reduces the training effort and helps avoid incorrect inputs!



colorWeight® provides clarity

Colored display for unmistakable results



The colored backlighting of the LC display provides easily readable unmistakable information as to whether or not the weight is within the tolerance limits! If you don't like our choice of colors, you can mix other colors in the Setup menu. The display brightness is also adjustable. The bargraph provides additional information about the distance from the target weight.

Yellow

Weight above the tolerance

Green

Weight within the tolerance

Red

Weight below the tolerance

Dimmed

Checkweighing not activated or net < = 0

Flexible processes for convenient working

The "check" and "check+" software modules are specially designed for manual checkweighing. The "check+" software module also allows manual checkweighing as well as classification into up to 5 classes. Numerous setting possibilities in the Setup menu make adaptation to individual requirements child's play:

- 3 different possibilities for inputting the target weight and tolerances
 - Absolute:** Definition of the lower and upper weight or quantity limits
 - Relative:** Definition of target weight or target quantity, + and – tolerances as weight values or quantities
 - Percent:** Definition of target weight, + and – tolerances in percent

- Target values can be input using the keyboard or weighed
- Different sizes of + and – tolerance can be used
- When standard tolerances are used, only the target value is input or weighed. The effort is minimal and incorrect inputs are impossible.
- Memory for 99 different articles and tolerances. Easy to call up and identify! The display shows the number of the article memory at bottom right.
- Secured against unauthorized changes! Individual functions, such as inputting and saving target values, can be disabled for the user.
- What do you prefer to see? The current weight, quantities or the deviation from the target weight? No problem! One simple input in the Setup menu is enough.
- The "Take away" function allows repeated removal of a defined weight or quantity with automatic tolerance checking and automatic taring. The "Classify" function allows articles to be classified into up to five different classes.