

CSN840 Pallet™

Optimizing the pallet handling



Wide measuring capabilities

for handling a large range of goods from small to big pallets, as well as dark and glossy wrapping with the highest accuracy. Irregularities such as protrusions sticking out will also be included in the dimensions, securing a correct data foundation.



Seamless integration

to any location and traffic on the floor. Ceiling, floor or wall-mounting possibilities, enables the user to find a suitable location that optimizes the pallet throughput and does not interfere with current operations. Pallets can be transported and placed underneath the dimensioner from any direction.



All pallet data including

dimensions, weight and identification automatically collected and processed to host in one single string. The system is modular and allows for different configurations for meeting the customer's needs. User can choose the components and software modules that suit their application.



Easy to operate

with a user-friendly work-station. The data collection is initiated by scanning the barcode. The data is instantly displayed on the monitor and a traffic light shows the status of the measuring process. The operator has full control at all times, also of historical data on the screen.



Service website

for each unit making installation, maintenance and upgrades quick and easy through Internet, both remote and onsite. A user-friendly interface guides the user through the different commands of the system, making any adjustments simple, reducing the need for advanced training and maximizing system capabilities and up-time.



CSN840 Pallet™

Static package solution

The CSN840 Pallet™ is a complete data capture unit that automatically collects dimensions, weight and identification on a wide variety of pallets. The CSN840 Pallet™ is ideal for improving pallet processes in goods terminals, pallet drop-off centers, as well as shipping docks and warehouses. The standard solution has the capacity to dimension approximately 200 pallets per hour. Throughput can be increased through optimized traffic on the floor. The overhead dimensioning scanners can be floor, wall or ceiling-mounted.

The CSN840 Pallet™ guarantees full data integrity with the well proven laser range finder technology and is approved according to industry standards.

Technical data

CSN840 Pallet™

Static pallet solution

Features and Benefits

- Laser range finder technology for accurate measuring of length, width, height
- Wireless long-range hand held barcode scanner for automatic ID
- 20 mm (0.75 in) accuracy for reliable measurements
- Ceiling, floor and wall-mounting options for seamless integration to customers site requirements
- Merging software for secure collection and linking of pallet data
- Host communication for seamless transfer of data to customer host
- Barcode validation for customization of barcodes to accept or reject
- Alibi memory for tamper-proof storage of data
- Website with graphical menu for quick set up, easy configuration, monitoring and access to statistics
- Application software embedded in dimensioner for "all in one box" - no extra PC required, compact and cost effective
- Remote diagnostics for easy upgrades and service, maximizing up-time
- DimCentral™ monitoring for immediate fault reporting and performance surveillance
- Graphical colour user-interface and 12" or 17" TFT-LCD monitor for clear overview of measuring process
- Traffic light to guide operator
- CS2200LX display for legal for trade applications

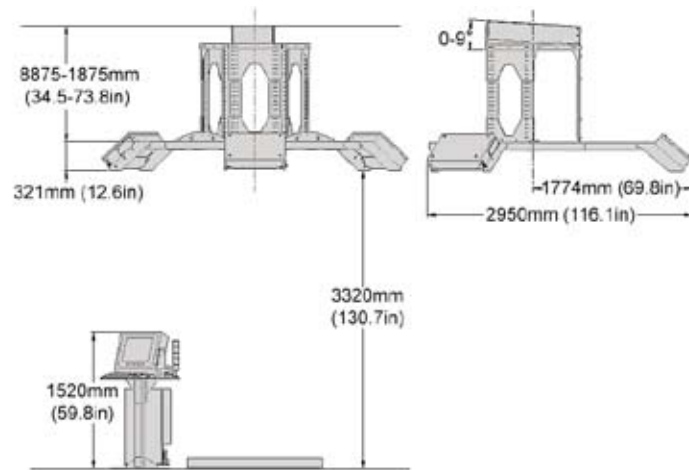

Specifications

Dimensioning accuracy	± 20 mm (± 0.75 in.)
Maximum size (LxWxH)	1830 x 1830 x 2600 mm (72 x 72 x 102 in.)
Minimum size (LxWxH)	200 x 200 x 200 mm (8 x 8 x 8 in.) 1)
Weight accuracy	± 0.5 kg (± 1 lb.) or ± 1.0 kg (± 2 lb.) or ± 2.0 kg (± 4 lb.)
Maximum weight	1500 kg (3250 lb) or 3000 kg (6500 lb) or 6000 kg (13,000 lb)
Minimum weight	Dependent on type of METTLER TOLEDO scale
Throughput	Around 200 pallets per hour depending on how pallets are handled in the terminal
Shape	All solid shapes 2)
Surface characteristics	Most surfaces. Variance are sometimes encountered when surface is transparent/translucent or very glossy 3)
Orientation	Place most stable surface down within the defined field of view
Background	Flat continuous surface. Instrument verifies acceptable background.
Spacing	Objects placed under the dimensioner individually
Operational temperature	0° to 40 °C (14° to 104 °F)
Power	230 V 50 Hz, or 100-115 V 60 Hz
Laser type	Class 2
Interface	General Ethernet (TCP/IP) or Standard host (RS232)
I/O ports	VGA, USB, keyboard, binary in, binary out

- 1) 100 x 100 x 100 mm (4 x 4 x 4 in.) in non-legal for trade applications
 2) Protrusions <7.5 cm (3in.) may be ignored and not included in the dimensions
 3) System gives message code if surface looks uncertain

Main Components

Dimensioner	CSN840.3
Scale - standard	IND425- Vertex 2158 for 6000 kg (13000lb) or 3000 kg (6500lb)
- option	IND425-ES3000/A for 3000 kg or IND425-ES1500/A (3250 lb)
Bar code reader	Datalogic Gryphon M130/D LR 433 MHz – long range Europe, 910 MHz US
Accessories	Colour TFT-LCD 12" or 17" monitor, standard USB keyboard, workstation, power management kit, traffic light and various stands
Application software	host communication, bar code validation, alibi memory, remote diagnostics

All hardware and software components are optional and can be purchased separately or as a complete data capture solution.



National Approvals
 Compliant health and safety regulation
 Internet: www.mt.com/dimensioning
 Worldwide service
 Tel. (866) 339-3538
 Email: dim@mt.com

Specifications subject to change without notice
 METTLER TOLEDO® is a registered trademark of Mettler-Toledo, Inc.
 Printed in USA.
 SAC-0307-LIT

www.mt.com/dimensioning

For more information