

# Measuring Module M 700<sup>®</sup> pH 2700(X)

---

For Simultaneous Measurement of  
pH Values, ORP, and Temperature



**METTLER TOLEDO**



74760

## Warranty

Defects occurring within 1 year from delivery date shall be remedied free of charge at our plant (carriage and insurance paid by sender). Sensors, fittings, and accessories: 1 year.

©2007 Subject to change without notice

## Return of Products Under Warranty

Please contact our Service Team before returning a defective device. Ship the cleaned device to the address you have been given. If the device has been in contact with process fluids, it must be decontaminated/disinfected before shipment. In that case, please attach a corresponding certificate, for the health and safety of our service personnel.

## Disposal

Please observe the applicable local or national regulations concerning the disposal of "waste electrical and electronic equipment".

---

## Trademarks

The following registered trademarks are used in this instruction manual without further marking

SMARTMEDIA®

is a registered trademark of Toshiba Corp., Japan

FOUNDATION FIELDBUS™

is a trademark of Fieldbus Foundation, Austin, USA

---

Mettler-Toledo AG,  
Process Analytics, Industrie Nord, CH-8902 Urdorf,  
Tel. +41 (44) 729 62 11 Fax +41 (44) 729 26 36  
Subject to technical changes.



## Mettler-Toledo GmbH

Process Analytics

Adresse Im Hackacker 15 (Industrie Nord), CH-8902 Urdorf, Schweiz  
Briefadresse Postfach, CH-8902 Urdorf  
Telefon 01-736 22 11  
Telefax 01-736 26 36  
Internet www.mt.com  
Bank Credit Suisse First Boston, Zürich (Acc. 0835-370501-21-90)

# Declaration of conformity Konformitätserklärung Déclaration de conformité



We/Wir/Nous

Mettler-Toledo GmbH, Process Analytics  
Im Hackacker 15  
8902 Urdorf  
Switzerland

declare under our sole responsibility that the product,  
erklären in alleiniger Verantwortung, dass dieses Produkt,  
déclarons sous notre seule responsabilité que le produit,

Description

Beschreibung/Description

pH 2700

to which this declaration relates is in conformity with the following standard(s) or other normative document(s).

auf welches sich diese Erklärung bezieht, mit der/den folgenden Norm(en) oder Richtlinie(n) übereinstimmt.

auquel se réfère cette déclaration est conforme à la (aux) norme(s) ou au(x) document(s) normatif(s).

EMC Directive/EMV-  
Richtlinie  
Directive concernant la  
CEM

89/336/EWG

Norm/Standard/Standard

EN 61326  
EN 61326 / A1

/ VDE 0843 Teil 20: 1998-01  
/ VDE 0843 Teil 20 / A1: 1999-05

Place and Date of issue  
Ausstellungsort / - Datum  
Lieu et date d'émission

Urdorf, August 28, 2003

Mettler-Toledo GmbH, Process Analytics

Waldemar Rauch  
General Manager PO Urdorf

Christian Zwicky  
Head of Marketing

**METTLER TOLEDO**

ArtikelNr.: 52960330KE

52960330KE-pH2700-in ternet.doc

## Declaration of conformity Konformitätserklärung Déclaration de conformité

**We/Wir/Nous****Mettler-Toledo GmbH, Process Analytics**

Im Hackacker 15  
8902 Urdorf  
Switzerland

declare under our sole responsibility that the product,  
erklären in alleiniger Verantwortung, dass dieses Produkt,  
déclarons sous notre seule responsabilité que le produit,

**Description****Beschreibung/Description****pH 2700X**

to which this declaration relates is in conformity with the following standard(s) or other normative document(s).

auf welches sich diese Erklärung bezieht, mit der/den folgenden Norm(en) oder Richtlinie(n) übereinstimmt.

auquel se réfère cette déclaration est conforme à la (aux) norme(s) ou au(x) document(s) normatif(s).

**Explosion protection  
Explosionsschutzrichtlinie  
Prof. contre les explosions**

**94/9/EG  
KEMA 04 ATEX 2056  
NL-6812 AR Arnhem, KEMA 0344**

**Low-voltage directive  
Niederspannungs-Richtlinie  
Directive basse tension**

**73/23/EWG**

**EMC Directive  
EMV-Richtlinie  
Directive concernant la CEM**

**89/336/EWG**

**Place and Date of issue  
Ausstellungsort / - Datum  
Lieu et date d'émission**

**Urdorf, July 16, 2004**

Mettler-Toledo GmbH, Process Analytics

Waldemar Rauch  
General Manager Ingold

Christian Zwicky  
Head of Marketing

**METTLER TOLEDO**

## Mettler-Toledo GmbH

Process Analytics

Adresse	Im Hackacker 15 (Industrie Nord), CH-8902 Urdorf, Schweiz
Briefadresse	Postfach, CH-8902 Urdorf
Telefon	01-736 22 11
Telefax	01-736 26 36
Internet	www.mt.com
Bank	Credit Suisse First Boston, Zürich (Acc. 0835-370501-21-90)

<u>Norm/Standard/Standard</u>	<b>94/9/EG:</b>	<b>EN 50014</b> <b>EN 50020</b> <b>EN 50281-1-1</b> <b>EN 50284</b>	
	<b>73/23/EWG:</b>	<b>DIN EN 61010-1 / VDE 0411 Teil 1:</b>	<b>2002-08</b>
	<b>89/336/EWG:</b>	<b>DIN EN 61326 / VDE 0843 Teil 20:</b>	<b>2002-03</b>

**METTLER TOLEDO**

KE pH 2700X-b.doc

# Contents

---

M700 pH 2700(X)

Warranty .....	2
Disposal .....	2
Trademarks .....	2
EC Declaration of Conformity .....	3
Intended Use .....	10
Conformity with FDA 21 CFR Part 11 .....	10
Safety Information .....	11
Application in Hazardous Locations: pH 2700X Module .....	11
Software Version .....	12
Modular Concept .....	13
<b>Short Description .....</b>	<b>14</b>
Short Description: FRONT Module .....	14
Short Description: Menu Structure .....	15
Short Description: BASE Module .....	17
<b>Terminal Plate pH 2700(X) Module .....</b>	<b>19</b>
Attaching the Terminal Plates .....	19
<b>Inserting the Module .....</b>	<b>20</b>
<b>Wiring Examples .....</b>	<b>21</b>
<b>Menu Selection .....</b>	<b>26</b>
<b>Menu Structure .....</b>	<b>26</b>
<b>Passcode Entry .....</b>	<b>27</b>
Changing a Passcode .....	27
Passcode Lost .....	27
<b>Configuring the Measurement Display .....</b>	<b>28</b>
<b>Calibration / Adjustment .....</b>	<b>30</b>
Adjustment .....	31
Calibration Methods .....	32
One-Point Calibration .....	32
Two-Point Calibration .....	32
Three-Point Calibration .....	32
Sensor Replacement (First Calibration) .....	32
Temperature Compensation .....	33
Temperature Compensation During Calibration .....	33
Automatic Temperature Compensation .....	33
Manual Temperature Compensation .....	33

# Contents

---

M700 pH 2700(X)

Selecting a Calibration Method.....	34
Calimatic Automatic Buffer Recognition .....	36
Calibration with Manual Entry of Buffer Values.....	38
Product Calibration .....	40
Calibration by Entering Data from Premeasured Electrodes .....	42
ORP Calibration/Adjustment .....	44
ISFET Zero Adjustment .....	46
<b>Parameter Setting: Operating Levels.....</b>	<b>48</b>
Administrator Level.....	48
Operator Level.....	48
Viewing Level .....	48
Parameter Setting: Lock Functions .....	49
Activating Parameter Setting.....	50
Documenting Parameter Setting .....	51
Settings of Sensor Data .....	53
Sensoface .....	55
Sensocheck.....	55
Sensoface Criteria.....	56
Parameter Setting: Cal Preset Values.....	57
Cal Preset Values .....	57
Tolerance Adjustment .....	57
Calimatic Buffer.....	59
Calibration Timer.....	60
Cal Tolerance Band .....	60
Parameter Setting .....	62
TC Process Medium .....	62
<b>Temperature Compensation of Process Medium .....</b>	<b>63</b>
ORP/rH Value .....	64
Delta Function .....	64
<b>Calculation Blocks.....</b>	<b>65</b>
Logbook .....	68
Factory Setting.....	68
Messages: Default settings and selection range .....	69
<b>Device Limits.....</b>	<b>69</b>
Configuring a Current Output .....	71
Current Outputs: Characteristics .....	72

# Contents

---

M700 pH 2700(X)

Output Filter .....	74
NAMUR Signals: Current Outputs .....	75
NAMUR Signals: Relay Contacts .....	76
Relay Contacts: Protective Wiring .....	77
Relay Contacts .....	78
Relay Contacts, Usage .....	78
Rinse Contact .....	79
Configuring the Rinse Contact .....	79
Icons in the Measurement Display .....	80
Limit Value, Hysteresis, Contact Type .....	80
OK1, OK2 Inputs: Specify Level .....	81
Switching Parameter Sets via OK2 .....	82
Selecting Parameter Set (A, B) via OK2 Input .....	82
Signaling Active Parameter Set via Relay Contact .....	82
<b>Maintenance.....</b>	<b>83</b>
Sensor Monitor .....	83
Temp Probe Adjustment.....	83
<b>Diagnostics Functions .....</b>	<b>84</b>
Device Description .....	84
FRONT Module .....	84
BASE Module.....	84
Module Diagnostics .....	85
Sensor Monitor .....	85
ServiceScope.....	85
Message Lst.....	86
Logbook .....	86
Calibration Timer .....	87
Adaptive Calibration Timer .....	87
Tolerance Adjustment .....	87
Cal Record .....	88
Sensor Network Diagram .....	88
Statistics .....	88
Activating Diagnostics.....	91
Message List .....	91
<b>Specifications.....</b>	<b>95</b>



# Contents

---

M700 pH 2700(X)

<b>Appendix: .....</b>	<b>100</b>
Minimum Spans for Current Outputs.....	100
Buffer Table Mettler-Toledo .....	101
Buffer Table Merck / Riedel .....	102
Buffer Table DIN 19267.....	103
Buffer Table NIST Standard (DIN 19266: 2000-01) .....	104
Buffer Table Techn. Buffers to NIST .....	105
Buffer Table Hamilton A.....	106
Buffer Table Hamilton B .....	107
Buffer Table Kraft.....	108
Buffer Sets to be Entered: SW 700-002 .....	109
Index .....	114
Display Icons.....	123
Quick Access .....	124

# Intended Use

---

The module is used for simultaneous pH, ORP and temperature measurement with glass electrodes or ISFET sensors.

The pH 2700X module is intended for operation in locations subject to explosion hazards which require equipment of Group II, device category 2(1), gas/dust.

## Conformity with FDA 21 CFR Part 11

---

In their directive "Title 21 Code of Federal Regulations, 21 CFR Part 11, Electronic Records; Electronic Signatures" the US American health agency FDA (Food and Drug Administration) regulates the production and processing of electronic documents for pharmaceutical development and production. This results in requirements for measuring devices used for corresponding applications. The following features ensure that the M 700(X) modular process analysis system meets the demands of FDA 21 CFR Part 11:

### **Electronic Signature**

Access to the device functions is regulated and limited by individually adjustable codes – "Passcodes". This prevents unauthorized modification of device settings or manipulation of the measurement results. Appropriate use of these passcodes makes them suitable as electronic signature.

### **Audit Trail Log**

Every change of device settings can be automatically recorded and documented in the Audit Trail Log on the SmartMedia card. The recording can be encrypted.

# Safety Information

---

## Application in Hazardous Locations

### **Caution!**

Never try to open the module! If a repair should be required, return the module to our factory.

If the specifications in the instruction manual are not sufficient for assessing the safety of operation, please contact the manufacturer to make sure that your intended application is possible and safe.

### **Be sure to observe during installation:**

- Switch off power supply before replacing or inserting a module.
- Protect the signal inputs of the modules against electrostatic discharge.
- Before commissioning it must be proved that the device may be connected with other equipment.
- Observe correct shielding: To avoid interferences, the cable shielding must be completely covered by the ESD shielding cap.

### **Application in Hazardous Locations:**

#### **pH 2700X Module**

When using the pH 2700X module, the stipulations for electrical installations in hazardous areas (EN 60079-14) must be observed.

When installing the device outside the range of applicability of the 94/9/EC directive, the appropriate standards and regulations in the country of use must be observed. The module has been developed and manufactured in compliance with the applicable European guidelines and standards.

Compliance with the European Harmonized Standards for use in hazardous locations is confirmed by the EC-Type-Examination Certificate.

Compliance with the European guidelines and standards is confirmed by the EC Declaration of Conformity.

There is no particular direct hazard caused by the operation of the device in the specified environment.

# Software Version

pH 2700(X) Module

## Device Software M700(X)

The pH 2700 module is supported by software version 3.0 or higher.  
The pH 2700X module is supported by software version 4.0 or higher.

## Module Software pH 2700(X)

Software version 2.0

Distinguishing between adjustment and calibration: Values determined by a calibration can only be taken over by an adjustment.

## Query actual device/module software

When the analyzer is in measuring mode:  
Press **menu** key, open Diagnostics menu.

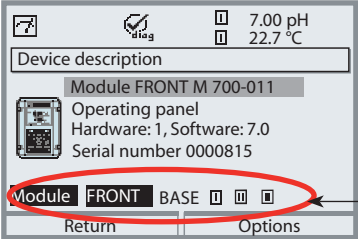
Menu	Display	Device description
		<p>Provides information about all modules installed: Module type and function, serial number, hardware and software version and device options.</p> <p>Select the different modules (FRONT, BASE, slots 1 - 3) using the arrow keys.</p>

# Modular Concept

---

Basic Unit, Measuring Module, Additional Functions

The M 700(X) is an expandable modular process analysis system. The basic unit (FRONT and BASE modules) provides three slots which can be equipped by the user with any combination of measuring or communication modules. The software capabilities can be expanded by additional functions (options). Additional functions must be ordered separately. They are supplied with a device-specific TAN for function release.

## M 700(X) Modular Process Analysis System



### Additional functions

Activation via device-specific TAN



### SmartMedia card

Data recording

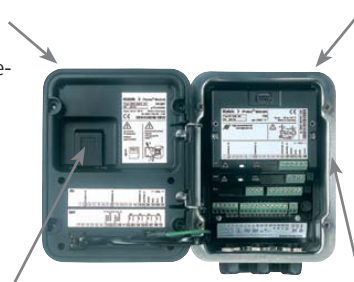

### 3 module slots

for free combination of measuring and communication modules

### Measuring modules

- pH / ORP / Temp
- O<sub>2</sub>/Temp
- Noncontacting conductivity/Temp
- Contacting conductivity/Temp

### Communication modules

- Out (additional switching and current outputs)
- PID (analog and digital controller)
- Profibus PA
- Foundation Fieldbus
- EC 400 probe controller

## Documentation

The basic unit is accompanied by a CD-ROM containing the complete documentation.

Latest product information as well as instruction manuals for earlier software releases are available at [www.mt.com/pro](http://www.mt.com/pro).

# Short Description

## Short Description: FRONT Module

### 4 captive screws

for opening the analyzer

**(Caution!** Make sure that the gasket between FRONT and BASE is properly seated and clean!)

### Transflective LC graphic display

(240 x 160 pixels)

white backlighting, high resolution and high contrast.

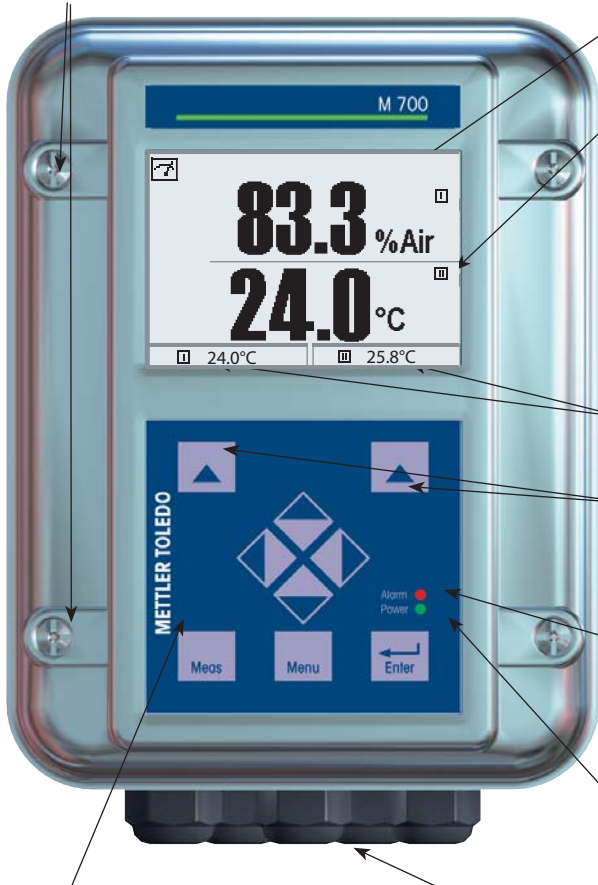

### Measurement display

### User interface

with plaintext menus as recommended by NAMUR.

Menu texts can be switched to: German, English, French, Italian, Swedish, and Spanish.

Intuitively acquirable menu logic, based on Windows standards.

### Secondary displays

### 2 softkeys

with context-sensitive functions.

### Red LED

signals failure (On) or maintenance request/function check (flashing) according to NE 44.

### Green LED

Voltage supply okay

### Control panel

3 function keys

(menu, meas, enter)

and 4 arrow keys for menu selection

and data entries

### 5 self-sealing cable glands

M20 x 1.5

for entry of voltage supply and signal lines

# Short Description: Menu Structure

Basic Functions: Calibration, Maintenance, Parameter Setting, Diagnostics

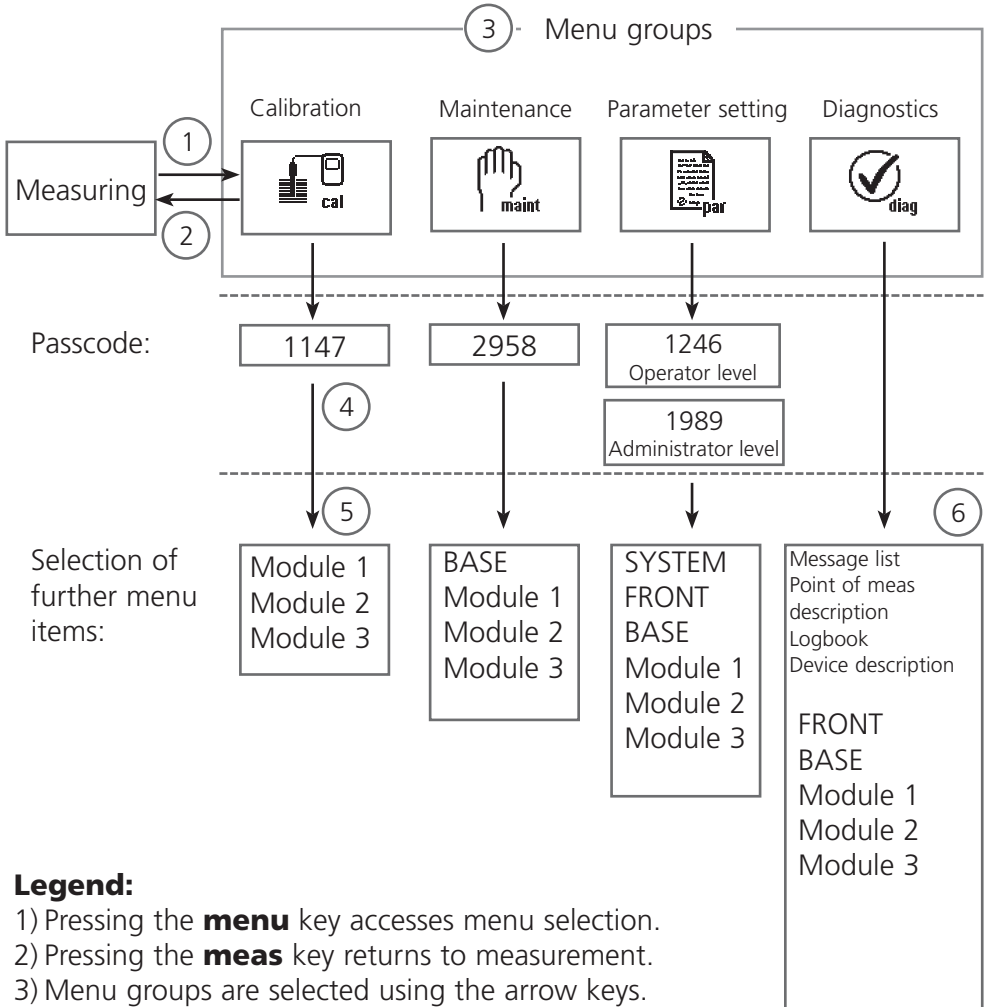

## Legend:

- 1) Pressing the **menu** key accesses menu selection.
- 2) Pressing the **meas** key returns to measurement.
- 3) Menu groups are selected using the arrow keys.
- 4) Press **enter** to confirm, enter passcode.
- 5) Further menu items are displayed.
- 6) Selected functions of the Diagnostics menu can be recalled via softkey even when in measuring mode.

# Short Description: FRONT Module

View into the open device (FRONT module)

## Slot for SmartMedia card

- Data recording  
The SmartMedia card expands the measurement recorder capacity to > 50000 records.
- Exchange of parameter sets  
5 parameter sets can be stored on the SmartMedia card. The 2 internal parameter sets can be switched by remote control. Configurations can be transmitted from one analyzer to the other.
- Function expansions  
are possible with additional software modules, which are released using transaction numbers (TAN)
- Software updates

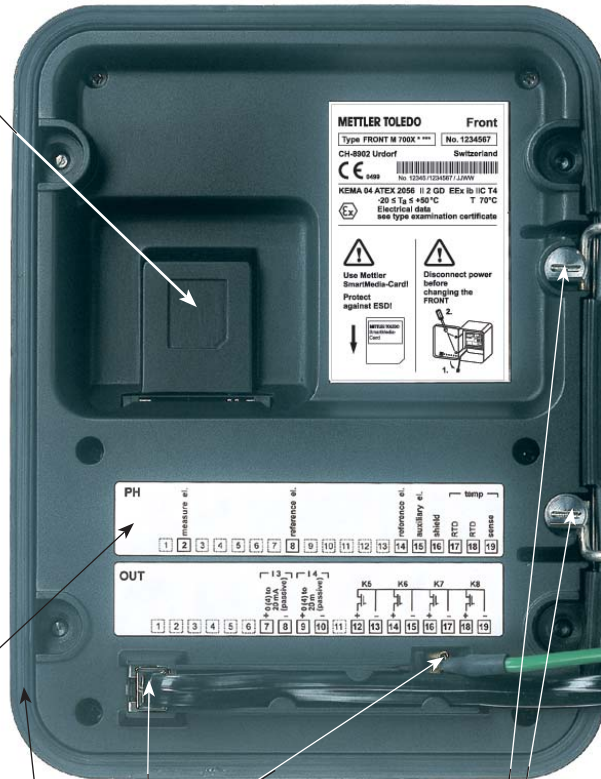

## Terminal plates of "hidden" modules

Each module comes with an adhesive label containing the contact assignments. This label should be stuck to the inner side of the front (as shown). Then, the terminal assignments remain visible even if further modules are inserted.

## Replacing the front module

Pull off power cord and ground wire. To separate the FRONT module from the BASE module, turn the retaining screws of the pivot hinge by 90°.

## The circumferential sealing

guarantees IP 65 protection and allows spray cleaning / disinfection.

**Caution!** Keep clean!



# Short Description: BASE Module

View into the open device (BASE module, 3 function modules installed)

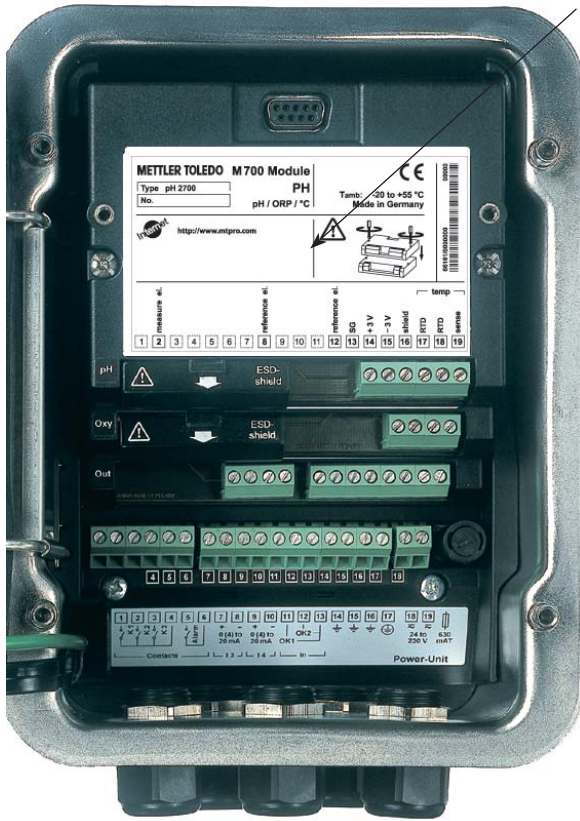

## Module equipment

Module identification: Plug & Play.

Up to 3 modules can be combined as desired. Several input and communication modules are available.

## BASE module

2 current outputs (free assignment of process variable) and 4 relay contacts, 2 digital inputs.

VariPower broad-range power supply, 20 ... 265 V AC/DC, suitable for all public mains supplies in the world.

## Power supply units, IS version:

100 ... 230 V AC or  
24 V AC/DC



## Warning!

**Do not touch the terminal compartment, there may be dangerous contact voltages!**

## Important Notice Concerning SmartMedia Card

The SmartMedia card may be inserted or replaced with the power supply switched on. Before a memory card is removed, it must be "closed" in the maintenance menu. When closing the device, make sure that the sealing is properly seated and clean.



# Terminal Plate pH 2700(X) Module

## Terminal Plate pH 2700 Module:

<b>METTLER TOLEDO M 700 Module</b>											<b>CE</b>		00000										
Type pH 2700		<b>PH</b>		Tamb: -20 to +55 °C																			
No. <input type="text"/>		pH / ORP / °C		Made in Germany																			
Internet <a href="http://www.mt.com">http://www.mt.com</a>															665161/0000000		00000						
measure el.		reference el.		reference el.		temp																	
1	2	3	4	5	6	7	8	9	10	11	12	13	14	15	16	17	18	19					
										SG		+3 V		-3 V		shield		RTD		RTD		sense	

## Terminal Plate pH 2700X Module:

<b>METTLER TOLEDO M 700X Module</b>											<b>SP</b>		<b>FM</b> APPROVED		<b>Ex</b>		<b>CE</b>		0049		00000			
Type pH 2700 X		<b>PH</b>		Tamb: -20 to +50 °C																				
No. <input type="text"/>		pH / ORP / °C		Made in Germany/Kassel																				
<b>Ex</b> KEMA 04 ATEX 2056 Electr. data see type examination certificate II 2 (1) GD EEx ib [ia] IIC T4 T 70 °C CH-8902 Urdorf Switzerland																								
<b>FM</b> IS, CLASS I, DIV1, GRP A, B, C, D, T4 Entity, T <sub>a</sub> = 50 °C CLASS I, ZONE 1, AEx ib [ia], GRP IIC, T4 control dwg. 201.004-110																								
<b>SP</b> NI, CII, DIV 2, GRP A, B, C, D with IS circuits extending into DIV 1 AIS, CI I, Zone 1, Ex ib [ia] IIC T4 NI, CII, Zone 2, Ex na [ia] IIC control dwg. 201.004-120																								
pH sensor																								
measure electrode		reference electrode		reference electrode		temp																		
1	2	3	4	5	6	7	8	9	10	11	12	13	14	15	16	17	18	19						
										SG		+3 V		-3 V		shield		RTD		RTD		sense		

## Attaching the Terminal Plates

The terminal plates of the lower modules can be stuck to the inner side of the door. This facilitates maintenance and service.



# Inserting the Module

---

Note: Be sure to connect the shielding properly!



The terminals 2 and 8 are covered by an ESD shield. To connect the sensor cable, just pull it back.

Make sure that the cable glands are tightly closed to protect against humidity.

1. Switch off power supply
2. Open the device (loosen the 4 screws at the front)
3. Place module in slot (D-SUB connector)
4. Tighten fastening screws of the module
5. Open ESD shielding cap (covering terminals 2 and 8)
6. Connect sensor cable.  
To avoid interferences, the cable shielding must be completely covered by the ESD shielding cap.
7. Close ESD shielding cap (covering terminals 2 and 8)
8. Close device, tighten screws at the front
9. Switch on power supply
10. Set parameters

# Wiring Examples

**Note:** Be sure to connect the shielding properly!  
See EC-Type-Examination Certificate ([www.mt.com/pro](http://www.mt.com/pro)) for Ex ratings.

## Wiring Example 1

Connection of VP cable  
pH measurement with monitoring of glass electrode

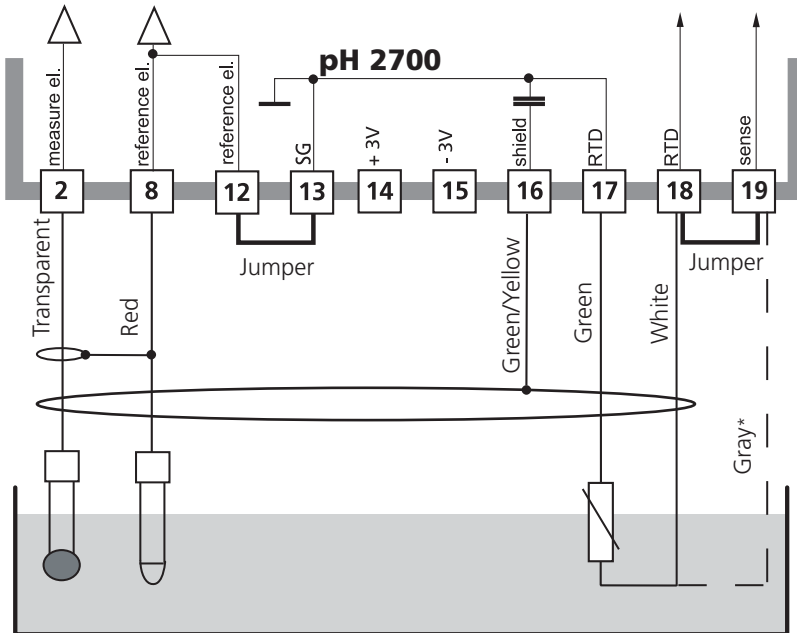

\* For electrodes with Pt100, remove jumper 18/19  
and connect gray wire

# Wiring Example 2

Connection of VP cable

pH measurement with monitoring of glass and reference electrode

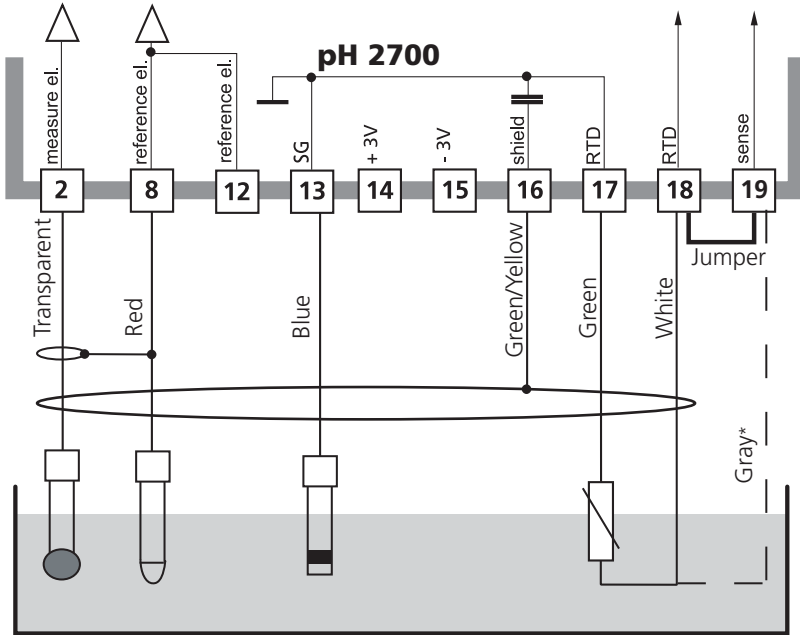

\* For electrodes with Pt100, remove jumper 18/19 and connect gray wire

# Wiring Example 3

pH measurement with monitoring of glass electrode

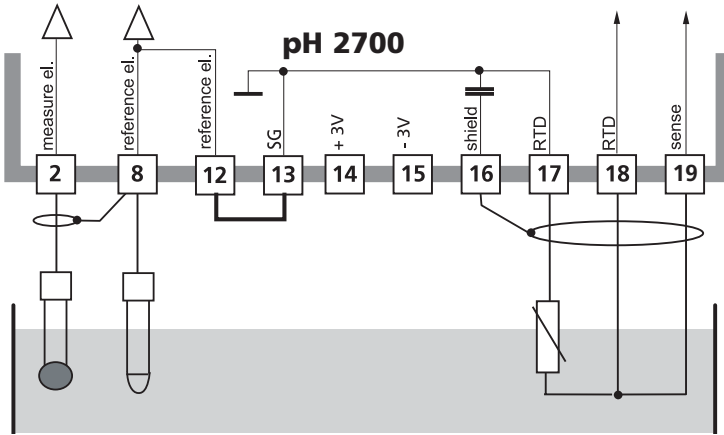

# Wiring Example 4

Simultaneous pH and ORP measurement with monitoring of glass and reference electrode

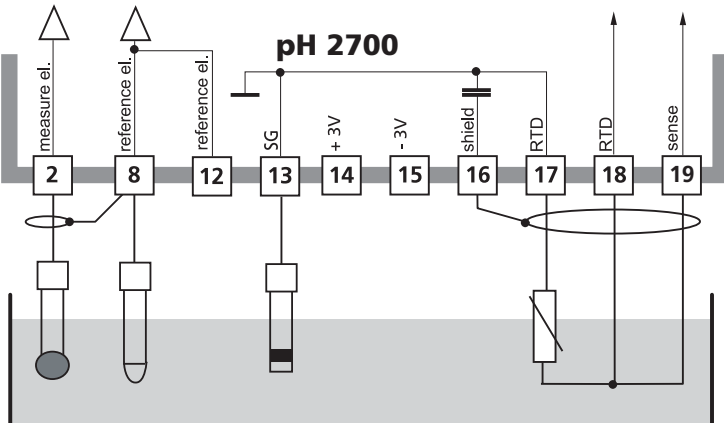

# Wiring Example 5

ORP (redox) measurement with monitoring of reference electrode

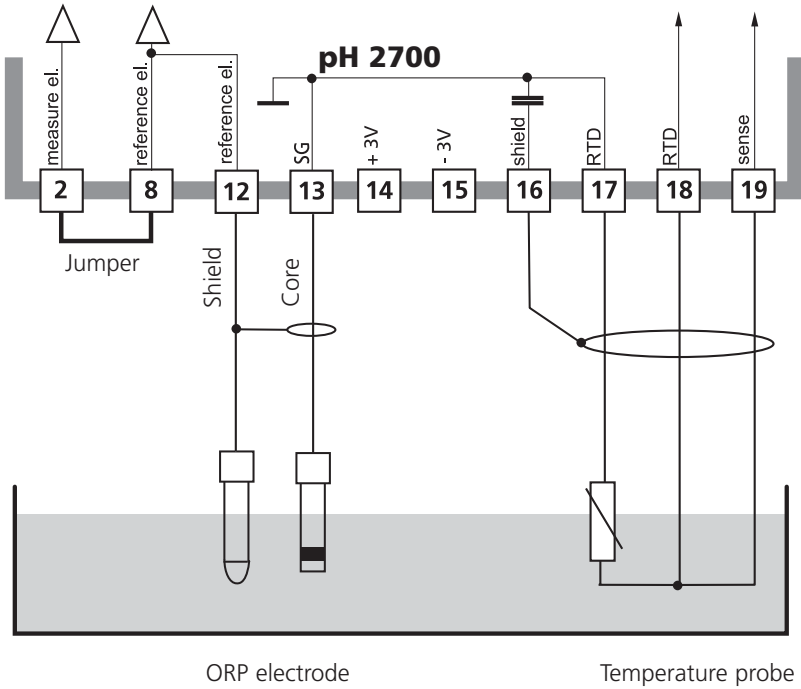



# Wiring Example 6

pH measurement with InPro 3300 ISFET sensor

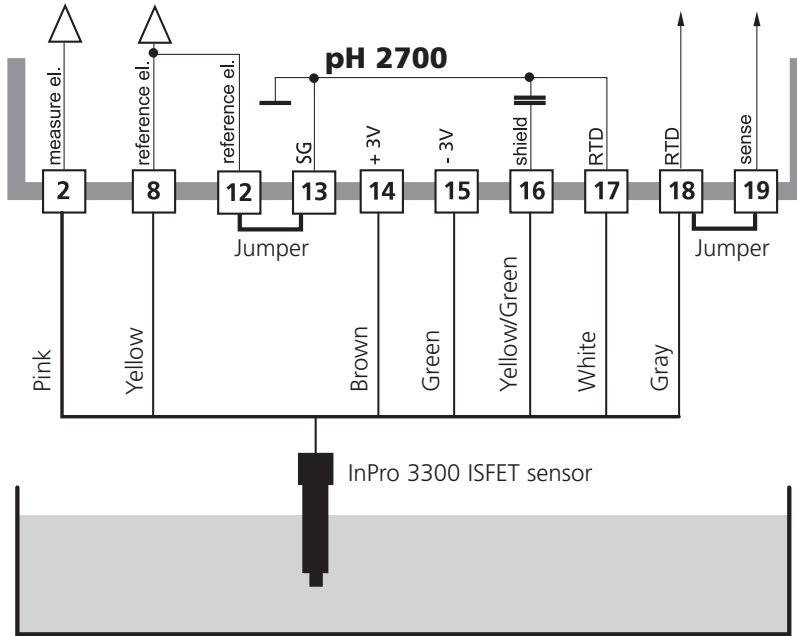

## Notice:

Each time a new sensor is connected, you must perform an ISFET zero adjustment to adjust the operating point.

After that, you should perform one of the following calibration methods:

- Calimatic: automatic calibration
- Manual entry of buffer values
- Data entry: premeasured electrodes

# Menu Selection

After switching on, the analyzer performs an internal test routine and automatically detects the number and type of modules installed. Then, the analyzer goes to measuring mode.

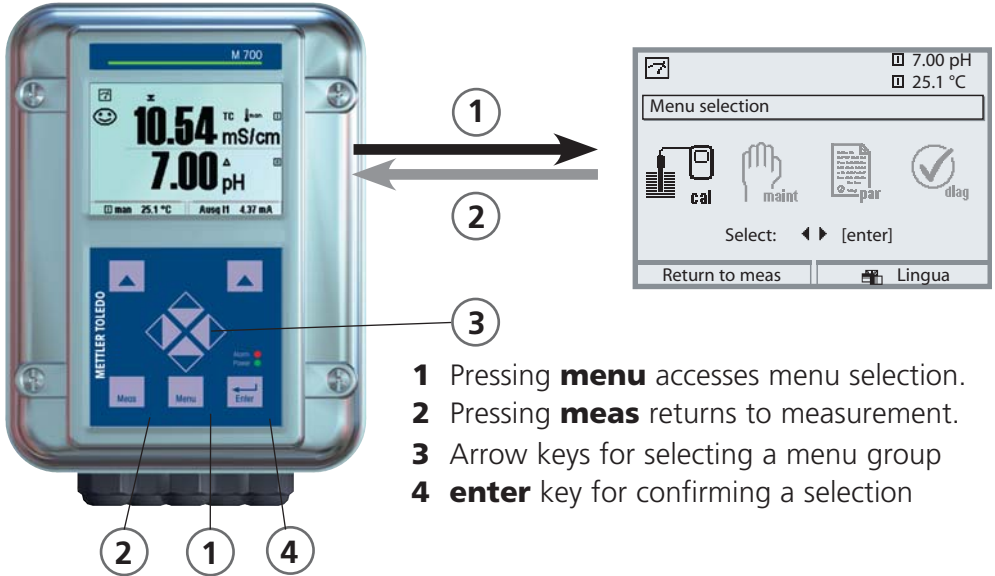

- 1 Pressing **menu** accesses menu selection.
- 2 Pressing **meas** returns to measurement.
- 3 Arrow keys for selecting a menu group
- 4 **enter** key for confirming a selection

# Menu Structure

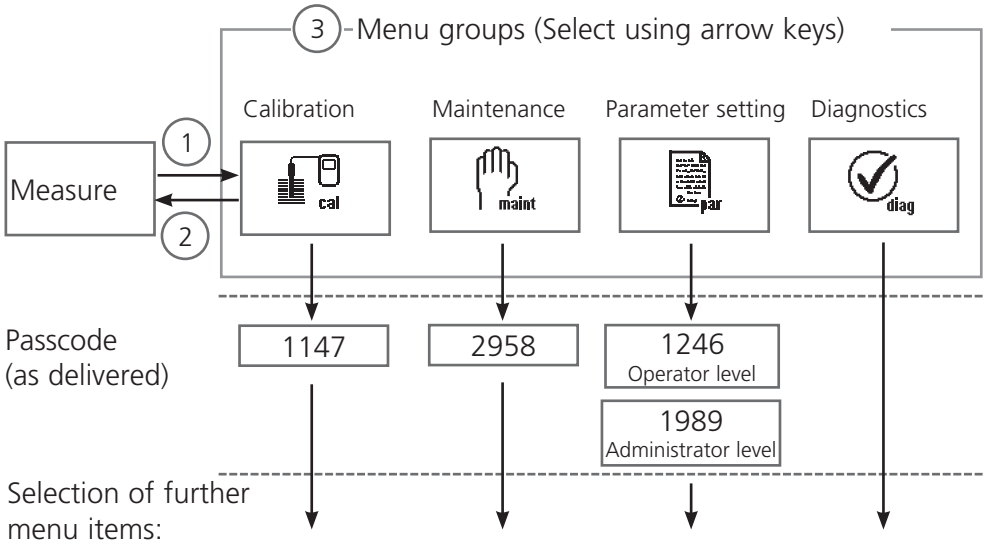

# Passcode Entry

## To enter a passcode

Select the position using the left/right keys, then edit the number using the up/down keys.

When all numbers have been entered, confirm with **enter**.

## To change a passcode

- Open the menu selection (**menu**)
- Select parameter setting
- Administrator level, enter passcode
- Select System control: Passcode entry

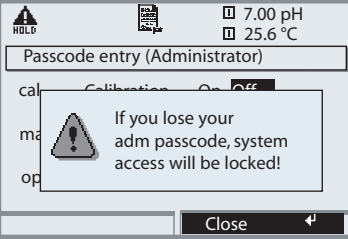
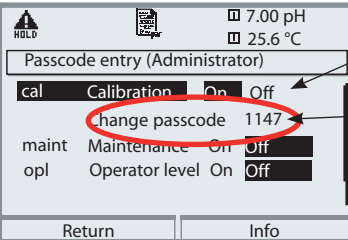
Menu	Display	System control: Passcode entry								
	 	<h3>System control: Passcode entry</h3> <h4>Changing a passcode "Passcode entry" menu</h4> <p>When this menu is opened, the analyzer displays a warning (Fig.).</p> <p>Passcodes (factory settings):</p> <table><tr><td>Calibration</td><td>1147</td></tr><tr><td>Maintenance</td><td>2958</td></tr><tr><td>Operator level</td><td>1246</td></tr><tr><td>Administrator level</td><td>1989</td></tr></table> <h4>If you lose the passcode</h4> <p>for the Administrator level, system access will be locked! Please consult our technical support!</p> <h4>To change a passcode</h4> <p>Select "On" using arrow keys, confirm with <b>enter</b>.</p> <p>Select the position using the <b>left/right</b> keys, then edit the number using the <b>up/down</b> keys.</p> <p>When all numbers have been entered, confirm with <b>enter</b>.</p>	Calibration	1147	Maintenance	2958	Operator level	1246	Administrator level	1989
Calibration	1147									
Maintenance	2958									
Operator level	1246									
Administrator level	1989									

# Configuring the Measurement Display

Select menu: Parameter setting/Module FRONT/Measurement display

Pressing **meas** (1) returns the analyzer to the measuring mode from any function.

All process variables coming from the modules can be displayed. The table on the next page describes how to configure the measurement display.

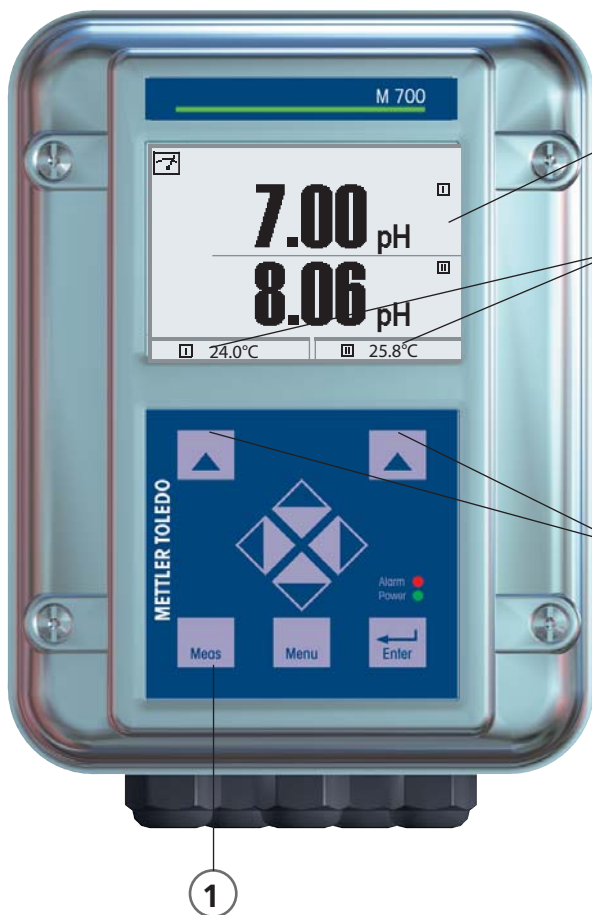

## Measurement display



Typical display for 2 pH measurement points.

## Secondary displays

Additional values, also date and time, can be displayed depending on the modules installed.

## Softkeys

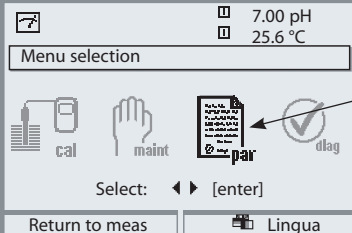
In measuring mode, the softkeys allow selection of values for the secondary displays or control of functions (user defined).

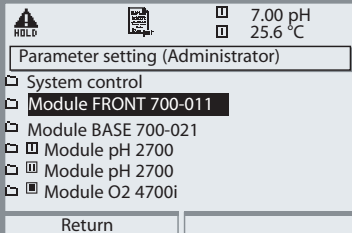
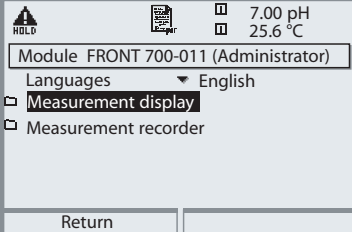
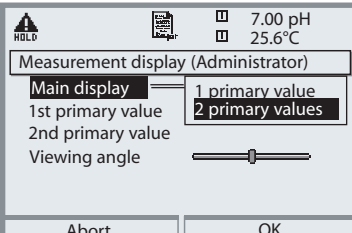
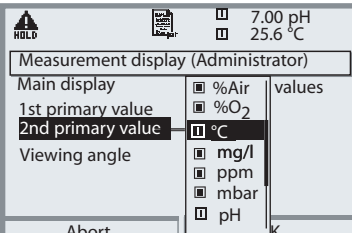
Menu	Display	Configure measurement display
		<p><b>Configure measurement display</b></p> <p>Press <b>menu</b> key to Menu selection          Select parameter setting using arrow keys, confirm with <b>enter</b>. Select:          "Administrator level": Passcode 1989          (default setting).</p>
		<p>Parameter setting:          Select "Module FRONT"</p>
		<p>Front module:          Select "Measurement display"</p>
		<p>Measurement display:          Set the number of primary values          (large display) to be displayed</p>
		<p>Select process variable(s)          to be displayed          and confirm with <b>enter</b>.</p> <p>Pressing the <b>meas</b> key returns to          measurement.</p>

# Calibration / Adjustment

---

**Note:** HOLD mode active for the currently calibrated module  
Current outputs and relay contacts behave as configured

- **Calibration:** Detecting deviations without readjustment
- **Adjustment:** Detecting deviations with readjustment

## **Caution:**

Without adjustment every pH meter delivers an imprecise or wrong output value! Every pH electrode has its individual zero point and its individual slope. Both values are altered by aging and wear.

To determine the correct pH value, the pH meter must be adjusted to the electrode. The analyzer corrects the voltage delivered by the electrode with regard to electrode zero and slope and displays it as the pH value.

Be sure to perform an adjustment after having replaced the electrode!

## **Procedure**

First, a calibration is performed to detect the deviations of the electrode (zero, slope). To do so, the electrode is immersed in buffer solutions whose pH value is exactly known. The measuring module measures the electrode voltages and the buffer solution temperature and automatically calculates the electrode zero and slope. These data are stored in a calibration record. By "Adjustment" the determined calibration data can be used for correction (see following page).

## **Parameters Determined by Calibration**

**Zero** is the pH value at which the pH electrode outputs the voltage 0 mV. It is different for each electrode and changes with age and wear.

**Temperature** of the process solution must be detected since pH measurement is temperature-dependent. Many electrodes have an integrated temperature probe.

**Slope** of an electrode is the voltage change per pH unit. For an ideal pH electrode, it lies at  $-59.2 \text{ mV/pH}$ .

# Adjustment

Adjustment means that the values determined by a calibration are taken over. The values determined for zero and slope are entered in the calibration record. (Cal record can be called up in the Diagnostics menu for the pH 2700(X) module). These values are only effective for calculating the measured variables when the calibration has been terminated with an adjustment. A passcode ensures that an adjustment can only be performed by an authorized person (Administrator). The Operator can check the current sensor data by a calibration and inform the Administrator when there are deviations. You can use the additional function SW 700-107 for granting access rights (passcodes) and for AuditTrail (continuous data recording and backup according to FDA 21 CFR Part 11).

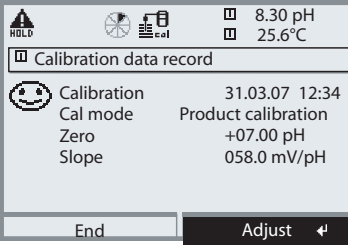
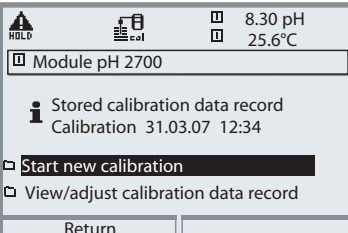
Menu	Display	Adjustment after calibration
		<p><b>Administrator</b></p> <p>With the corresponding access rights, the device can immediately be adjusted after calibration. The calibration values are taken over for calculating the measured variables.</p>
		<p><b>Operator</b> (without administrator rights)</p> <p>After calibration, change to measuring mode. Inform Administrator. When opening the menu (Calibration, respective module), the Administrator sees all data of the last calibration and can take over the values or perform a new calibration.</p>

# Calibration / Adjustment

---

## Calibration Methods

### **One-Point Calibration**

The electrode is calibrated with one buffer solution only.

Here, only the electrode zero point is detected and taken into account by the M 700. One-point calibration is appropriate and permissible whenever the measured values lie near the electrode zero point so that slope changes do not have much of an impact.

### **Two-Point Calibration**

The electrode is calibrated with two buffer solutions.

In that case, zero point and slope of the electrode can be detected and taken into account by the M 700. Two-point calibration is required if

- the electrode has been replaced
- the measured pH values cover a wide range
- there is great difference between the measured pH value and the electrode zero
- the pH measurement must be very accurate,
- the electrode is exposed to extreme wear.

### **Three-Point Calibration**

The electrode is calibrated with three buffer solutions.

Zero and slope are calculated using a line of best fit according to DIN 19268.

### **Sensor Replacement (First Calibration)**

A First Calibration must be performed each time the electrode is replaced.

During First Calibration, the electrode data together with the electrode type and serial number are stored as reference values for electrode statistics.

The "Statistics" menu of Diagnostics shows the deviations of zero, slope, glass and reference electrode impedance, and response time of the last three calibrations with respect to the reference values of the First Calibration.

This allows evaluation of the drift behavior and aging of the electrode.



# Calibration / Adjustment

## Temperature Compensation

### Temperature Compensation During Calibration

There are two important reasons for determining the temperature of the buffer solution:

The slope of the pH electrode is temperature-dependent. Therefore the measured voltage must be corrected by the temperature influence.

The pH value of the buffer solution is temperature-dependent. For calibration, the buffer solution temperature must therefore be known in order to choose the actual pH value from the buffer table.

During parameter setting you define whether cal temperature is measured automatically or must be entered manually:

### Automatic Temperature Compensation

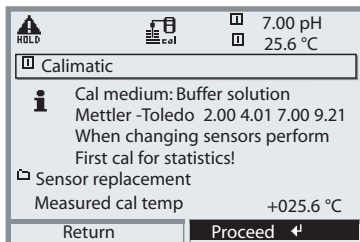

For automatic cal temp detection, the M700 measures the temperature of the buffer solution with a temperature probe (Pt 100/Pt 1000/NTC 30 k $\Omega$ /NTC 8.55 k $\Omega$ ). If you work with automatic temperature compensation during calibration, a temperature probe connected to the temperature input of the M 700 must be in the buffer solution! Otherwise, you must select

manual entry of calibration temperature. When "Cal temp automatic" is set, "Measured cal temp" appears in the menu.

### Manual Temperature Compensation

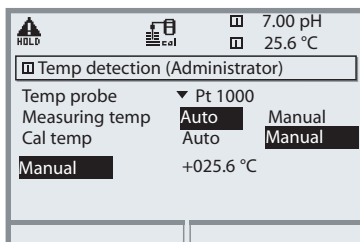

The temperature of the buffer solution must be entered manually in the Parameter setting menu at "Parameter setting / <pH module> / Sensor data / Temp detection / Cal temp --> manual". Temperature measurement is performed using a glass thermometer, for example.

# Calibration / Adjustment

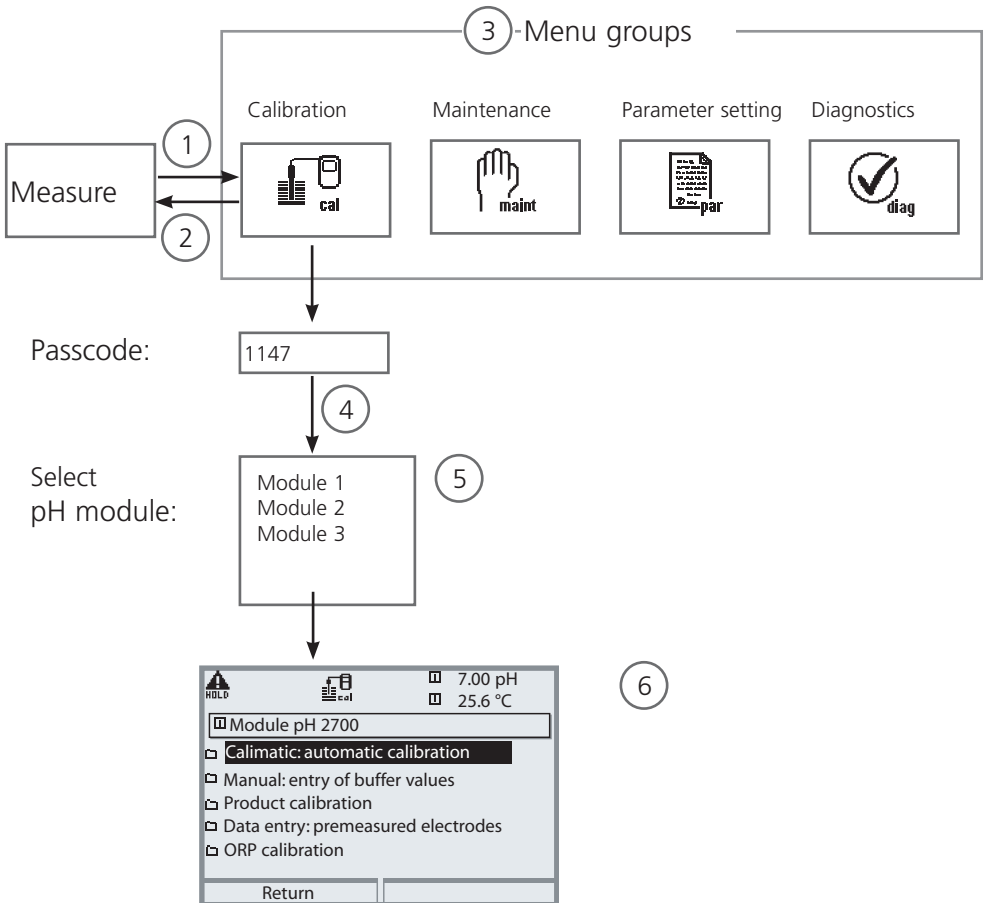

## Selecting a Calibration Method

The HOLD mode is active for the currently calibrated module, the current outputs behave as configured.

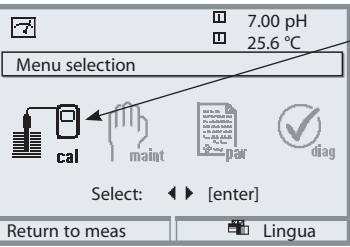

To calibrate a pH module: Select a calibration method

- (1) Press **menu** key to access menu selection
- (2) Pressing the **meas** key returns to measurement
- (3) Select Calibration menu group using the arrow keys
- (4) Press **enter** to confirm, enter passcode
- (5) Select pH module, confirm with **enter**.
- (6) Select calibration method

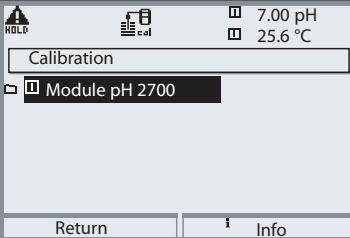
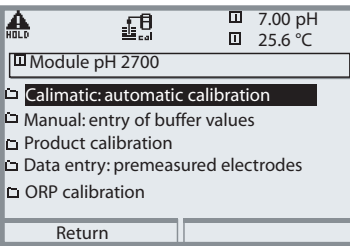
Menu	Display	Select calibration method (pH)
		<p><b>To call up calibration</b></p> <p>Press <b>menu</b> key to select menu. Select calibration using arrow keys, confirm with <b>enter</b>, passcode 1147 (To change passcode, select: Parameter setting / System control / Passcode entry)</p> <p>After passcode entry, the system is in HOLD mode: Current outputs and relay contacts of the currently calibrated module behave as configured (BASE) until the Calibration menu is exited.</p>
		<p>Calibration: Select "Module pH"</p>
		<p>Select calibration method:</p> <ul style="list-style-type: none"> <li>• Automatic buffer recognition</li> <li>• Manual entry of buffer values</li> <li>• Product calibration (Calibration with sampling)</li> <li>• Data entry of premeasured electrodes</li> <li>• ORP calibration/adjustment</li> <li>• ISFET zero adjustment</li> </ul> <p>When you open the Calibration menu, the analyzer automatically proposes the previous calibration method. If you do not want to calibrate, press the "Return" softkey or the <b>meas</b> key.</p>

# Calibration / Adjustment

## Calimatic Automatic Buffer Recognition

### Automatic Buffer Recognition (Calimatic)

Automatic calibration ("Calimatic") is performed with one, two, or three buffer solutions. The M 700 automatically detects the nominal buffer value on the basis of the electrode potential and the measured temperature. Any sequence of buffer solutions is possible, but they must belong to the buffer set defined during parameter setting.



The Calimatic takes the temperature dependence of the buffer value into account. All calibration data is converted using a reference temperature of 25 °C.

**During calibration the module is in HOLD mode.** Current outputs and relay contacts of the module behave as configured (BASE module).

### Caution!

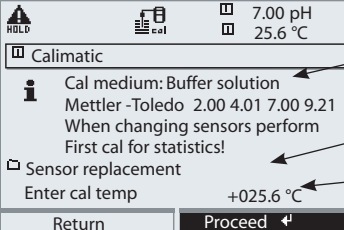
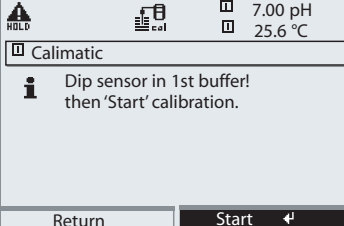
Only ever use fresh, undiluted buffer solutions which belong to the selected buffer set!

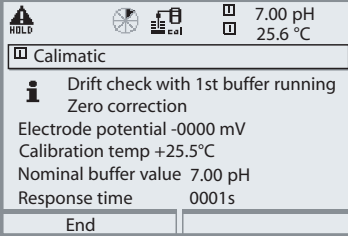
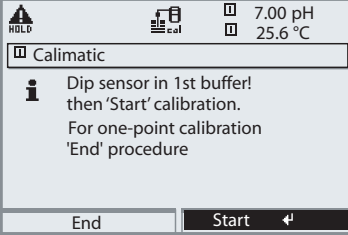
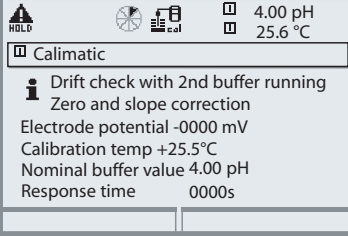
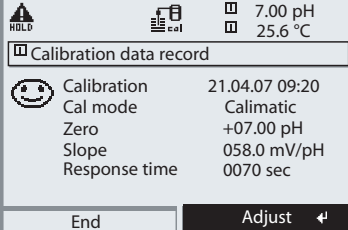
Menu	Display	Automatic buffer recognition
		<p><b>Select: Calimatic</b></p> <p>Display of selected buffer set</p> <p>Select: Sensor replacement</p> <p>Enter: calibration temp</p> <p>Proceed with softkey or <b>enter</b></p>
		<p>Remove and rinse the electrode (<b>Caution:</b> Do not rub! Electrostatic hazard!), then immerse it in the first buffer solution.</p> <p>Start with softkey or <b>enter</b></p>

Menu	Display	Automatic buffer recognition
	 <p>Calimatic</p> <p><b>i</b> Drift check with 1st buffer running Zero correction Electrode potential -0000 mV Calibration temp +25.5°C Nominal buffer value 7.00 pH Response time 0001s</p> <p>End</p>	<p>Display of nominal buffer value. You can press "End" to reduce the waiting time before stabilization of the electrode potential (reduced accuracy of calibration values). From the response time, you see how much time the electrode needs for the potential to stabilize. If the electrode potential or the measured temperature fluctuate greatly, the calibration procedure is aborted after 2 min.</p>
	 <p>Calimatic</p> <p><b>i</b> Dip sensor in 1st buffer! then 'Start' calibration. For one-point calibration 'End' procedure</p> <p>End      Start ↵</p>	<p>For a one-point calibration, press "End" softkey. For two-point calibration: Rinse electrode thoroughly! Immerse electrode in the second buffer solution. Start with softkey or <b>enter</b></p>
	 <p>Calimatic</p> <p><b>i</b> Drift check with 2nd buffer running Zero and slope correction Electrode potential -0000 mV Calibration temp +25.5°C Nominal buffer value 4.00 pH Response time 0000s</p>	<p>Calibration is performed with the second buffer.  Three-point calibration is performed correspondingly with the third buffer.</p>
	 <p>Calibration data record</p> <p> Calibration 21.04.07 09:20 Cal mode Calimatic Zero +07.00 pH Slope 058.0 mV/pH Response time 0070 sec</p> <p>End      Adjust ↵</p>	<p><b>Adjustment</b> Press "Adjust" to take over the values determined during calibration for calculating the measured variables.</p>

# Calibration / Adjustment

## Calibration with Manual Entry of Buffer Values

### Calibration with Manual Entry of Buffer Values

Calibration with manual entry of buffer values is performed with one, two, or three buffer solutions.

M 700 displays the measured temperature.

You must then enter the temperature-corrected buffer values. To do so, refer to the buffer table (e.g. on the bottle) and enter the buffer value belonging to the displayed temperature.













Intermediate values must be interpolated.





















All calibration data is converted using a reference temperature of 25 °C.

**During calibration the module is in HOLD mode.** Current outputs and relay contacts of the module behave as configured (BASE module).

### Caution!

Only ever use fresh, undiluted buffer solutions!

Menu	Display	Manual entry
	   7.00 pH  25.6 °C Manual entry  Cal medium: Buffer solution When changing sensors perform First cal for statistics!  Sensor replacement Cal temp +025.6 °C First buffer solution +04.00 pH Return Proceed ↵	<b>Select: Manual entry</b>  Select: Sensor replacement Display: calibration temp Enter first buffer value Proceed with softkey or <b>enter</b>
	   7.00 pH  25.6 °C Manual entry  Dip sensor in 1st buffer! then 'Start' calibration. Return Start ↵	Remove and rinse the electrode <b>(Caution: Do not rub!</b> Electrostatic hazard!), then immerse it in the first buffer solution. Start with softkey or <b>enter</b>

Menu	Display	Manual entry
 	     4.00 pH 25.6 °C Manual entry <i>i</i> Drift check with 1st buffer running. Zero correction Electrode potential -0224 mV Calibration temp +25.6°C Nominal buffer value +04.00 pH Response time 0018s End	<p>Calibration with first buffer solution. You can press “End” to reduce the waiting time before stabilization of the electrode potential (reduced accuracy of calibration values). From the response time, you see how much time the electrode needs for the potential to stabilize. If the electrode potential or the measured temperature fluctuate greatly, the calibration procedure is aborted after 2 min.</p>
	    7.00 pH 25.6 °C Manual entry <i>i</i> Dip sensor in 1st buffer! then ‘Start’ calibration. For one-point calibration ‘End’ procedure Second buffer solution +07.00 pH End      Start ←	<p>One-point calibration: “End”. Two-point calibration: Rinse electrode thoroughly! Enter 2nd buffer value for correct temperature. Immerse electrode in the second buffer solution. Start with softkey or <b>enter</b></p>
	     7.00 pH 25.6 °C Manual entry <i>i</i> Drift check with 2nd buffer running Zero and slope correction Electrode potential -0000 mV Calibration temp +25.6°C Nominal buffer value +07.00 pH Response time 0007s End	<p>Calibration is performed with the second buffer.  Three-point calibration is performed correspondingly with the third buffer.</p>
	    7.00 pH 25.6 °C Calibration data record  Calibration 31.03.07 09:20 Cal mode Manual input Zero +07.00 pH Slope 058.0 mV/pH Response time 0070 sec End      Adjust ←	<p><b>Adjustment</b> Press “Adjust” to take record of the values determined during calibration for calculating the measured variables.</p>

# Calibration / Adjustment

## Product Calibration

### Product Calibration (Calibration with Sampling)

When the electrode cannot be removed – e.g. for sterility reasons – its zero point can be determined with “sampling”. To do so, the currently measured process value is stored by the M 700. Immediately afterwards, you take a sample from the process. The pH value of the sample is measured in the lab or directly on the site using a portable pH meter. The reference value is entered into the measuring system. From the difference between measured value and reference value, the M 700 calculates the electrode zero point (this method only allows one-point calibration).

**During calibration the module is in HOLD mode.** Current outputs and relay contacts of the module behave as configured (BASE).

**Caution!** The pH value of the sample is temperature-dependent. Therefore, the reference measurement should be performed at the sample temperature shown in the display. Transport the sample in an insulated container. The pH value may also be altered due to escaping of volatile substances.

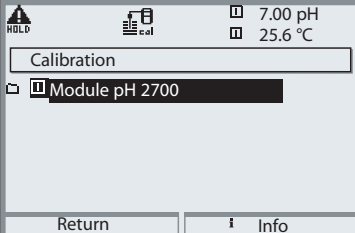
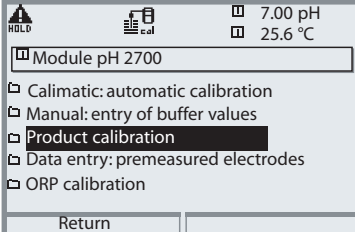
Menu	Display	Product calibration
		<p><b>Select module: pH 2700</b></p> <p>The module is in HOLD mode. The assigned current outputs and relay contacts behave as configured (BASE). Confirm with <b>enter</b>.</p>
		<p>Select calibration mode “Product calibration”</p> <p>Confirm with <b>enter</b>.</p>

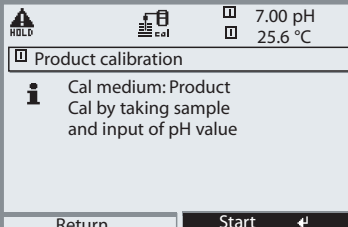
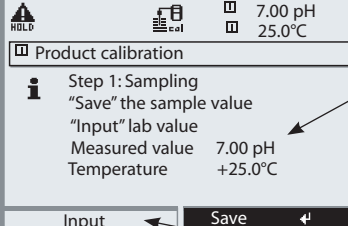
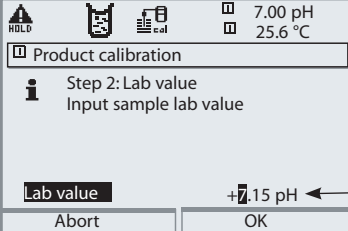
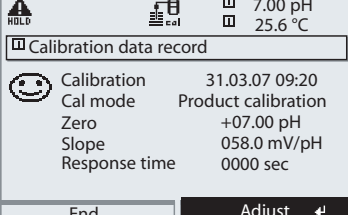

Menu	Display	Product calibration
	 <p>Product calibration</p> <p>Cal medium: Product Cal by taking sample and input of pH value</p> <p>Return      Start ↵</p>	<p><b>Product Calibration</b></p> <p>Product calibration is performed in 2 steps. Prepare sampling, Start with softkey or <b>enter</b>.</p>
	 <p>Step 1: Sampling "Save" the sample value "Input" lab value Measured value    7.00 pH Temperature        +25.0°C</p> <p>Input ←      Save ↵</p>	<p><b>Step 1</b></p> <p>Take sample. Store measured value and temperature at the moment of sampling ("Save" softkey or <b>enter</b>) Press <b>meas</b> to return to measurement.</p> <p><b>Exception:</b> Sample value can be measured on the site and be entered immediately. To do so, press "Input" softkey.</p>
	 <p>Step 2: Lab value Input sample lab value</p> <p>Lab value                    +7.15 pH ←</p> <p>Abort                      OK</p>	<p><b>Step 2</b></p> <p>Lab value has been measured. When you open the Product calibration menu again, the display shown on the left appears: Enter reference value ("Lab value"). Confirm with OK or repeat calibration.</p>
	 <p>Calibration data record</p> <p>☺ Calibration            31.03.07 09:20 Cal mode            Product calibration Zero                    +07.00 pH Slope                  058.0 mV/pH Response time       0000 sec</p> <p>End                      Adjust ↵</p>	<p><b>Adjustment</b></p> <p>Press "Adjust" to take over the values determined during calibration for calculating the measured variables.</p>

# Calibration / Adjustment

Calibration by Entering Data from Premeasured Electrodes

## Data Entry of Premeasured Electrodes

Entry of values for zero point, slope, and isothermal potential of a pH electrode. The values must be known, e.g. determined beforehand in the laboratory.

**Caution!** Input of an isothermal potential  $V_{iso}$  also applies to the calibration methods

- Calimatic
- Manual input and
- Product calibration.

For an explanation of the isothermal potential, refer to Pg 43.

**During calibration the module is in HOLD mode.** Current outputs and relay contacts of the module behave as configured (BASE).

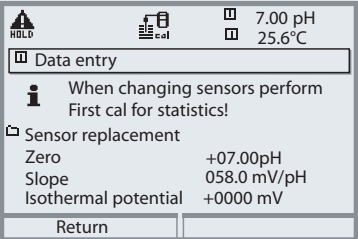
Menu	Display	Manual entry
		<p><b>Select: Data entry of premeasured electrodes</b></p> <p>Remove electrode and connect premeasured electrode. Call up "Sensor replacement". Enter the values for</p> <ul style="list-style-type: none"> <li>• Zero</li> <li>• Slope</li> <li>• Isothermal potential</li> </ul> <p>Return with softkey. Return to measurement with <b>meas</b></p>

## Isothermal Potential

The isothermal intersection point is the point of intersection between two calibration lines at two different temperatures. The potential difference between the electrode zero point and this intersection point is the isothermal potential "Viso".

It may cause measurement errors depending on the temperature. These errors can be compensated for by defining the "Viso" value.

- Measurement errors are avoided by calibrating at measuring temperature or at a controlled and stable temperature.

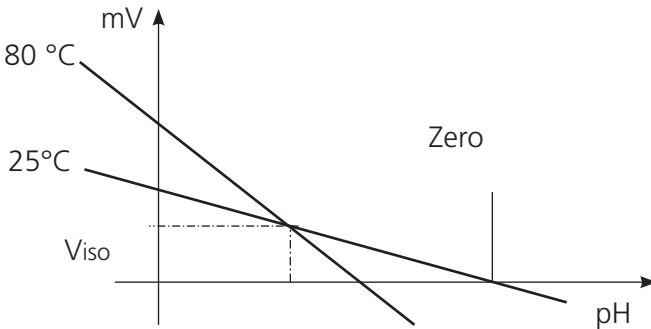

## Monitoring Functions for Calibration

The M 700 provides comprehensive functions for monitoring proper calibration performance and the electrode condition. This allows documentation for quality management to ISO 9000 and GLP/GMP.

- Sensocheck monitors the electrode condition by measuring the glass and reference electrode impedances.
- Regular calibration can be monitored by the cal timer.
- Adaptive cal timer - automatically reduces the calibration interval when the electrode is subjected to high stress
- The calibration record (GLP/GMP) provides all relevant data of the last calibration and adjustment.
- The statistics show the behavior of the electrode parameters during the last three calibrations compared to the First Calibration.
- The logbook shows the time and date of a performed calibration.

# Calibration / Adjustment

---

## ORP Calibration/Adjustment

### ORP Calibration/Adjustment

The potential of a redox electrode is calibrated using a redox (ORP) buffer solution. In the course of that, the difference between the measured potential and the potential of the calibration solution is determined. This potential difference is printed on the calibration solution bottle and is defined as the voltage across the redox electrode and a reference electrode.

Examples: 220 mV Pt against Ag/AgCl, KCl 3 mol/l  
427 mV Pt against SHE

During measurement this difference is added to the measured potential.

$$mV_{\text{ORP}} = mV_{\text{meas}} + \Delta mV$$

$mV_{\text{ORP}}$  = displayed oxidation-reduction potential (measured ORP)

$mV_{\text{meas}}$  = direct electrode potential (ORP input, see Sensor monitor)

$\Delta mV$  = delta value, determined during calibration

### ORP Related to the Standard Hydrogen Electrode (SHE)

The oxidation-reduction potential can also be calibrated automatically with respect to the standard hydrogen electrode (SHE). To do so, you must first select the reference electrode used (see Parameter setting).

The temperature behavior of the reference electrode is automatically taken into account.

You can choose from the following types of reference electrodes:

Ag/AgCl, KCl 1 mol/l (Silver/silver chloride)

Ag/AgCl, KCl 3 mol/l (Silver/silver chloride)

Hg, Tl/TlCl, KCl 3.3 mol/l (Thalimid)

Hg/Hg<sub>2</sub>SO<sub>4</sub>, K<sub>2</sub>SO<sub>4</sub> saturated (Mercury sulfate)

Menu	Display	ORP adjustment
	<div style="float: right;">200 mV 25.6 °C</div> <p>ORP adjustment</p> <p>Reference electrode Ag/AgCl,KCl 1m</p> <p>Temperature 25 ml</p> <p>ORP input +200 mV</p> <p>ORP setpoint +200 mV</p> <p>Return</p>	<p>The type of reference electrode is selected during parameter setting. Immerse electrode in calibration medium and wait until the ORP value has stabilized. Enter the nominal ORP value (bottle).</p> <p><b>Be sure to observe the correct reference!</b> (as configured) Confirm with <b>"OK"</b>.</p>
	<div style="float: right;">200 mV 25.6 °C</div> <p>ORP adjustment</p> <p>Reference electrode Ag/AgCl,KCl 1m</p> <p>Temperature +25.5°C</p> <p>ORP input +200 mV</p> <p>ORP setpoint +220 mV</p> <p>Abort OK</p>	
	<div style="float: right;">220 mV 25.6 °C</div> <p>ORP adjustment</p> <p>Reference electrode Ag/AgCl,KCl 1m</p> <p>Temperature +25.5°C</p> <p>ORP input +200 mV</p> <p>ORP setpoint +220 mV</p> <p>Return End</p>	

#### Temperature dependence of commonly used reference systems measured against SHE

Temperature [°C]	Ag/AgCl/KCl 1 mol/l [ΔmV]	Ag/AgCl/KCl 3 mol/l [ΔmV]	Thalamid [ΔmV]	Mercury sulfate [ΔmV]
0	249	224	-559	672
10	244	217	-564	664
20	240	211	-569	655
25	236	207	-571	651
30	233	203	-574	647
40	227	196	-580	639
50	221	188	-585	631
60	214	180	-592	623
70	207	172	-598	613
80	200	163	-605	603

# Calibration / Adjustment

---

## ISFET Zero Adjustment

### **ISFET Zero Adjustment**











When measuring with an ISFET sensor (Durafet, InPro 3300), the nominal zero point must be adjusted each time a new sensor is connected (to adjust the operating point). The adjustment for that sensor remains stored in the analyzer.

Afterwards, you should perform a two-point calibration using one of the following methods:

- Calimatic: automatic calibration
- Manual: entry of buffer values
- Data entry: premeasured electrodes

### **During calibration the module is in HOLD mode.**

Current outputs and relay contacts of the module behave as configured (BASE module).

Menu	Display	ISFET zero adjustment
 <b>cal</b>	  <span style="float: right;">7.00 pH 25.6°C</span> <hr/> <b>ISFET zero adjustment</b> <hr/>  Dip sensor in buffer solution! Enter temperature-corrected pH in the range pH 6.5...7.5 then "Start" calibration. Enter cal temp                   +025.6°C Buffer                               +07.00 pH <hr/> Return <b>Start</b> ←	<p>Immerse sensor in a zero point buffer (6.5 ... 7.5).  Enter temperature-corrected pH value (see buffer table).  Start zero adjustment.</p>
	  <span style="float: right;">7.00 pH 25.6°C</span> <hr/> <b>ISFET zero adjustment</b> <hr/>  Drift check running! Zero correction Electrode voltage               122 mV <b>Calibration temperature</b> 25.6 °C Nominal buffer value         7.00 pH Response time                 10 s <hr/> End	<p>To abort, you can press the "End" softkey. However, this reduces adjustment accuracy.  (Zero error of sensor up to max. ±200 mV possible)</p>
	  <span style="float: right;">7.00 pH 25.6°C</span> <hr/> <b>Calibration data record</b> <hr/>  Active adjustment   31.03.07 09:20 Cal mode                    ISFET zero ISFET zero                 +0122 mV Response time             0070 sec <hr/> End ←	<p>At the end of the adjustment procedure the ISFET zero (based on 25 °C) is displayed. This is not the real sensor value!  The actual values must be determined afterwards by a complete two-point calibration.</p>

# Parameter Setting: Operating Levels

Viewing level, Operator level, Administrator level

**Note:** HOLD mode (Setting: BASE module)

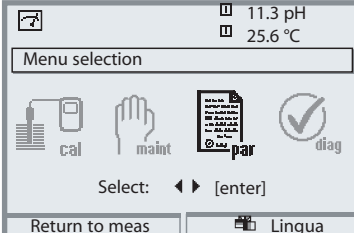
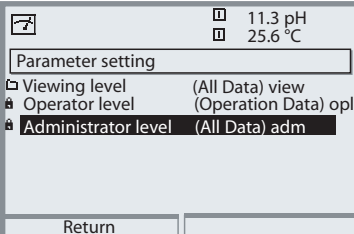
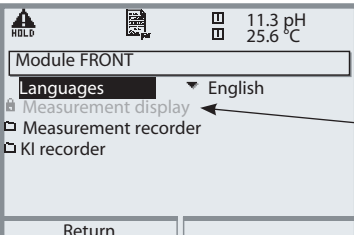

Menu	Display	Viewing level, Operator level, Administrator level
		<p><b>Call up parameter setting</b></p> <p>From the measuring mode: Press <b>menu</b> key to select menu. Select parameter setting using arrow keys, confirm with <b>enter</b>.</p>
		<p><b>Administrator level</b></p> <p>Access to all functions, also passcode setting. Releasing or blocking a function for access from the Operator level.</p> <p>Functions which can be blocked for the Operator level are marked with the "lock" symbol. The functions are released or blocked using the softkey.</p>
		<p><b>Operator level</b></p> <p>Access to all functions which have been released at the Administrator level. Blocked functions are displayed in gray and cannot be edited (Fig.).</p> <p><b>Viewing level</b></p> <p>Display of all settings. No editing possible!</p>



# Parameter Setting: Lock Functions

Administrator level: Enable / lock functions for Operator level

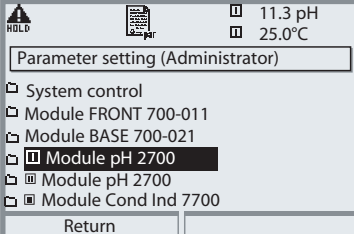
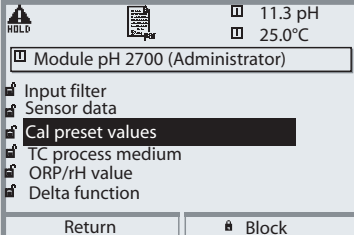
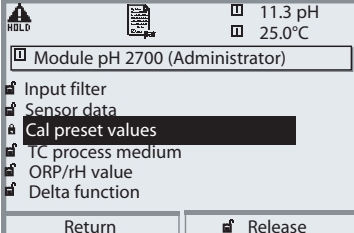
**Note:** HOLD mode (Setting: BASE module)

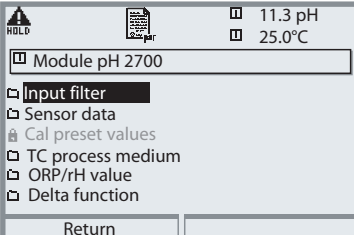
Menu	Display	Administrator level: Enable / lock functions
		<p><b>Example:</b> Blocking access to the calibration adjustments from the Operator level</p> <p><b>Call up parameter setting</b> Select Administrator level. Enter passcode (1989). Select "Module pH" (e.g.) using arrow keys, confirm with <b>enter</b>.</p>
		<p>Select "Cal preset values" using arrow keys. "Block" with softkey.</p>
		<p>Now, the "Cal preset values" line is marked with the "lock" icon. This function cannot be accessed from the Operator level any more. The softkey function changes to "Release".</p>
		<p><b>Call up parameter setting</b> Select <u>Operator level</u>, passcode (1246). Select "Module pH" (e.g.). Now, the locked function is displayed in gray and marked with the "lock" icon.</p>

# Activating Parameter Setting

Call up parameter setting

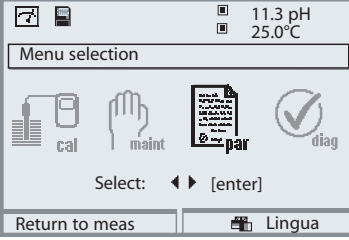
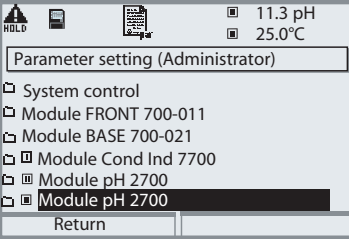
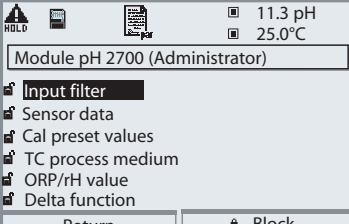
Menu	Display	Parameter setting
		<p><b>Call up parameter setting</b></p> <p>From the measuring mode: Press <b>menu</b> key to select menu. Select parameter setting using arrow keys, confirm with <b>enter</b>. Passcode as delivered: 1989</p>
		<p>Select module, confirm with <b>enter</b>.</p> <p>(In the Figure, the Module "pH" is selected, for example.)</p>
		<p>Select parameter using arrow keys, confirm with <b>enter</b>.</p>

**During parameter setting the analyzer is in HOLD mode:**

Current outputs and relay contacts behave as configured (BASE module).

# Documenting Parameter Setting

---

You must reproducibly document all parameter settings in the device to achieve a high level of system and device security according to GLP. For that purpose, an Excel file is provided (on the CD-ROM shipped with the basic device or as download at [www.mt.com/pro](http://www.mt.com/pro)) to enter the parameter settings.

The Excel file provides one worksheet for each module with columns for the following parameters: Factory settings, parameter set A, parameter set B. Enter your settings as parameter set A or B.

The gray cells in the parameter set B column cannot be modified since they contain sensor-specific values which cannot be changed by parameter set switchover. Here, the values listed under parameter set A apply.

# Documenting Parameter Setting

	A	B	C	D	E	F
1						
2	1.	<b>Meßstelle:</b>				Zugriff über Menüpunkt:
3		<b>M 700</b>				
4	1.1.	parametrier am / von:				
5						
6						
7	2.	<b>Gerätebeschreibung</b>	<b>Hardware</b>	<b>Software</b>	<b>Seriennummer</b>	Diagnose / Gerätebeschreibung
8	2.1.	Bedienfront 700-011 :				Diagnose / Gerätebeschreibung / Front
9	2.2.	M 700 Base 700-021:				Diagnose / Gerätebeschreibung / Base
10	2.3.	Modul Steckplatz [ I ] :				Diagnose / Gerätebeschreibung / I
11	2.4.	Modul Steckplatz [ II ] :				Diagnose / Gerätebeschreibung / II
12	2.5.	Modul Steckplatz [ III ] :				Diagnose / Gerätebeschreibung / III
13						
14						
15		<b>M 700 Front</b>				
16	3.	<b>M 700 Front Einstellungen</b>	<b>Werkseinstellung</b>	<b>Parametersatz A</b>	<b>Parametersatz B</b>	
17	3.1.	Sprache:	Deutsch			Parametrierung (Spezialist) / Modul Front ...
18						
19	3.1.1	Meßwertanzeige:				
20		Hauptanzeige	2 Hauptmeßwerte			Parametrierung (Spezialist) / Modul Front ... / Meß
21		1. Hauptmeßwert (Modul/Wert):	modulabhängig			
22		2. Hauptmeßwert (Modul/Wert):	modulabhängig			
23		Anzeigeformat (pH)	xx.xx pH			
24		Blickwinkel	Mitte			
25						
26	3.3.	Nebenanzeige				Einstellung erfolgt über Softkeys, wenn in Matrixfu
27		Anzeigewert, links	-			
28		Anzeigewert, rechts	-			
29						
30	3.4	Meßwertrecorder:	Option SW700-103			Parametrierung (Spezialist) / Modul Front ... / Meß
31		Zeitbasis (t / Pixel)	1 min			
32		Zeitlupe (10x)	Aus			
33		Min / Max anzeigen	Ein			
34	3.4.1	Kanal 1: Meßgröße	modulabhängig			
35		Anfang	0.00			
36		Ende	14.00			
37	3.4.2	Kanal 2: Meßgröße	modulabhängig			
38		Anfang	-50.0			
39		Ende	150.0			

From the application window of the Excel file, select the worksheet for the module the parameter settings of which you want to document. Set the parameters of the respective module and enter the selected values in the corresponding cells of the module worksheet.

## Caution!

<b>Display</b>	<b>During parameter setting the "HOLD" mode is active.</b>
	<p><b>HOLD.</b> The NAMUR "function check" contact is active (factory setting: Module BASE, Contact K2, N/O contact). Current output response is user-defined:</p> <ul style="list-style-type: none"> <li>• Current meas.: The currently measured value appears at the current output</li> <li>• Last usable value: The last measured value is held at the current output</li> <li>• Fixed 22 mA: The output current is at 22 mA</li> </ul>

# Settings of Sensor Data

With "Auto", the tolerance limits for the monitoring criteria are determined by the analyzer. They are displayed in gray.

With "Individual", these tolerances can be adjusted.

## Note:























HOLD mode active. Gray values (display) cannot be edited.

Parameter	Default	Selection / Range / Notes
Input filter		
• Pulse suppression	Off	Off, On (suppression of fast transients at the input)
Sensor data		
• Sensor type	Standard	Standard, ISFET, others
• Temperature detection		
Temperature probe	Pt 1000	Pt100, Pt1000, NTC30kohm (Sensor selection)
Measuring temp	Manual	Auto, manual: Default +25.0 °C (entry)
Cal temp	Manual	Auto, manual: Default +25.0 °C (entry)
• Sensoface	On	Off, On
• Sensor monitoring details		Monitoring: Auto, Individual
• Slope		Can only be set with "Sensor type Others" selected
Nominal	59.2 mV/pH	
Min	53.3 mV/pH	
Max	61.0 mV/pH	
Message	Maint. request	Off, Failure, Maint. request
• Zero		Monitoring: Auto, Individual
Nominal	07.00 pH	Can only be set with "Sensor type Others" selected
Min	06.00 pH	
Max	08.00 pH	
Message	Maint. request	Off, Failure, Maint. request
• Sensocheck Ref el		Monitoring: Auto, Individual
Nominal	5.0 kΩ	Can only be set with "Sensor type Others" selected
Min	3.1 kΩ	
Max	100.0 kΩ	
Message	Off	Off, Failure, Maint. request
• Sensocheck Glass el		Monitoring: Auto, Individual (not for ISFET)
Nominal	120.0 MΩ	Can only be set with "Sensor type Others" selected
Min	28.6 MΩ	
Max	350.0 MΩ	
Message	Off	Off, Failure, Maint. request
• Response time		Monitoring: Auto, Individual
Response time Max	0000 sec	
Message	Off	Off, Failure, Maint. request
• Calcheck		Monitoring: Auto, Individual
Meas distance max:	3.20 pH	
Message	Off	Off, Failure, Maint. request

# Settings of Sensor Data

Sensor data. pH sensor monitoring adjustable

**Note:** HOLD mode active

Menu	Display	Parameter selection
	  <div style="float: right;"> <input type="checkbox"/> 7.00 pH  <input type="checkbox"/> 20.1 °C         </div> <hr/> Module pH 2700 (Administrator) <ul style="list-style-type: none"> <li> Input filter</li> <li> <b>Sensor data</b></li> <li> Cal preset values</li> <li> TC process medium</li> <li> ORP/rH value</li> <li> Delta function</li> </ul> <hr/> <div style="display: flex; justify-content: space-between;"> <span>Return</span> <span> Block</span> </div>	<p><b>Sensor data</b> (also see previous page)</p> <p>Sensor data are preset depending on the sensor type.</p> <p>Gray display lines cannot be edited.</p>
	  <div style="float: right;"> <input type="checkbox"/> 7.00 pH  <input type="checkbox"/> 20.1 °C         </div> <hr/> <input checked="" type="checkbox"/> Sensor data (Administrator) <ul style="list-style-type: none"> <li>Sensor type <span style="float: right;">Standard</span></li> <li><input type="checkbox"/> Temperature detection (Pt100)</li> <li><b>Sensoface</b> <span style="float: right;"><input checked="" type="checkbox"/> On <input type="checkbox"/> Off</span></li> <li><input type="checkbox"/> Sensor monitoring details</li> </ul> <hr/> <div style="display: flex; justify-content: space-between;"> <span>Abort</span> <span>OK</span> </div>	<p><b>Sensoface</b> provides information on the sensor condition (evaluating the sensor data). Great deviations are signaled. Sensoface can be switched off.</p>
	  <div style="float: right;"> <input type="checkbox"/> 7.00 pH  <input type="checkbox"/> 20.1 °C         </div> <hr/> Sensor monitoring details (Administrator) <ul style="list-style-type: none"> <li> Slope (Auto)</li> <li> Zero (Auto)</li> <li> <b>Sensocheck Ref el</b> (Auto)</li> <li> Sensocheck Glass el (Auto)</li> <li> Response time (Auto)</li> <li> Calcheck (Individual)</li> </ul> <hr/> <div style="display: flex; justify-content: space-between;"> <span>Return</span> </div>	<p><b>Sensor monitoring details</b></p> <p>The following parameters are monitored: Slope, zero, reference impedance, glass impedance (pH electrodes), response time, CalCheck. For "Auto", the tolerance limits are displayed in gray. For "Individual", the settings can be specified by the user.</p>
	  <div style="float: right;"> <input type="checkbox"/> 7.00 pH  <input type="checkbox"/> 20.1 °C         </div> <hr/> <input checked="" type="checkbox"/> Sensocheck Ref el (Administrator) <ul style="list-style-type: none"> <li>Monitoring <span style="float: right;">▼ Auto</span></li> <li>Nominal <span style="float: right;">005.0 kΩ</span></li> <li>Min <span style="float: right;">003.1 kΩ</span></li> <li>Max <span style="float: right;">100.0 kΩ</span></li> <li><b>Message</b> <span style="float: right;">Off</span></li> </ul> <hr/> <div style="display: flex; justify-content: space-between;"> <span>Abort</span> <div style="border: 1px solid black; padding: 2px;"> <span>Failure</span>  <span>Maint.request</span> </div> </div>	<p><b>Message</b></p> <p>A message can be output as "Failure" (Module BASE, Contact K2) or "Maintenance request" (Module BASE, Contact K4). (Caution! Set contact parameters!)</p>

## Calcheck

Constantly checks distance between cal buffers and measured values.

# Sensoface

Graphical indication of sensor condition



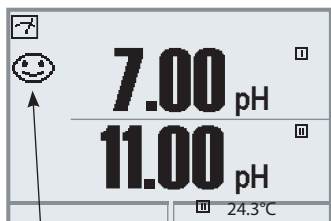





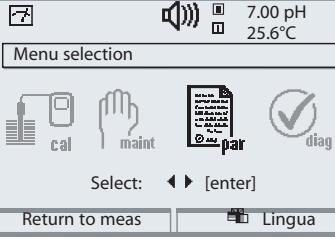

Sensocheck must have been activated during parameter setting



## Sensocheck

Automatic monitoring of glass and reference electrode

The "smileys" provide information on wear and required maintenance of the sensor ("friendly" - "neutral" - "sad").

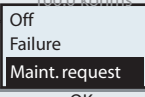
Menu	Display	Activate Sensocheck
	 <p>Select: ◀ ▶ [enter]</p> <p>Return to meas     Lingua</p> <p>  7.00 pH 25.6°C</p> <p> Parameter setting (Administrator)</p> <ul style="list-style-type: none"> <li>System control</li> <li>Module FRONT 700-011</li> <li>Module BASE 700-021</li> <li> Module O2 4700</li> <li> Module pH 2700</li> </ul> <p>Return</p> <p>  7.00 pH 25.6°C</p> <p> Sensocheck Ref el (Administrator)</p> <p>Nominal    005.0 kOhm Min        003.1 kOhm Max        100.0 kohms</p> <p>Message    </p> <p>Abort        OK</p>	<p><b>Open menu selection</b> Select parameter setting Enter passcode (Administrator)</p> <p>Select module ("pH"). Confirm with <b>enter</b></p> <p>Select "Sensor data". Confirm with <b>enter</b>. Then select "Sensocheck Ref el". (Fig.) Assign function and confirm with <b>enter</b>.</p>

# Sensoface is "sad" ...

The "Diagnostics / Module pH / Sensor network diagram" shows all current sensor parameters in a graphic diagram.

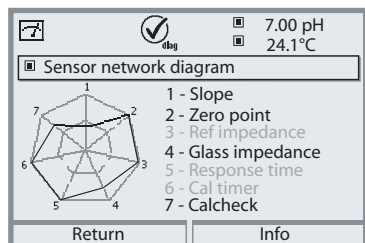

## Sensor network diagram

"Diagnostics / Module pH / Sensor network diagram".

Tolerance limit violations can be seen at a glance. Critical parameters (inner circle) are flashing. Parameters displayed in gray have been disabled during parameter setting or do not apply to the currently selected sensor.

## Sensoface Criteria

Parameter	Standard*	Critical range
Slope	59.2	< 53.3 or > 61
Zero	7.00	< 6,00 or > 8,00
Reference impedance	Rcal **	< 0.3 Rcal or > 3.5 Rcal
Glass impedance	Rcal **	< 0.6 Rcal or > 100 KΩ+ 0.5 Rcal
Response time Fine Standard Coarse		120 sec 80 sec 60 sec
Calibration timer		when 80 % expired
Calcheck		Difference meas. value / buffer > 3.2 pH

\* Applies to standard electrodes with pH = 7.00

\*\* Rcal is determined during calibration



# Parameter Setting: Cal Preset Values

Cal preset values

**Note:** HOLD mode active

Parameter	Default	Selection / Range
Cal preset values <ul style="list-style-type: none"> <li>Calimatic buffer</li> </ul>	Mettler-Toledo	Mettler-Toledo: 2.00 4.01 7.00 9.21 Merck/Riedel: 2.00 4.00 7.00 9.00 12.00 DIN 19267: 1.09 4.65 6.79 9.23 12.75 NIST standard: 4.006 6.865 9.180 NIST technical: 1.68 4.00 7.00 10.01 12.46 Hamilton A: 2.00 4.01 7.00 9.00 11.00 Hamilton B: 2.00 4.01 6.00 9.00 11.00 Kraft: 2.00 4.00 7.00 9.00 11.00
<ul style="list-style-type: none"> <li>Drift check</li> </ul>	Standard	Fine: 1.2 mV/min (Abort after 180 sec) Standard: 2.4 mV/min (Abort after 120 sec) Coarse: 3.75 mV/min (Abort after 90 sec)
<ul style="list-style-type: none"> <li>Cal timer               <ul style="list-style-type: none"> <li>Monitoring</li> <li>Calibration timer</li> <li>Adaptive cal timer</li> </ul> </li> </ul>	Auto 0000h (Off) Off	Auto Off, entry Off, On
<ul style="list-style-type: none"> <li>Tolerance band check (SW 700-005)</li> </ul>	Off	Tolerance adjustment: Off, On Tolerance band zero +00.20 pH (entry) Tolerance band slope +002.0 mV/pH (entry)

## Tolerance adjustment

(additional function SW 700-005)

During calibration this function checks the zero and slope values and automatically performs an adjustment when the tolerance band is exceeded. The parameters are stored in the tolerance band recorder (Diagnostics menu).

The additional function SW 700-005 is device-specific. When ordering the additional function, you therefore have to specify the serial number of your M 700 FRONT in addition to the respective order number.

(The M 700 FRONT contains the M 700 system control).

The manufacturer then supplies a TAN (transaction number) to release the additional function in the system control menu.

# SW 700-005: Tolerance Adjustment: Program Flow

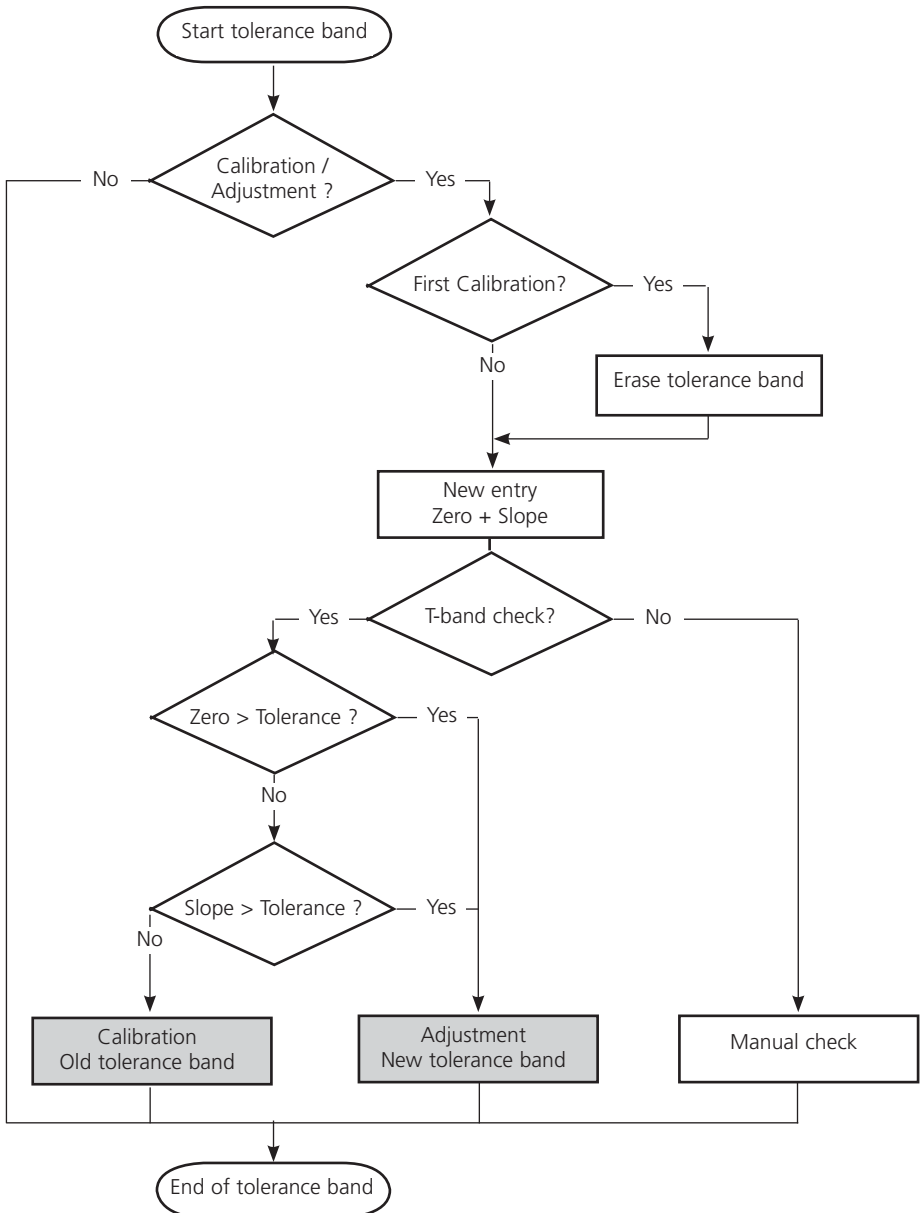

# Activating the Tolerance Adjustment

Select menu: Parameter setting/System control/Release of options

**Note:** The TAN for releasing an additional function is only valid for the device with the corresponding serial number!

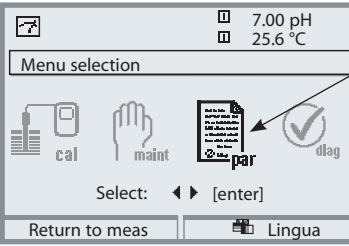
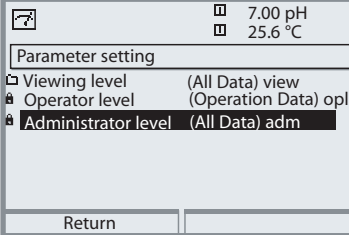
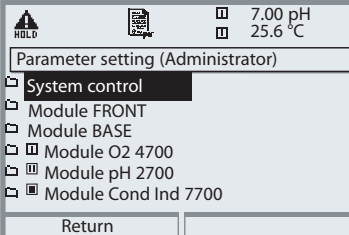
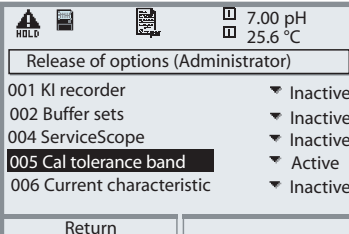
Menu	Display	Activate additional function
	 <p>The screenshot shows the 'Menu selection' screen. At the top, it displays '7.00 pH' and '25.6 °C'. Below that, there are four icons: 'cal', 'maint', 'par', and 'diag'. The 'par' icon is highlighted with a checkmark and an arrow pointing to it from the text on the right. Below the icons, it says 'Select: ◀ ▶ [enter]'. At the bottom, there are two buttons: 'Return to meas' and 'Lingua'.</p>	<p><b>Menu selection</b>            Call up parameter setting.            From the measuring mode:            Press <b>menu</b> key to select menu.            Select parameter setting using arrow keys, confirm with <b>enter</b>.</p>
	 <p>The screenshot shows the 'Parameter setting' screen. At the top, it displays '7.00 pH' and '25.6 °C'. Below that, there are three options: 'Viewing level (All Data) view', 'Operator level (Operation Data) opl', and 'Administrator level (All Data) adm'. The 'Administrator level' option is highlighted. At the bottom, there is a 'Return' button.</p>	<p><b>Parameter setting</b>            Select Administrator level using arrow keys confirm with <b>enter</b>.            Enter passcode and confirm (Passcode as delivered: 1989).</p>
	 <p>The screenshot shows the 'Parameter setting (Administrator)' screen. At the top, it displays '7.00 pH' and '25.6 °C'. Below that, there are four options: 'Module FRONT', 'Module BASE', 'Module O2 4700', and 'Module pH 2700'. The 'Module pH 2700' option is highlighted. At the bottom, there is a 'Return' button.</p>	<p>Select system control using arrow keys, confirm with <b>enter</b>.            Then select Release of options using arrow keys, confirm with <b>enter</b>.</p>
	 <p>The screenshot shows the 'Release of options (Administrator)' screen. At the top, it displays '7.00 pH' and '25.6 °C'. Below that, there are six options: '001 KI recorder', '002 Buffer sets', '004 ServiceScope', '005 Cal tolerance band', and '006 Current characteristic'. The '005 Cal tolerance band' option is highlighted. At the bottom, there is a 'Return' button.</p>	<p><b>Release of options</b>            Select the additional function to be released ("Cal tolerance band"). Set option to "active". Enter the TAN at the prompt. (Note: The TAN is only valid for the device with the corresponding serial number, see page 57.) The option is available after the TAN has been entered.</p>

# Parameter Setting: Cal Preset Values

Cal preset values: Calimatic buffer, Cal timer, Cal tolerance band

**Note:** HOLD mode active

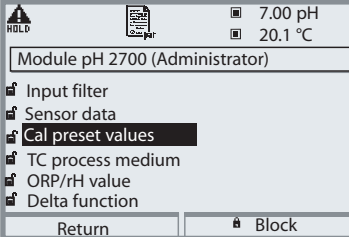
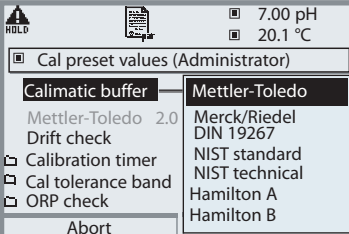
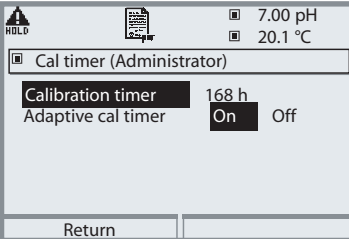
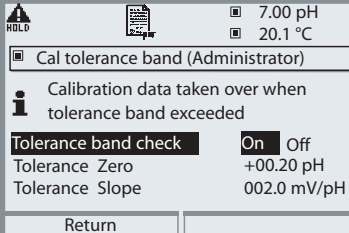
Menu	Display	Cal preset values
		<h3>Calimatic buffer</h3> <p>For automatic calibration, you must define the buffer set you want to use. For calibration, you must then use buffer solutions from this buffer set in any order.</p> <p>The selected buffer set with the nominal values of the individual buffer solutions is displayed in gray.</p> <p>The “Calimatic buffer” menu shows all buffer sets available.</p> <p>Select buffer set with <b>enter</b>.</p>
		<h3>Calibration timer</h3> <p>Entry of the time interval until the next due calibration.</p> <h3>Adaptive cal timer</h3> <p>Automatically reduces the time until the next due calibration when the electrode is exposed to high stress (temperature, extreme pH values).</p>
		<h3>Cal tolerance band</h3> <p>If the measured value leaves the tolerance band specified here for zero and slope, an adjustment is automatically performed during calibration.</p>
		

# Parameter Setting

Default settings and selection range

**Note:** HOLD mode active

Parameter	Default	Selection / Range
TC process medium • TC correction	Off	Off, linear, ultrapure water, table, Linear: enter temperature factor +XX.XX %/K
ORP/rH value • Reference electrode  • ORP conversion to SHE • Calculate rH with factor	Ag/AgCl,KCl 1mol/l  No No	Ag/AgCl,KCl 3mol/l Hg, Tl/TlCl, KCl 3.3 mol/l Hg/Hg <sub>2</sub> SO <sub>4</sub> , K <sub>2</sub> SO <sub>4</sub> sat No, Yes No, Yes, entry of factor
Delta function • Delta function	Off	Off, pH, mV+ORP or rH: entry of delta value

# Parameter Setting

TC process medium

**Note:** HOLD mode active

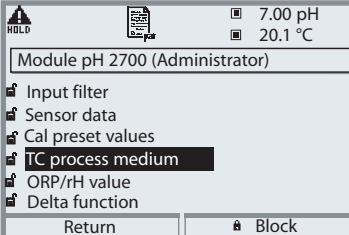
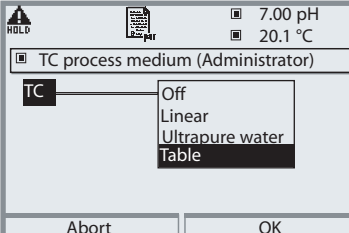
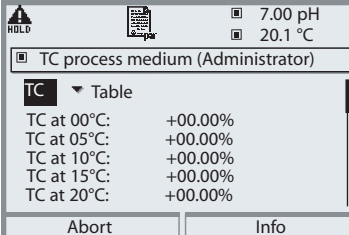
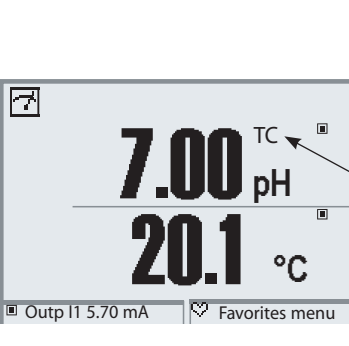
Menu	Display	TC process medium (Parameter selection Pg 61)
		<p><b>TC process medium</b></p> <p>You can choose from:</p> <ul style="list-style-type: none"> <li>• Linear (entry of TC coefficient)</li> <li>• Ultrapure water</li> <li>• Table</li> </ul>
		<p>When measuring media with a known temperature behavior, the output pH value can be corrected using a chart. TC can be entered in 5 °C steps for temperatures between 0 and +95 °C. Then, the output pH value is corrected by the corresponding TC value depending on the measuring temperature. Intermediate values are linearly interpolated. In the case of lower or higher temperatures (&lt; 0 °C or &gt; +95 °C), the last chart value is used for calculation. If the delta function has been activated (see Pg 61) simultaneously with temperature compensation, the temperature is compensated first and then the delta value is subtracted.</p>
		
		<p>When the TC correction for process medium is switched on, "TC" appears in the display in measuring mode.</p>

# Parameter Setting

---

TC process medium – Linear temperature compensation of process medium

## Temperature Compensation of Process Medium

Linear temperature compensation, reference temp fixed at 25 °C

$$\text{pH}(25\text{ °C}) = \text{pH}_M + \text{TC}/100 \% (25\text{ °C} - T_M)$$

$$\text{pH}(25\text{ °C}) = \text{pH value compensated to } 25\text{ °C}$$

$$\text{pH}_M = \text{Measured pH value (temperature-corrected)}$$

$$\text{TC} = \text{Temperature factor } [\%/K]$$

$$T_M = \text{Measured temperature } [^\circ\text{C}]$$

# Parameter Setting: ORP/rH Value

ORP/rH value, delta function

**Note:** HOLD mode active

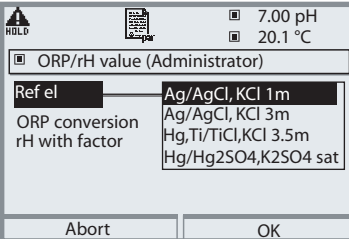
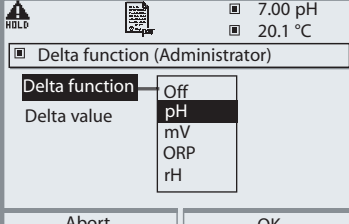
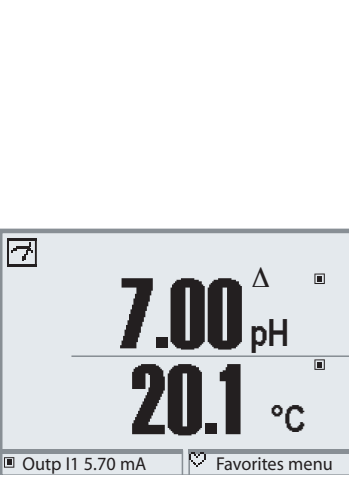
Menu	Display	ORP/rH value, Delta function (Selection Pg 61)
	 <p>ORP/rH value (Administrator)</p> <p>Ref el. <b>Ag/AgCl, KCl 1m</b></p> <p>ORP conversion rH with factor</p> <p>Ag/AgCl, KCl 3m Hg, Ti/TiCl, KCl 3.5m Hg/Hg<sub>2</sub>SO<sub>4</sub>, K<sub>2</sub>SO<sub>4</sub> sat</p> <p>Abort OK</p>	<p><b>ORP/rH value</b></p> <ul style="list-style-type: none"> <li>Select type of reference electrode:           <ul style="list-style-type: none"> <li>Ag/AgCl, KCl 1 mol/l (Silver/silver chloride)</li> <li>Ag/AgCl, KCl 3 mol/l (Silver/silver chloride)</li> <li>Hg, TI/TICl, KCl 3.3 mol/l (Thalamid)</li> <li>Hg/Hg<sub>2</sub>SO<sub>4</sub>, K<sub>2</sub>SO<sub>4</sub> saturated (mercury sulfate)</li> </ul> </li> <li>ORP conversion to SHE</li> <li>Calculate rH with factor</li> </ul>
	 <p>Delta function (Administrator)</p> <p>Delta function <b>Off</b></p> <p>Delta value <b>pH</b></p> <p>mV ORP rH</p> <p>Abort OK</p>	<p><b>Delta function</b></p> <p>When a delta value is entered, the system calculates the difference</p>
	 <p>7.00 <sup>Δ</sup> pH</p> <p>20.1 °C</p> <p>Outp I1 5.70 mA Favorites menu</p>	<p>Output value = measured value – delta value</p> <p>The output value controls all outputs and is shown on the display. When the delta function has been activated simultaneously with temperature compensation, the temperature is compensated first and then the delta value is subtracted. When delta function is switched on, “Δ” appears in the display in measuring mode.</p>



# Calculation Blocks

Select menu: Parameter setting/System control/Calculation Blocks  
Calculation of new variables from measured variables

## Calculation Blocks

Two measuring modules with all their measured values serve as input for the calculation block. In addition, the general device status (NAMUR signals) is taken into account. The difference between the existing values is calculated:

## Current Outputs

All current outputs can be set to output the new process variables formed by the Calculation Blocks.

## Measurement Display

All new process variables can be displayed as primary or as secondary value.

## Controller

Controller functions are not supported.

## Functionality of Measuring Module

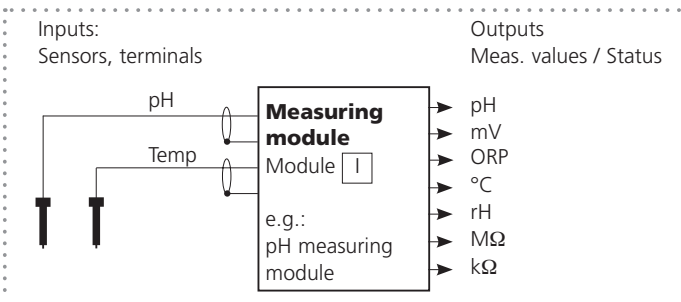

## Functionality of Calculation Block

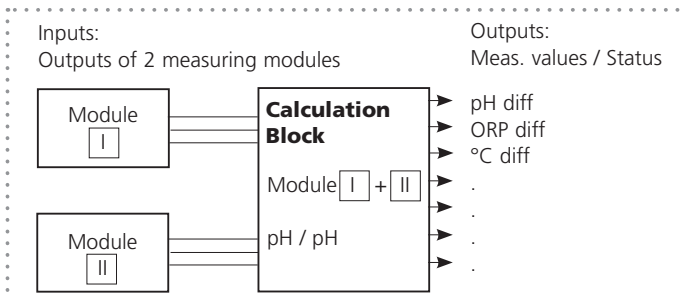

# Activating Calculation Blocks

Select menu: Parameter setting/System control/Calculation Blocks  
 Combining measuring modules to Calculation Blocks

## Combining Measuring Modules

With three measuring modules the following Calculation Block combinations are possible:  +  ,  +  ,  + 

Two Calculation Blocks can be activated.

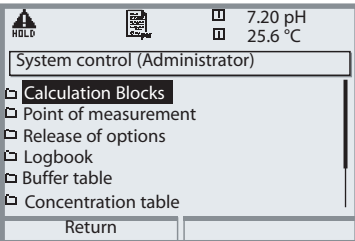
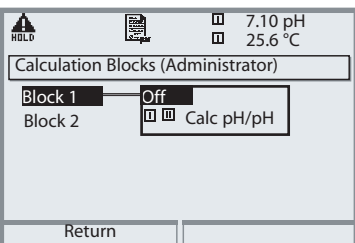
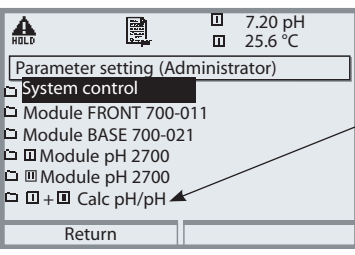
Menu	Display	Activating Calculation Blocks
		<p><b>Calculation Blocks</b></p> <ul style="list-style-type: none"> <li>• Call up parameter setting</li> <li>• System control</li> <li>• Select "Calculation Blocks"</li> </ul>
		<ul style="list-style-type: none"> <li>• Depending on the modules installed, the possible combinations for Calculation Blocks are offered.</li> </ul>
		<p>During parameter setting the Calculation Blocks are displayed like modules.</p>

# Configuring a Calculation Block

Select menu: Parameter setting/System control/Calculation Blocks  
 Setting the process variable to be calculated

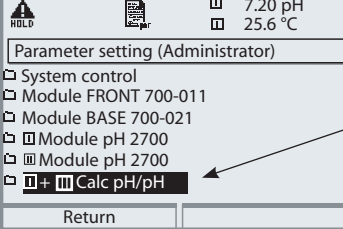
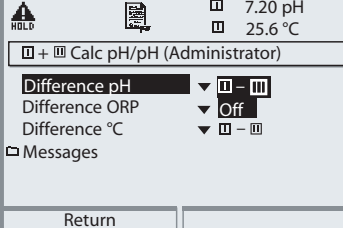
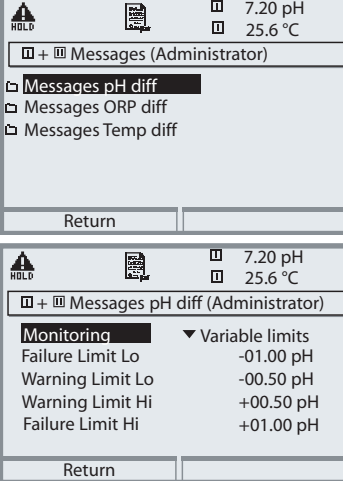
Menu	Display	Configuring a Calculation Block
		<p><b>Select Calculation Block</b></p> <ul style="list-style-type: none"> <li>• Call up parameter setting</li> <li>• System control</li> <li>• Select module</li> </ul>
		<ul style="list-style-type: none"> <li>• Depending on the modules installed, the possible combinations for Calculation Blocks are offered.</li> </ul>
		<p><b>Messages</b></p> <p>You can activate messages for the selected variables.</p> <p>Variables which have been set as "Off" cannot be processed further.</p> <p>The measured values which shall release a message are set using the arrow keys (left/right: select position, up/down: edit number) and confirmed with <b>enter</b>.</p>

# Logbook, Factory Setting

Parameter setting/System control/Logbook

**Note:** HOLD mode

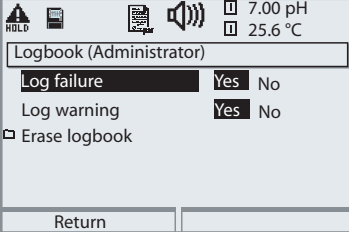
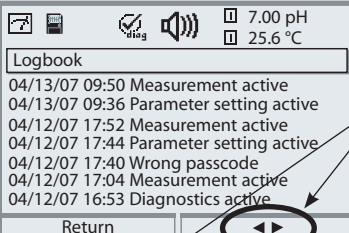
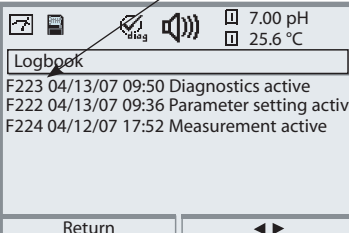
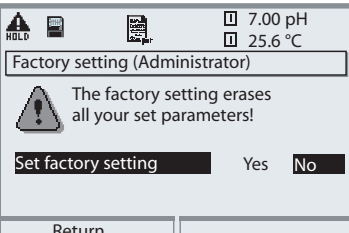
Menu	Display	Logbook, Factory setting
	   	<p><b>Logbook</b></p> <p>Select which messages are to be logged in the logbook. The last 50 events are recorded with date and time. This permits quality management documentation to ISO 9000 et seq.</p> <p>The logbook can be called up from the diagnostics menu (Fig.). Pressing the right softkey displays the message identifier.</p> <p>Additional function SW 700-104: Extended logbook for recording data on SmartMedia card (TAN).</p> <p><b>Factory setting</b></p> <p>Allows resetting the parameters to their factory setting. When this menu is opened, the analyzer displays a warning (Fig.).</p>

# Parameter Setting

Messages: Default settings and selection range

**Note:** HOLD mode active

Parameter	Default	Selection / Range
Messages <ul style="list-style-type: none"> <li>• pH value</li> <li>• ORP value</li> <li>• rH value</li> <li>• Temperature</li> <li>• mV value</li> </ul>	Limits max Off Off Limits max Off	Off, device limits max., variable limits* Off, device limits max., variable limits* Off, device limits max., variable limits* Off, device limits max., variable limits* Off, device limits max., variable limits*  * With "Variable limits" selected, the following parameters can be edited: <ul style="list-style-type: none"> <li>• Failure Limit Lo</li> <li>• Warning Limit Lo</li> <li>• Warning Limit Hi</li> <li>• Failure Limit Hi</li> </ul>

## Device Limits



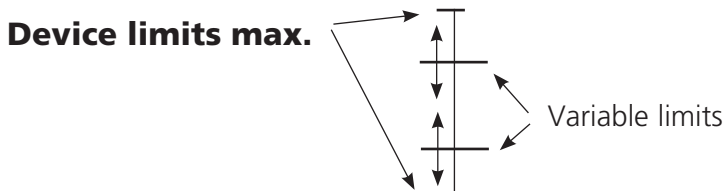

- Device limits max.    Maximum measurement range of device
- Variable limits:    Range limits specified

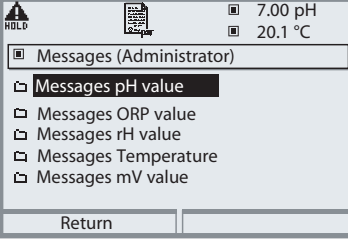
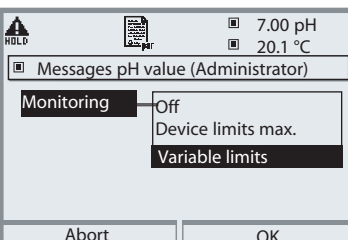
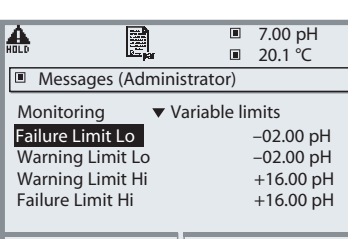

# Setting the Message Parameters

Messages

**Note:** HOLD mode active

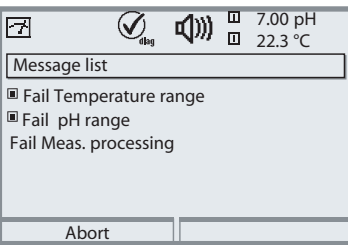
Menu	Display	Messages
	  	<h2>Messages</h2> <p>All parameters determined by the measuring module can generate messages.</p> <ul style="list-style-type: none"> <li> <b>Device limits max:</b>            Messages are generated when the process variable (e.g. pH) is outside the measurement range. The "Failure" icon is displayed, the NAMUR failure contact is activated (BASE module, factory setting: contact K4, N/C contact). The current outputs can signal a 22 mA message (user defined).         </li> <li> <b>Variable limits:</b>            For the "failure" and "warning" messages you can define upper and lower limits for message generation.         </li> <li> <b>Message icons:</b>   Failure (Failure limit HiHi/LoLo)   Maintenance (Warning limit Hi/Lo)         </li> </ul>
		<h2>Diagnostics menu</h2> <p>When the "Maintenance" or "Failure" icons are flashing in the display, you should call up the Diagnostics menu. The messages are displayed in the "Message list".</p>

# Current Outputs, Contacts, OK Inputs

Select menu: Parameter setting/Module BASE

**Note:** HOLD mode active

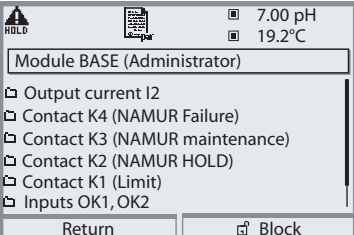
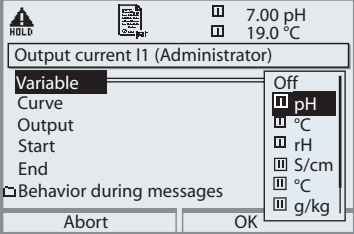
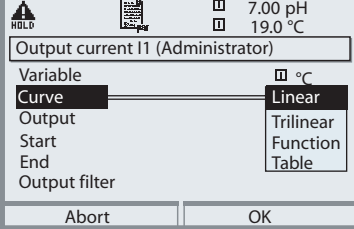
Menu	Display	Parameter setting BASE module
		<p>To configure current output</p> <ul style="list-style-type: none"> <li>• Call up parameter setting</li> <li>• Enter passcode</li> <li>• Select "Module BASE"</li> <li>• Select "Output current ..."</li> </ul>
		<ul style="list-style-type: none"> <li>• Select measured variable</li> </ul>
		<ul style="list-style-type: none"> <li>• Select Curve, e.g. "linear": The measured variable is represented by a linear output current curve. The desired range of the measured variable is specified by the values for "Start" and "End".</li> </ul>

## Assignment of Measured Values: Start (4 mA) and End (20 mA)

Example 1: Range pH 0 - 14

Example 2: Range pH 5 - 7

Advantage: Higher resolution in range of interest

Output current [mA]

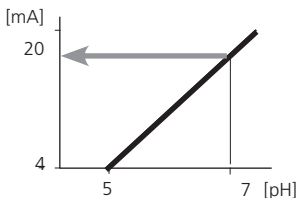
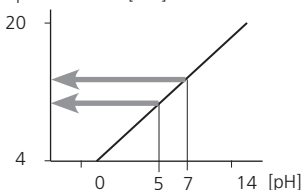

# Current Outputs: Characteristics

---

Select menu: Parameter setting/Module BASE

## • Linear characteristic

The measured variable is represented by a linear output current curve.

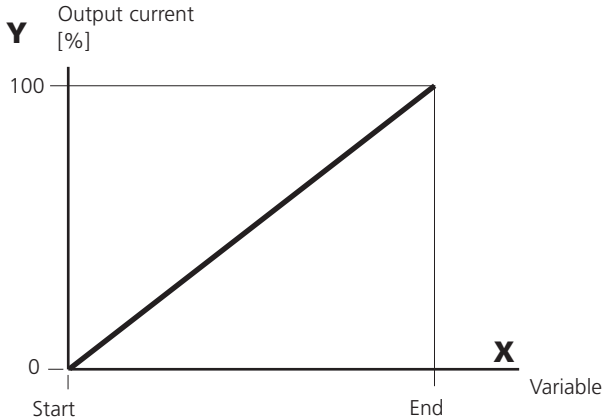

## • Trilinear characteristic

Two additional corner points must be entered:

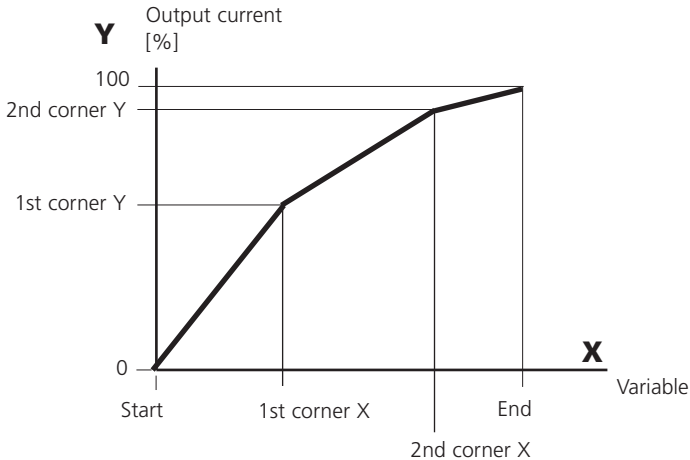

## • Note: Bilinear characteristic

For a bilinear characteristic, identical parameters are entered for the two corner points (1st corner, 2nd corner).



**• Function characteristic**

Nonlinear output current characteristic: allows measurements over several decades, e.g. measuring very low values with a high resolution and high values with a low resolution.

Required: Entering a value for 50 % output current.

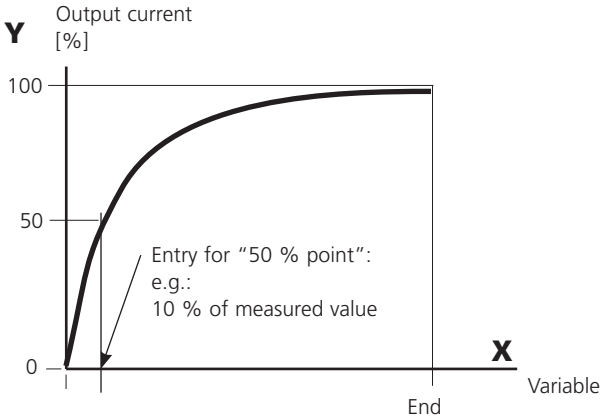

**Equation**

$$\text{Output current (4 ... 20 mA)} = \frac{(1+K)x}{1+Kx} \cdot 16 \text{ mA} + 4 \text{ mA}$$

$$K = \frac{E + S - 2 \cdot X50\%}{X50\% - S} \qquad x = \frac{M - S}{E - S}$$

- S: Start value at 4 mA
- X50%: 50% value at 12 mA (output current range 4 to 20 mA)
- E: End value at 20 mA
- M: Measured value

**Logarithmic output curve over one decade:**

- S: 10 % of maximum value
- X50%: 31.6 % of maximum value
- E: Maximum value

**Logarithmic output curve over two decades:**

- S: 1 % of maximum value
- X50%: 10 % of maximum value
- E: Maximum value

# Output Filter

---

## Time Constant

### Time Constant of Output Filter

To smoothen the current output, a low-pass filter with adjustable time constant can be switched on. When there is a jump at the input (100 %), the output level is at 63 % after the time constant has been reached.

The time constant can be set from 0 to 120 sec. If the time constant is set to 0 sec, the current output follows the input.

### Notice:

The filter only acts on the current output and the current value of the secondary display, not on the measurement display, the limit values, or the controller!

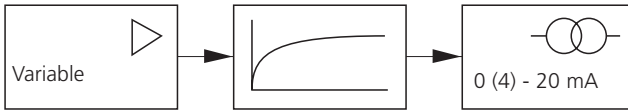

Time constant 0 to 120 sec

# NAMUR Signals: Current Outputs

Behavior during messages: HOLD, 22 mA signal

## Behavior During Messages

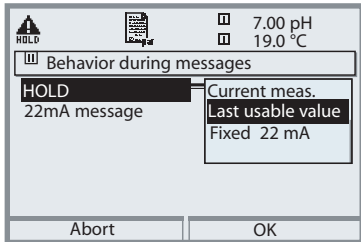

Depending on the parameter setting ("Messages") the current outputs switch to:

- Currently measured value
- Last measured value (HOLD function)
- Fixed value (22 mA)

In the case of a fault a 22 mA signal can be generated for the selected process variable (1st primary value).

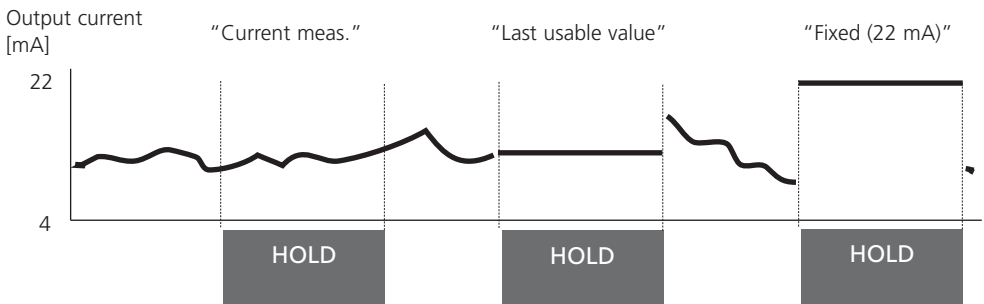

## Message when the Current Range is Exceeded

As delivered, the "Maintenance request" (Warn) message is generated when the current range is exceeded (< 3.8 mA or > 20.5 mA).

This setting can be changed in the Parameter setting menu of the respective measuring module at "Messages".

To generate a "Failure" message, the limit value monitoring must be set to "Variable limits":

Parameter setting - <measuring module> - Messages - Variable limits - Failure limit ...

Enter the same values for the failure limits as for the current output:

Parameter setting - Module BASE - Output current - Variable Start / End.

# NAMUR Signals: Relay Contacts

Failure, Maintenance Request, HOLD (Function Check)

As delivered, the floating relay outputs of the BASE module are assigned to the NAMUR signals:

<b>Failure</b>	Contact K4, normally closed (signaling current failure)
<b>Maint. request</b>	Contact K3, normally open contact
<b>HOLD</b>	Contact K2, normally open contact

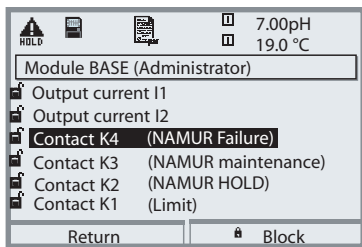

**NAMUR signals:** Factory setting of contacts

- Select parameter setting:
  - Administrator level
  - Select "Module BASE" (Fig.)
- You can define a delay time for "Maintenance request" and "Failure", resp. If an alarm message is released, the contact will only be activated after expiry of this delay time.

**Failure** is active

when a value has exceeded (or fallen below, resp.) a preset "Failure Limit Hi" or "Failure Limit Lo", when the measured value is out of range, or in the event of other failure messages. That means that the equipment no longer operates properly or that process parameters have reached a critical value. Failure is disabled during "HOLD" (function check).

**Maintenance request** is active

when a value has exceeded (or fallen below, resp.) a preset "Warning Limit Hi" or "Warning Limit Lo", or when other warning messages have been activated. That means that the equipment is still operating properly but should be serviced, or that process parameters have reached a value requiring intervention.

Failure is disabled during "HOLD" (function check).

**HOLD** is active:

- during calibration
- during maintenance (current source, meas. point maintenance)
- during parameter setting at the Operator level and the Administrator level
- during an automatic rinsing cycle.

# Relay Contacts: Protective Wiring

---

## Protective Wiring of Relay Contacts

Relay contacts are subjected to electrical erosion. Especially with inductive and capacitive loads, the service life of the contacts will be reduced. For suppression of sparks and arcing, components such as RC combinations, nonlinear resistors, series resistors and diodes should be used.

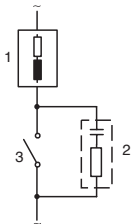
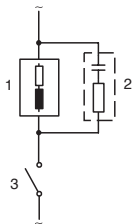

### Typical AC applications with inductive load

- 1 Load
- 2 RC combination, e.g. RIFA PMR 209  
Typical RC combinations  
e.g.  
Capacitor 0.1  $\mu$ F,  
Resistor 100 ohms / 1 W
- 3 Contact

## Caution!

Make sure that the maximum ratings of the relay contacts are not exceeded even during switching!

## Information Concerning Relay Contacts

As delivered, the relay contacts are suitable for low signal currents (down to approx. 1 mA). If currents above approx. 100 mA are switched, the gold plating is destroyed during the switching process. After that, the contacts will not reliably switch low currents.

# Relay Contacts

Parameter setting/Module BASE/Relay contacts

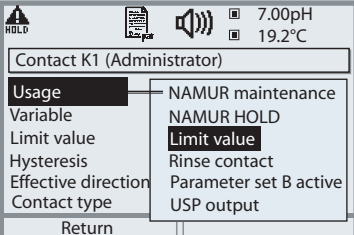
Menu	Display	Setting the relay contacts
		<p><b>Relay contacts, usage</b></p> <ul style="list-style-type: none"> <li>• Call up parameter setting</li> <li>• Enter passcode</li> <li>• Select "Module BASE"</li> <li>• Select "Contact ..."</li> <li>• "Usage" (Fig.)</li> </ul>

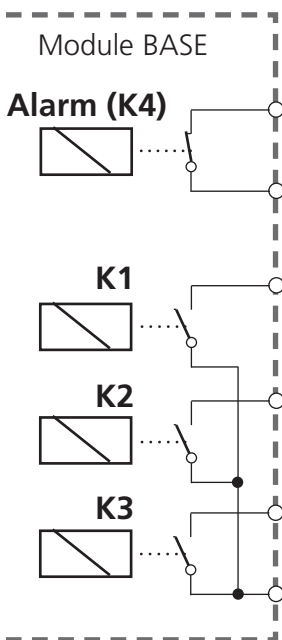

## Contact assignment:

See terminal plate of BASE module

The BASE module provides 4 relay contacts (max. AC/DC rating 30 V / 3 A each). Contact K4 is provided for failure message. The switching behavior (normally open or normally closed), as well as a switch-on or switch-off delay can be defined.

## Default settings of the user-definable relay contacts of the BASE module:

- K3: NAMUR maintenance request
- K2: NAMUR HOLD (function check)
- K1: Limit

## K1-K3 are user definable ("Usage"):

- NAMUR maintenance
- NAMUR HOLD
- Limit value
- Rinse contact
- Parameter set B active
- USP output (COND module only)
- KI rec. active
- Sensoface
- Controller alarm

# Rinse Contact

Parameter setting/Module BASE/Relay contacts/Usage/Rinse contact

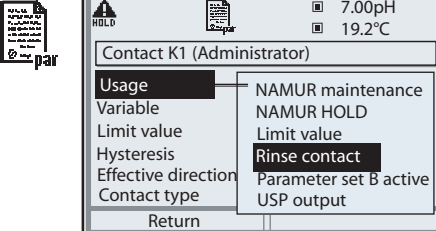
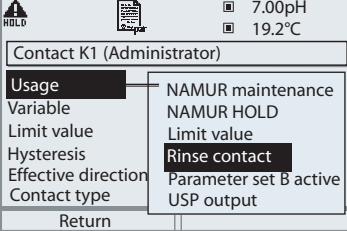
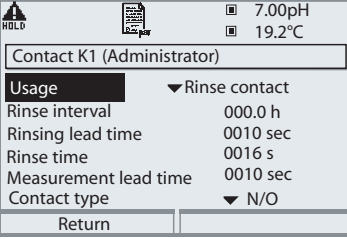
Menu	Display	Configuring the rinse contact
		<p><b>Relay contacts, usage</b></p> <ul style="list-style-type: none"> <li>• Call up parameter setting</li> <li>• Enter passcode</li> <li>• Select "Module BASE"</li> <li>• Select contact e.g. K1</li> <li>• "Rinse contact" (Fig.)</li> </ul>
		<p><b>Configuring the rinse contact</b></p> <ul style="list-style-type: none"> <li>• Set rinse interval</li> <li>• Set rinse duration</li> <li>• During the defined "lead time" the "HOLD" mode is active.</li> <li>• Select contact type (e.g. "N/O")</li> </ul>

**Please note when configuring the "Rinse contact" function**

- "HOLD" mode (e.g. during parameter setting) delays the execution of the "Rinse contact" function.
- Up to 3 rinse functions (contacts K1 ... K3) can be configured independently.
- The individual rinse functions are not synchronized with each other.

**Time Response**

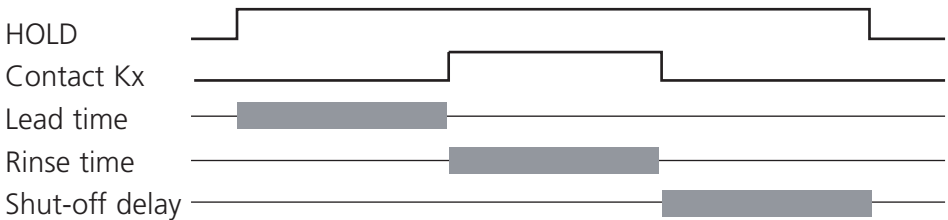

# Limit Value, Hysteresis, Contact Type

Parameter setting/Module BASE/Relay contacts/Usage

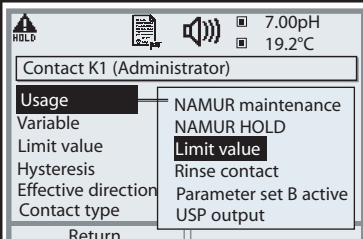
Menu	Display	Usage as limit value
		<b>Relay output: Limit</b> <ul style="list-style-type: none"> <li>• Call up parameter setting</li> <li>• Enter passcode</li> <li>• Select "Module BASE"</li> <li>• Select "Contact ..."</li> <li>• "Usage: Limit" (Fig.)</li> </ul>

## Limit value ▾

Effective direction min

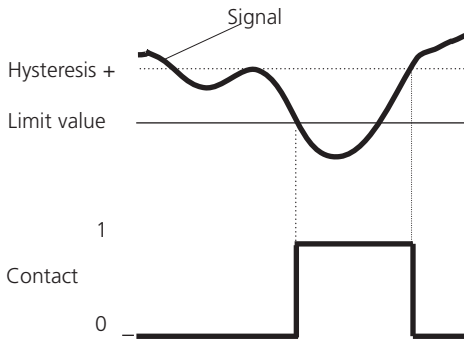

## Limit value ▲

Effective direction max

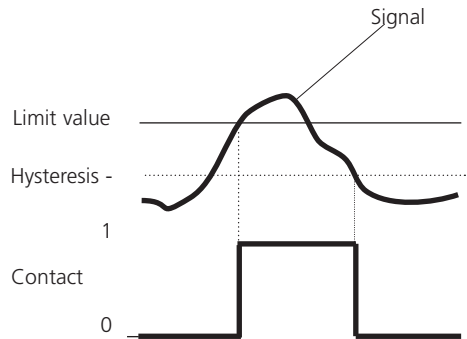

## Icons in the Measurement Display:

Measured value exceeds limit: ▲ Measured value falls below limit: ▾

## Hysteresis

Tolerance band around the limit value, within which the contact is not actuated. Serves to obtain appropriate switching behavior at the output and suppress slight fluctuations of the measured variable (Fig.)

## Contact Type



Specifies whether the active contact is closed (N/O) or open (N/C).



# OK1, OK2 Inputs: Specify Level

Parameter setting/Module BASE/Inputs OK1, OK2

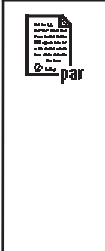
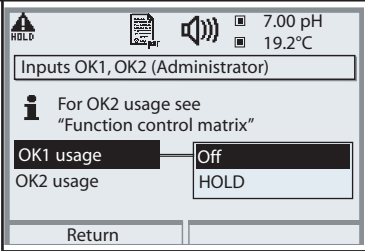
**Note:** HOLD mode (Setting: BASE module)

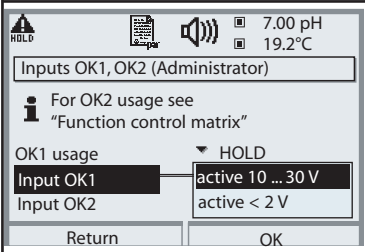
Menu	Display	Setting the OK inputs
		<p><b>OK1 usage</b></p> <ul style="list-style-type: none"> <li>• Call up parameter setting</li> <li>• Enter passcode</li> <li>• Select "Module BASE"</li> <li>• Select "Inputs OK1/OK2"</li> <li>• Select "OK1 usage"</li> </ul>
		<p><b>OK1/OK2 switching level</b></p> <ul style="list-style-type: none"> <li>• Call up parameter setting</li> <li>• Enter passcode</li> <li>• Select "Module BASE"</li> <li>• Select "Inputs OK1/OK2"</li> <li>• Specify active switching level</li> </ul>

The BASE module provides 2 digital inputs (OK1, OK2). The following functions (depending on the parameter setting) can be started via a control signal:

- OK1: "Off" or "HOLD" (Function check),
- OK2: Select: System control / Function control matrix ("Off", "Parameter set A/B", "Start KI recorder")

The switching level for the control signal must be specified:  
(active 10...30 V or active < 2 V).

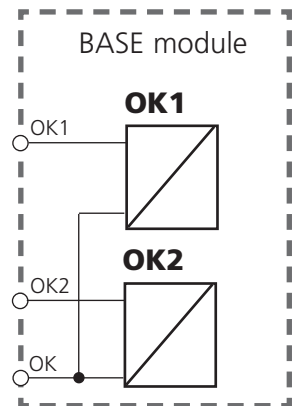

# Switching Parameter Sets via OK2

Parameter setting / System control / Function control matrix

**Note:** HOLD mode (Setting: BASE module)

## Parameter Sets

2 complete parameter sets (A, B) can be stored in the analyzer.

You can switch between the parameter sets using the OK2 input.

The currently activated set can be signaled by a relay contact.

An icon in the measurement display shows which parameter set is active:

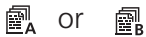

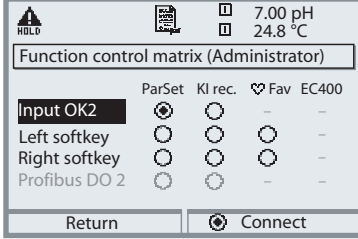
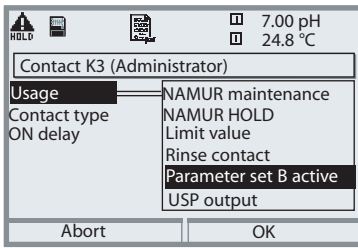
Menu	Display	Parameter sets
		<p><b>Select parameter set (A, B) via OK2 input</b></p> <ul style="list-style-type: none"> <li>• Call up parameter setting</li> <li>• System control</li> <li>• Function control matrix</li> <li>• Select “OK2”</li> <li>• Connect “Parameter set A/B”</li> </ul>
		<p><b>Signaling active parameter set via relay contact</b></p> <ul style="list-style-type: none"> <li>• Call up parameter setting</li> <li>• BASE module</li> <li>• Select contact</li> <li>• Usage: “Parameter set ...”.</li> </ul>

## Notice

The selection has no effect when working on SmartMedia card with SW 700-102.

# Maintenance

Sensor monitor, Temp probe adjustment

**Note:** HOLD mode active

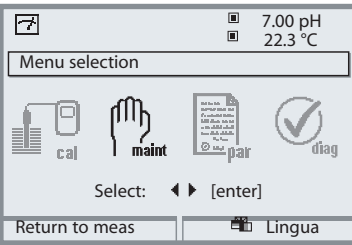
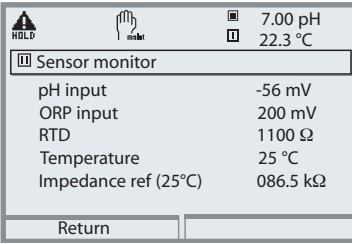
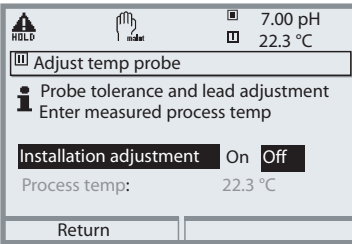
Menu	Display	Maintenance
	  	<h2>Call up Maintenance</h2> <p>From the measuring mode:            Press <b>menu</b> key to select menu.            Select maintenance using arrow keys,            confirm with <b>enter</b>.            Passcode as delivered: 2958            Then select "Module pH".</p> <h2>Sensor monitor</h2> <p>for validation of sensor and complete measured-value processing.</p> <h2>Temp probe adjustment</h2> <p>This function allows you to compensated for the individual temperature probe tolerance and the influence of the lead resistances to increase accuracy of temperature measurement. Adjustment may only be carried out when the process temperature is precisely measured using a calibrated reference thermometer! The measurement error of the reference thermometer should be less than 0.1 °C. Adjustment without precise measurement might result in considerable deviations of the measured value display!</p>

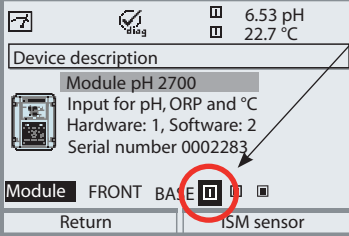
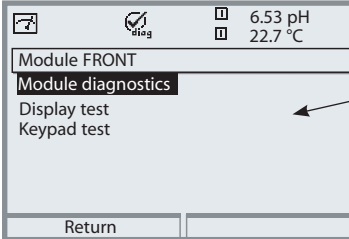
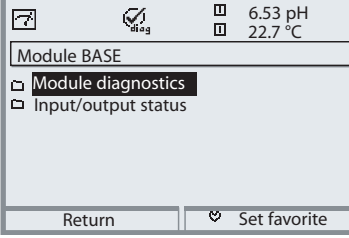
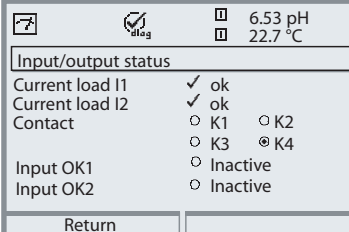

# Diagnostics Functions

Device description, FRONT module, BASE module

Menu	Display	Diagnostics functions
	 <p>The screenshot shows the 'Device description' menu. At the top, it displays '6.53 pH' and '22.7 °C'. Below this, it says 'Module pH 2700' and 'Input for pH, ORP and °C'. Further down, it lists 'Hardware: 1, Software: 2' and 'Serial number 0002283'. At the bottom, there is a 'Module' list with 'FRONT', 'BASE', and 'ISM sensor'. The 'BASE' option is circled in red, and an arrow points from the 'Device description' text in the adjacent column to this circled option.</p>	<p><b>Device description</b></p> <p>Select module using arrow keys: Provides information about all modules installed: Function, serial number, hardware and software version, and device options.</p>
	 <p>The screenshot shows the 'Module FRONT' diagnostics menu. It lists 'Module diagnostics', 'Display test', and 'Keypad test'. An arrow points from the 'FRONT module' text in the adjacent column to the 'Module diagnostics' option.</p>	<p><b>FRONT module</b></p> <p>The module contains the display and keypad control. Test possibilities:</p> <ul style="list-style-type: none"> <li>• Module diagnostics</li> <li>• Display test</li> <li>• Keypad test</li> </ul>
	 <p>The screenshot shows the 'Module BASE' diagnostics menu. It lists 'Module diagnostics' and 'Input/output status'. Below this, there is a 'Return' button and a 'Set favorite' button.</p>  <p>The screenshot shows the 'Input/output status' menu. It lists 'Current load I1', 'Current load I2', 'Contact', 'Input OK1', and 'Input OK2'. Each item has a status indicator: 'ok' (checked), 'K1', 'K2', 'K3', 'K4' (radio buttons), or 'Inactive'.</p>	<p><b>BASE module</b></p> <p>The module generates the standard output signals. Test possibilities:</p> <ul style="list-style-type: none"> <li>• Module diagnostics</li> <li>• Input/output status</li> </ul> <p>Example: Module BASE, input/output status.</p>

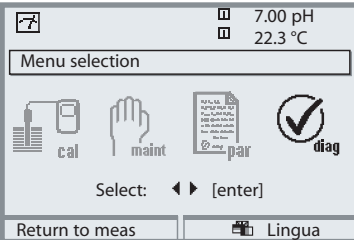

# Module Diagnostics

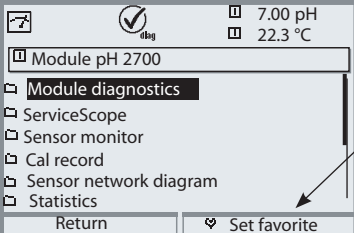
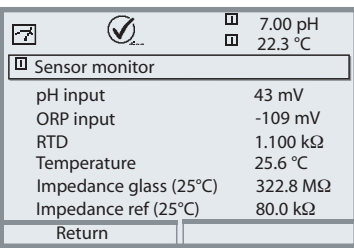
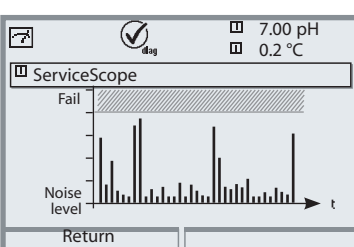
Module diagnostics / Sensor monitor / ServiceScope

Menu	Display	Module diagnostics / Sensor monitor / ServiceScope
		<p><b>Call up diagnostics</b></p> <p>From the measuring mode:            Press menu key: select menu.            Select diagnostics using arrow keys,            confirm with <b>enter</b>.            Then select "Module PH".</p>
		<p>The Diagnostics menu gives an overview of all diagnostics functions available. <u>Messages set as "Favorite"</u> can be called up directly from the measuring mode using a softkey. To configure:            Parameter setting / System control / Function control matrix.</p>
		<p><b>Module diagnostics</b></p> <p>Internal function test (without Fig.).</p> <p><b>Sensor monitor</b></p> <p>Shows the values currently measured by the sensor. Important function for diagnostics and validation!            (cf Maintenance)</p>
		<p><b>ServiceScope</b></p> <p>Monitors the pH input signal. Displays the noise levels over the time.            An error message is generated if the noise level exceeds the failure limit.</p>

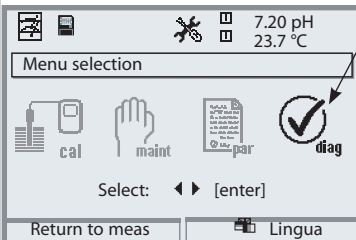

# Module Diagnostics

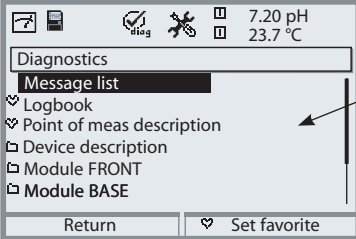
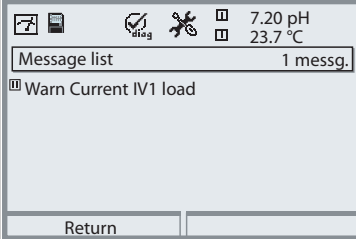
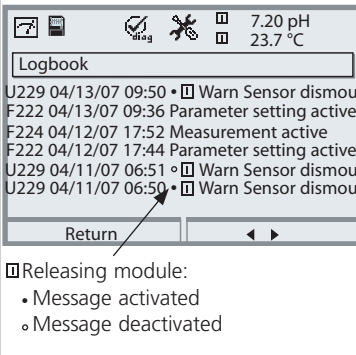
General status information of the measuring system  
 Select menu: Diagnostics

Menu	Display	Diagnostics functions
		<p><b>Call up diagnostics</b>        From the measuring mode:        Press <b>menu</b> key to select menu.        Select diagnostics using arrow keys,        confirm with <b>enter</b>.</p>
		<p>The “Diagnostics” menu gives an overview of all functions available. Functions which have been set as “Favorite” can be directly accessed from the measuring mode.</p>
		<p><b>Message list</b>        Shows the currently activated warning or failure messages in plain text.</p>
	 <p>◻ Releasing module:        • Message activated        ◦ Message deactivated</p>	<p><b>Logbook</b>        Shows the last 50 events with message identifier, date, time, module concerned, and plaintext of the message. This permits quality management documentation to ISO 9000 et seq.        Extended logbook: SmartMedia card (SW 700-104)</p>

# Module Diagnostics

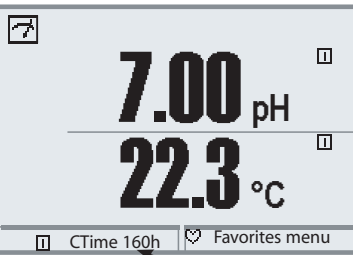
Cal timer, Adaptive cal timer, Tolerance adjustment

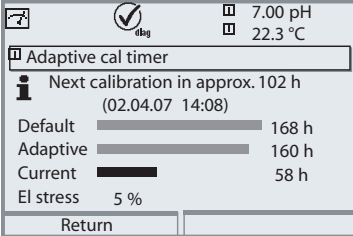
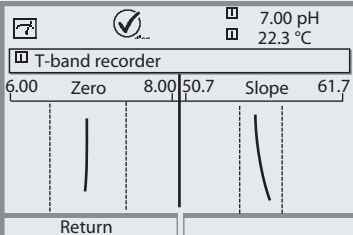
Menu	Display	Cal timer, Tolerance band recorder
		<p><b>Calibration timer</b></p> <p>After expiration of a presettable interval (Parameter setting, Module pH, Cal preset values), the calibration timer generates a warning message as a reminder that calibration is required. The remaining time can be indicated in the measuring mode by pressing a softkey (secondary display: "CTime").</p>
		<p><b>Adaptive calibration timer</b></p> <p>The time until the next due calibration is automatically reduced depending on the temperature and pH value, i.e. old electrode = timer expires sooner.</p>
		<p><b>Tolerance adjustment</b></p> <p>Additional function SW 700-005 Records the tolerance ranges for zero and slope over the time. If the values determined by a calibration exceed the tolerance limits, the calibration is taken over as adjustment. Display can be graphical or as a listing. The tolerance band (zero, slope) is configured during parameter setting (Module pH, Cal preset values).</p>

Menu	Display	Cal record, Sensor network diagram, Statistics
------	---------	--



7	diag	7.00pH	24.2°C
Cal record			
Active adjustment	03.04.07 15:35		
Sensor type	InPro3200SG		
Serial number	00150313		
Cal mode	Calimatic		
Zero	6.95 pH		
Slope	058.7 mV/pH		
Return	Calibration data		

**Cal record**  
 Data of last adjustment/calibration, suitable for documentation to ISO 9000 and GLP/GMP (Date, time, calibration method, zero and slope, isothermal potential, information concerning calibration buffers and response times)

7	diag	7.00pH	24.1°C
Sensor network diagram pH			
1 - Slope 2 - Zero point 3 - Ref impedance 4 - Glass impedance 5 - Response time 6 - Cal timer 7 - Sensor wear			
Return			

**Sensor network diagram**  
 Graphical representation of the sensor parameters. Tolerance limit violations can be seen at a glance. Critical parameters are flashing. Parameters displayed in gray have been disabled during parameter setting or do not apply to the currently selected sensor. The tolerance limits (radius of "inner circle") can be modified as desired. See Parameter setting / Sensor data / Sensor monitoring details.

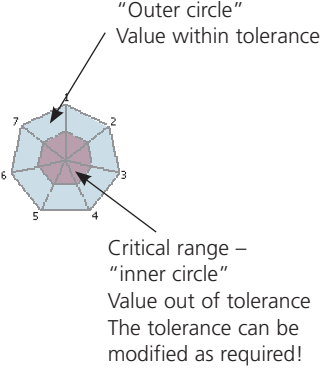

7	diag	7.00pH	20.2°C
Statistics			
Zero			
1st Cal	+07.00 pH 04/03/07 10:03		
Diff	+00.03 pH 04/03/07 17:24		
Diff	+00.02 pH 04/10/07 09:18		
Diff	+00.03 pH 04/11/07 10:47		
Slope			
Return			

**Statistics**  
 Indication of sensor data for the First Calibration (adjustment) and the last 3 calibrations compared to the First Calibration. (Date and time of First Calibration, zero and slope, impedance of glass and reference electrode, response time. For ISM, the data are stored in the sensor)



# Setting Diagnostics Messages as Favorite

Select menu: Parameter setting/System control/Function control matrix

## Secondary Displays (1)

Here, additional values are displayed in the measuring mode according to the factory setting. When the respective softkey (2) is pressed, the process variables measured by the modules plus date or time are displayed. In addition, you can use the **softkeys (2)** to control functions. To assign a function to a softkey, select

## Parameter setting/System control/ Function control matrix

Function which can be controlled by softkeys:

- Parameter set selection
- KI recorder Start/Stop
- Favorites
- EC400 (fully automated probe controller)

## Favorites

Selected Diagnostics functions can be called up directly from the measuring mode using a softkey. The table on the next page explains how to select favorites.

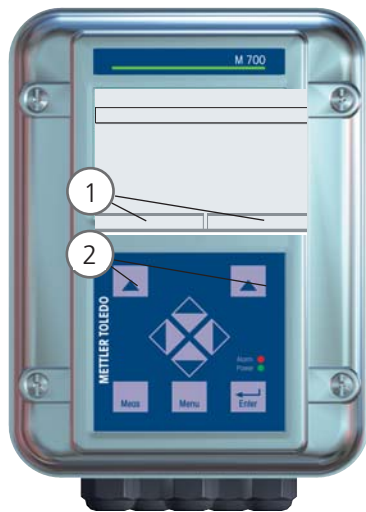



Function control matrix (Administrator)				
	ParSet	KI rec.	♥Fav	EC400
Input OK2	<input type="radio"/>	<input type="radio"/>	<input type="radio"/>	-
Left softkey	<input type="radio"/>	<input type="radio"/>	<input type="radio"/>	-
Right softkey	<input type="radio"/>	<input type="radio"/>	<input checked="" type="radio"/>	-
Profibus DO 2	<input type="radio"/>	<input type="radio"/>	<input type="radio"/>	-
Return		Connect		

Example:  
"Favorites" to be selected with  
"Right softkey"

To select a softkey function:  
Select desired function  
using arrow keys,  
press "Connect" softkey and  
confirm with **enter**.

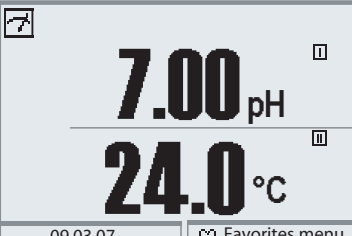
To deselect a function:  
Press "Disconnect" softkey,  
confirm with **enter**.

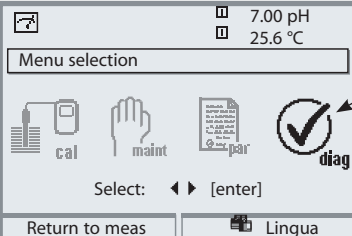
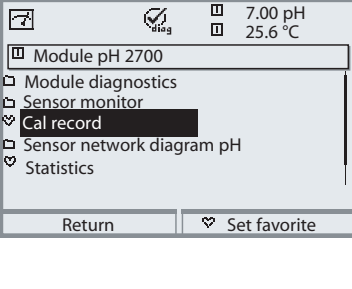
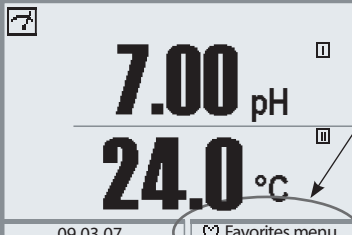
Menu	Display	Select favorites
		<p><b>Favorites menu</b></p> <p>Diagnostics functions can be called up directly from the measuring mode using a softkey.</p> <p>The "Favorites" are selected in the Diagnostics menu.</p>
		<p><b>Select favorites</b></p> <p>Press <b>menu</b> key to Menu selection</p> <p>Select diagnostics using arrow keys, confirm with <b>enter</b>. Then select module and confirm with <b>enter</b>.</p>
		<p>Set/delete favorite:</p> <p>"Set favorite" allows activation of the selected diagnostic function directly from the measuring mode via softkey.</p> <p>The menu line is marked with a heart icon.</p>
		<p>Pressing the <b>meas</b> key returns to measurement. When the softkey has been assigned to "Favorites", "Favorites menu" is read in the secondary display (see "Function control matrix").</p>

**Notice:**

When one of the softkeys has been assigned to the "Favorites menu" function, diagnostic functions which have been set as "Favorite" can be directly called up from the measuring mode.

# Diagnostics Functions

General status information of the measuring system  
 Select menu: Diagnostics - Message list

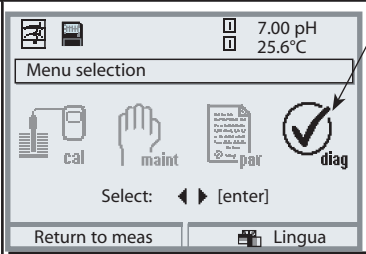
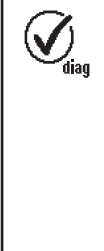
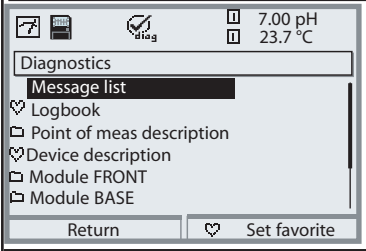
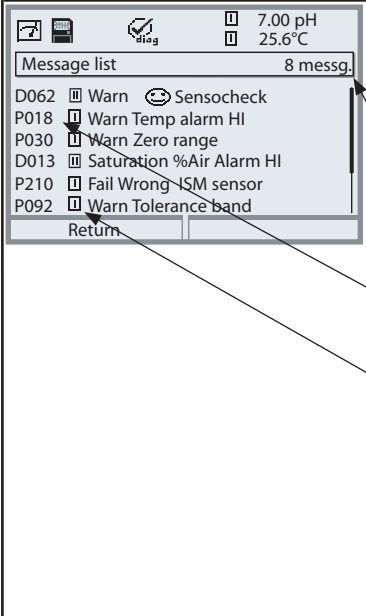
Menu	Display	Diagnostics functions
		<p><b>Call up diagnostics</b>        From the measuring mode:        Press <b>menu</b> key to select menu.        Select diagnostics using arrow keys,        confirm with <b>enter</b>.</p>
		<p>The “Diagnostics” menu gives an overview of all functions available. Functions which have been set as “Favorite” can be directly accessed from the measuring mode.</p>
		<p><b>Message list</b>        Shows the currently activated warning or failure messages in plain text.</p> <p><b>Number of messages</b>        When there are more than 7 messages, a vertical scrollbar appears. Scroll with the up/down arrow keys.</p> <p><b>Message identifier</b>        See message list for description.</p> <p><b>Module identifier</b>        Specifies the module that has generated the message.</p>

# Messages

---

## Messages pH 2700i(X) Module

No.	pH message	Message type
P008	Meas. processing (factory settings)	FAIL
P009	Module failure (Firmware Flash check sum)	FAIL
P010	pH range	FAIL
P011	pH Alarm LO_LO	FAIL
P012	pH Alarm LO	WARN
P013	pH Alarm HI	WARN
P014	pH Alarm HI_HI	FAIL
P015	Temperature range	FAIL
P016	Temperature Alarm LO_LO	FAIL
P017	Temperature Alarm LO	WARN
P018	Temperature Alarm HI	WARN
P019	Temperature Alarm HI_HI	FAIL
P020	ORP range	FAIL
P021	ORP Alarm LO_LO	FAIL
P022	ORP Alarm LO	WARN
P023	ORP Alarm HI	WARN
P024	ORP Alarm HI_HI	FAIL
P025	rH range	WARN
P026	rH Alarm LO_LO	FAIL
P027	rH Alarm LO	WARN
P028	rH Alarm HI	WARN
P029	rH Alarm HI_HI	FAIL
P030	Zero range	WARN
P035	Slope range	WARN
P040	Isotherm potential Uis range	WARN
P045	mV range	WARN

# Messages

---

<b>No.</b>	<b>pH message</b>	<b>Message type</b>
P046	mV Alarm LO_LO	FAIL
P047	mV Alarm LO	WARN
P048	mV Alarm HI	WARN
P049	mV Alarm HI_HI	FAIL
P050	Man. temperature range	FAIL
P060	SAD SENSOFACE: Slope	User-defined
P061	SAD SENSOFACE: Zero	User-defined
P062	SAD SENSOFACE: Ref impedance (Sensocheck)	User-defined
P063	SAD SENSOFACE: Glass impedance (Sensocheck)	User-defined
P064	SAD SENSOFACE: Response time	User-defined
P065	SAD SENSOFACE: Calibration timer	WARN
P066	SAD SENSOFACE: Calcheck	User-defined
P069	SAD SENSOFACE: Calimatic (Zero/slope)	WARN
P070	SAD SENSOFACE: Sensor wear	User-defined
P071	SAD SENSOFACE: ISFET leakage current	User-defined
P090	Buffer offset (buffer table to be entered):	WARN
P091	Zero offset ORP	WARN
P092	Tolerance band	WARN
P110	CIP counter	User-defined
P111	SIP counter	User-defined
P112	Autoclaving counter	User-defined
P113	Sensor operating time (duration of use)	User-defined
P114	ISFET characteristic	User-defined
P115	Membrane body changes	User-defined
P120	Wrong ISM sensor	FAIL
P121	ISM sensor (error in factory settings/characteristics)	FAIL
P122	ISM sensor memory (error in cal data records)	WARN
P123	New sensor, adjustment required	WARN
P130	SIP cycle counted	Text
P131	CIP cycle counted	Text

# Messages

---

No.	pH message	Message type
P200	Noise level at pH input	FAIL
P201	Cal temp	WARN
P202	Cal: Buffer unknown	Text
P203	Cal: Identical buffers	Text
P204	Cal: Buf interchanged	Text
P205	Cal: Sensor unstable	Text
P206	Cal: Slope	WARN
P207	Cal: Zero	WARN
P208	Cal: Sensor failure (ORP check)	FAIL
P254	Module reset	Text

No.	Calculation Block pH / pH messages	Message type
A010	pH-Diff Range	FAIL
A011	pH-Diff Alarm LO_LO	FAIL
A012	pH-Diff Alarm LO	WARN
A013	pH-Diff Alarm HI	WARN
A014	pH-Diff Alarm HI_HI	FAIL
A015	Temperature-Diff Range	FAIL
A016	Temperature-Diff Alarm LO_LO	FAIL
A017	Temperature-Diff Alarm LO	WARN
A018	Temperature-Diff Alarm HI	WARN
A019	Temperature-Diff Alarm HI_HI	FAIL
A020	ORP-Diff Range	FAIL
A021	ORP-Diff Alarm LO_LO	FAIL
A022	ORP-Diff Alarm LO	WARN
A023	ORP-Diff Alarm HI	WARN
A024	ORP-Diff Alarm HI_HI	FAIL

# Specifications

---

## Specifications M 700 pH 2700

---

### pH/ORP input

(EEx ia IIC)

Measurement range (MR)

Adm. voltage ORP + pH [mV]

Adm. cable capacitance

Glass electrode input

Reference electrode input \*\*

Measurement error \*\*\*

(Display)

---

### Temperature input

(EEx ia IIC)

Measurement range (MR)

Resolution

Measurement error \*\*\*

---

### Temp compensation media-related

Simultaneous pH and ORP measurement

with glass electrode or ISFET

Input for glass electrode or ISFET

Input for reference electrode

Input for redox (ORP) electrode or auxiliary electrode

pH value -2.00 ... +16.00

ORP value -2000 ... +2000 mV

rH value 0.0 ... 42.5

2000 mV

< 2 nF

Input resistance  $> 1 \times 10^{12} \Omega$

Input current  $< 1 \times 10^{-12} \text{ A}$  \*\*\*\*

Impedance range 0.5 ... 1000 M $\Omega$

Input resistance  $> 1 \times 10^{10} \Omega$

Input current  $< 1 \times 10^{-10} \text{ A}$  \*\*\*\*

Impedance range 0.5 ... 200 k $\Omega$

pH value  $< 0.02$  TC  $< 0.001 \text{ pH/K}$

ORP value  $< 1 \text{ mV}$  TC  $< 0.05 \text{ mV/K}$

---

Pt 100/Pt 1000/NTC 30 k $\Omega$ /NTC 8.55 k $\Omega$

3-wire connection, adjustable

-20 ... +150 °C (Pt 100/Pt 1000/NTC 30 k $\Omega$ )

-10 ... +130 °C (NTC 8.55 k $\Omega$ , Mitsubishi)

0.1 °C

0.2 % meas.val. + 0.5 K ( $< 1 \text{ K}$  with NTC  $> 100 \text{ °C}$ )

---

Reference temp 25 °C

# Specifications

---

- Linear temperature coefficient, user-defined from -19.99 to 19.99 % / K
- Ultrapure water 0 ... 150 °C
- Table 0 ... 95 °C, user-defined in 5 K steps

---

## Power output

(EEx ia IIC)

---

for operating an ISFET adapter

+3 V ( $V_o = +2.9 \dots +3.1 \text{ V} / R_i = 360 \Omega$ )

-3 V ( $V_o = -3.5 \dots -3.0 \text{ V} / R_i = 360 \Omega$ )

---

## ORP

ORP sensor standardization \*

---

Automatic conversion to standard hydrogen electrode SHE when type of reference electrode is entered

Zero adjustable from -200 to +200 mV

---

## pH sensor standardization \*

Drift check \*

Calimatic buffer sets: \*

---

1-/2-/3-point calibration (best fit line)

Operating modes:

- Calimatic automatic buffer recognition
- Input of individual buffer values
- Product calibration
- Data entry of pre-measured electrodes

Fine / standard / coarse

- Fixed buffer sets:

1 Mettler-Toledo 2.00 / 4.01 / 7.00 / 9.21

2 Merck/Riedel 2.00 / 4.00 / 7.00 / 9.00 / 12.00

3 DIN 19267 1.09 / 4.65 / 6.79 / 9.23 / 12.75

4 NIST Standard 4.006 / 6.865 / 9.180

5 Techn. buffers to NIST 1.68 / 4.00 / 7.00 / 10.01 / 12.46

6 Hamilton buffer A 2.00 / 4.01 / 7.00 / 9.00 / 11.00

7 Hamilton buffer B 2.00 / 4.01 / 6.00 / 9.00 / 11.00

8 Kraft 2.00 / 4.00 / 7.00 / 9.00 / 11.00

- Manually enterable buffer set with max. three buffer tables (additional function SW700-002)



# Specifications

---

Nom. zero \*

Nom. slope (25 °C) \*

Viso \*

pH 0 ... 14; calibration range  $\Delta\text{pH} = \pm 1$

25 ... 61 mV/pH; calibration range 80 ... 103 %

-1000 ... +1000 mV

---

## Calibration record

Recording of: zero point, slope, Viso, response time, calibration method with date and time

---

## Statistics

Recording of:  
Zero, slope, Viso, response time, glass and reference impedance with date and time of the last three calibrations and the First Calibration

---

## Sensocheck

Automatic monitoring of glass and reference electrode, message can be switched off

---

## Sensoface

Provides information on the sensor condition:  
Zero/slope, response time, calibration interval, Sensocheck, CalCheck (can be disabled)

---

## CalCheck

(Pat DE 195 36 315 C2)

Monitoring of electrode calibration range during measurement

---

## Sensor network diagram

Graphical representation of current sensor parameters in a network diagram on the display: Slope, zero, reference impedance, glass impedance, response time, cal timer, deviation from calibration range (CalCheck)

---

## Sensor monitor

Direct display of measured values from sensor for validation  
pH input / ORP input / glass el. impedance /  
ref. el. impedance / RTD / temperature

---

## KI recorder

(add. function SW700-001)

Adaptive representation of process flow with monitoring and signaling of critical process parameters

# Specifications

---

---

**Adaptive cal timer**\*

(add. function SW700-003)

---

Automatic adjustment of calibration interval  
(Sensoface signal), depending on measured values

---

**ServiceScope**\*

(add. function SW700-004)

---

Monitoring the inputs for overdrive  
Representation on display

---

**Tolerance adjustment**

(add. function SW700-005)

---

Tolerant calibration/adjustment, tolerance limits adjustable,  
graphical recording of zero point and slope of the last  
40 calibrations

- \* User-defined
- \*\* To IEC 746 Part 1, at nominal operating conditions
- \*\*\*  $\pm 1$  count, plus sensor error
- \*\*\*\* at 20 °C, doubles every 10 K

# Specifications

---

## General Data

---

### Explosion protection

(IS module only)

---

ATEX: See rating plate: KEMA 03 ATEX 2056  
II 2 (1) GD EEx ib [ia] IIC T4 T 70 °C

FM: NI, Class I, Div 2, GP A, B, C, D T4  
with IS circuits extending into Division 1  
Class I, Zone 2, AEx nA, Group IIC, T4  
Class I, Zone 1, AEx me ib [ia] IIC, T4

CSA: NI, Class I, Div 2, Group A, B, C, D  
with IS circuits extending into Division 1  
AIS, Class I, Zone 1, Ex ib [ia] IIC, T4  
NI, Class I, Zone 2, Ex nA [ia] IIC

---

### EMC

Emitted interference  
Immunity to interference

---

NAMUR NE 21 and  
EN 61326 VDE 0843 Part 20 /01.98  
EN 61326/A1 VDE 0843 Part 20/A1 /05.99  
Class B  
Industry

---

### Lightning protection

---

EN 61000-4-5, Installation Class 2

---

### Nominal operating conditions

---

Ambient temperature:  
-20 ... +55 °C (Ex: max. +50 °C)  
Rel. humidity: 10 ... 95 % not condensing

---

### Transport/Storage temperature

---

-20 ... +70 °C

---

### Screw clamp connector

---

Single wires and flexible leads up to 2.5 mm<sup>2</sup>

# Appendix:

---

## Minimum Spans for Current Outputs

The pH 2700(X) module is a measuring module. It does not provide current outputs. Current outputs are provided by the BASE module (basic device) or by communication modules (e.g. Out, PID).

The corresponding parameters must be set there.

The minimum current span shall prevent that the resolution limit of the measurement technology ( $\pm 1$  count) is seen in the current.

### **pH 2700(X) Module**

pH	1.00
ORP	100.0
°C	10.0
mV	100.0
rH	1.00
°F	10.0

### **Calculation Block pH/pH**

Diff pH	1.00
Diff ORP	100.0
Diff °C	10.0

# Appendix:

---

## Buffer Table Mettler-Toledo

°C	pH			
0	2,03	4,01	7,12	9,52
5	2,02	4,01	7,09	9,45
10	2,01	4,00	7,06	9,38
15	2,00	4,00	7,04	9,32
20	2,00	4,00	7,02	9,26
<b>25</b>	<b>2,00</b>	<b>4,01</b>	<b>7,00</b>	<b>9,21</b>
30	1,99	4,01	6,99	9,16
35	1,99	4,02	6,98	9,11
40	1,98	4,03	6,97	9,06
45	1,98	4,04	6,97	9,03
50	1,98	4,06	6,97	8,99
55	1,98	4,08	6,98	8,96
60	1,98	4,10	6,98	8,93
65	1,99	4,13	6,99	8,90
70	1,99	4,16	7,00	8,88
75	2,00	4,19	7,02	8,85
80	2,00	4,22	7,04	8,83
85	2,00	4,26	7,06	8,81
90	2,00	4,30	7,09	8,79
95	2,00	4,35	7,12	8,77

# Appendix:

---

Buffer Table Merck / Riedel

°C	pH				
0	2,01	4,05	7,13	9,24	12,58
5	2,01	4,04	7,07	9,16	12,41
10	2,01	4,02	7,05	9,11	12,26
15	2,00	4,01	7,02	9,05	12,10
<b>20</b>	<b>2,00</b>	<b>4,00</b>	<b>7,00</b>	<b>9,00</b>	<b>12,00</b>
25	2,00	4,01	6,98	8,95	11,88
30	2,00	4,01	6,98	8,91	11,72
35	2,00	4,01	6,96	8,88	11,67
40	2,00	4,01	6,95	8,85	11,54
45	2,00	4,01	6,95	8,82	11,44
50	2,00	4,00	6,95	8,79	11,33
55	2,00	4,00	6,95	8,76	11,19
60	2,00	4,00	6,96	8,73	11,04
65	2,00	4,00	6,96	8,72	10,97
70	2,01	4,00	6,96	8,70	10,90
75	2,01	4,00	6,96	8,68	10,80
80	2,01	4,00	6,97	8,66	10,70
85	2,01	4,00	6,98	8,65	10,59
90	2,01	4,00	7,00	8,64	10,48
95	2,01	4,00,	7,02	8,64	10,37

# Appendix:

---

Buffer Table DIN 19267

°C	pH				
0	1,08	4,67	6,89	9,48	13,95*
5	1,08	4,67	6,87	9,43	13,63*
10	1,09	4,66	6,84	9,37	13,37
15	1,09	4,66	6,82	9,32	13,16
20	1,09	4,65	6,80	3,27	12,96
<b>25</b>	<b>1,09</b>	<b>4,65</b>	<b>6,79</b>	<b>9,23</b>	<b>12,75</b>
30	1,10	4,65	6,78	9,18	12,61
35	1,10	4,65	6,77	9,13	12,45
40	1,10	4,66	6,76	9,09	12,29
45	1,10	4,67	6,76	9,04	12,09
50	1,11	4,68	6,76	9,00	11,98
55	1,11	4,69	6,76	8,96	11,79
60	1,11	4,70	6,76	8,92	11,69
65	1,11	4,71	6,76	8,90	11,56
70	1,11	4,72	6,76	8,88	11,43
75	1,11	4,73	6,77	8,86	11,31
80	1,12	4,75	6,78	8,85	11,19
85	1,12	4,77	6,79	8,83	11,09
90	1,13	4,79	6,80	8,82	10,99
95	1,13*	4,82*	6,81*	8,81*	10,89*

\* extrapoliert / extrapolated / extrapolée

# Appendix:

---

Buffer Table NIST Standard (DIN 19266: 2000-01)

°C	pH			
0				
5	1.668	4.004	6.950	9.392
10	1.670	4.001	6.922	9.331
15	1.672	4.001	6.900	9.277
20	1.676	4.003	6.880	9.228
<b>25</b>	<b>1.680</b>	<b>4.008</b>	<b>6.865</b>	<b>9.184</b>
30	1.685	4.015	6.853	9.144
37	1.694	4.028	6.841	9.095
40	1.697	4.036	6.837	9.076
45	1.704	4.049	6.834	9.046
50	1.712	4.064	6.833	9.018
55	1.715	4.075	6.834	9.985
60	1.723	4.091	6.836	8.962
70	1.743	4.126	6.845	8.921
80	1.766	4.164	6.859	8.885
90	1.792	4.205	6.877	8.850
95	1.806	4.227	6.886	8.833

---

## Notice:

The pH(S) values of the individual charges of the secondary reference materials are documented in a certificate of an accredited laboratory. This certificate is supplied with the respective buffer materials. Only these pH(S) values shall be used as standard values for the secondary reference buffer materials. Correspondingly, this standard does not include a table with standard pH values for practical use. The table above only provides examples of pH(PS) values for orientation.



# Appendix:

---

## Buffer Table Techn. Buffers to NIST

°C	pH		
0	4.00	7.14	10.30
5	4.00	7.10	10.23
10	4.00	7.04	10.11
15	4.00	7.04	10.11
20	4.00	7.02	10.05
25	4.01	7.00	10.00
30	4.01	6.99	9.96
35	4.02	6.98	9.92
40	4.03	6.98	9.88
45	4.05	6.98	9.85
50	4.06	6.98	9.82
55	4.07	6.98	9.79
60	4.09	6.99	9.76
65	4.09 *	6.99 *	9.76 *
70	4.09 *	6.99 *	9.76 *
75	4.09 *	6.99 *	9.76 *
80	4.09 *	6.99 *	9.76 *
85	4.09 *	6.99 *	9.76 *
90	4.09 *	6.99 *	9.76 *
95	4.09 *	6.99 *	9.76 *

---

\* Values complemented

# Appendix:

---

## Buffer Table Hamilton A

°C	pH				
0	1.99	4.01	7.12	9.31	11.42
5	1.99	4.01	7.09	9.24	11.33
10	2.00	4.00	7.06	9.17	11.25
15	2.00	4.00	7.04	9.11	11.16
20	2.00	4.00	7.02	9.05	11.07
<b>25</b>	<b>2.00</b>	<b>4.01</b>	<b>7.00</b>	<b>9.00</b>	<b>11.00</b>
30	1.99	4.01	6.99	8.95	10.93
35	1.98	4.02	6.98	8.90	10.86
40	1.98	4.03	6.97	8.85	10.80
45	1.97	4.04	6.97	8.82	10.73
50	1.97	4.05	6.97	8.78	10.67
55	1.98	4.06	6.98	8.75	10.61
60	1.98	4.08	6.98	8.72	10.55
65	1.98	4.10	6.99	8.70	10.49
70	1.99	4.12	7.00	8.67	10.43
75	1.99	4.14	7.02	8.64	10.38
80	2.00	4.16	7.04	8.62	10.33
85	2.00	4.18	7.06	8.60	10.28
90	2.00	4.21	7.09	8.58	10.23
95	2.00	4.24	7.12	8.56	10.18

# Appendix:

---

## Buffer Table Hamilton B

°C	pH				
0	1.99	4.01	6.03	9.31	11.42
5	1.99	4.01	6.02	9.24	11.33
10	2.00	4.00	6.01	9.17	11.25
15	2.00	4.00	6.00	9.11	11.16
20	2.00	4.00	6.00	9.05	11.07
<b>25</b>	<b>2.00</b>	<b>4.01</b>	<b>6.00</b>	<b>9.00</b>	<b>11.00</b>
30	1.99	4.01	6.00	8.95	10.93
35	1.98	4.02	6.00	8.90	10.86
40	1.98	4.03	6.01	8.85	10.80
45	1.97	4.04	6.02	8.82	10.73
50	1.97	4.05	6.04	8.78	10.67
55	1.98	4.06	6.06	8.75	10.61
60	1.98	4.08	6.09	8.72	10.55
65	1.98	4.10	6.11	8.70	10.49
70	1.99	4.12	6.13	8.67	10.43
75	1.99	4.14	6.15	8.64	10.38
80	2.00	4.16	6.18	8.62	10.33
85	2.00	4.18	6.21	8.60	10.28
90	2.00	4.21	6.24	8.58	10.23
95	2.00	4.24	6.27	8.56	10.18

# Appendix:

---

## Buffer Table Kraft

°C	pH				
0	2.01	4.05	7.13	9.24	11.47*
5	2.01	4.04	7.07	9.16	11.47
10	2.01	4.02	7.05	9.11	11.31
15	2.00	4.01	7.02	9.05	11.15
<b>20</b>	<b>2.00</b>	<b>4.00</b>	<b>7.00</b>	<b>9.00</b>	<b>11.00</b>
25	2.00	4.01	6.98	8.95	10.85
30	2.00	4.01	6.98	8.91	10.71
35	2.00	4.01	6.96	8.88	10.57
40	2.00	4.01	6.95	8.85	10.44
45	2.00	4.01	6.95	8.82	10.31
50	2.00	4.00	6.95	8.79	10.18
55	2.00	4.00	6.95	8.76	10.18*
60	2.00	4.00	6.96	8.73	10.18*
65	2.00	4.00	6.96	8.72	10.18*
70	2.01	4.00	6.96	8.70	10.18*
75	2.01	4.00	6.96	8.68	10.18*
80	2.01	4.00	6.97	8.66	10.18*
85	2.01	4.00	6.98	8.65	10.18*
90	2.01	4.00	7.00	8.64	10.18*
95	2.01	4.00	7.02	8.64	10.18*

\* Values complemented

# Buffer Sets to be Entered: SW 700-002

Select menu: Parameter setting/System control/Buffer table  
 Individual buffer set (with 3 buffer solutions) for pH measurement

## Buffer Table

You can enter an individual buffer set. To do so, you enter 3 complete buffer solutions in ascending order (e.g. pH 4, 7, 10) for the correct temperature (range 0 ... 95 °C, 5 °C steps).

Distance between buffers in the whole temperature range: min. 1 pH unit.  
 Then this buffer set is available in addition to the permanently set standard buffer solutions in the "Calimatic buffer" menu (select "Table").

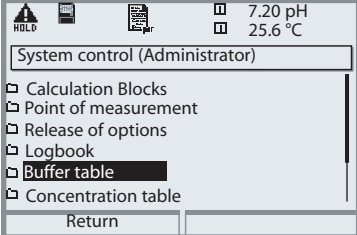
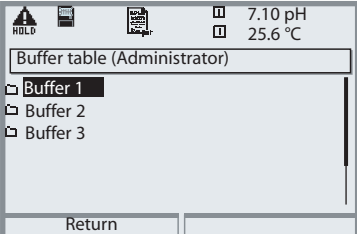
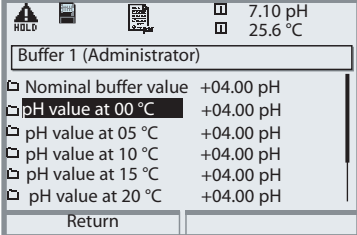
Menu	Display	Buffer table: Entering values
		<p><b>Enter buffer set</b></p> <ul style="list-style-type: none"> <li>• Call up parameter setting</li> <li>• System control</li> <li>• Select "Buffer table"</li> </ul>
		<ul style="list-style-type: none"> <li>• Select buffer to be entered. 3 complete buffer solutions must be entered in ascending order (e.g. pH 4, 7, 10). Minimum distance: 1 pH unit</li> </ul>
		<ul style="list-style-type: none"> <li>• Enter nominal buffer value and all other values for the correct temperature (right/left arrow keys to select position, up/down arrow keys to edit number, confirm with <b>enter</b>.)</li> </ul>

**The special buffer set** is selected as follows:

Parameter setting/Module pH/Cal preset values/Calimatic buffer/Table.

# Overview of Parameter Setting

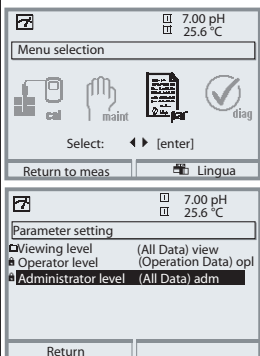

## Parameter setting

Activated from measuring mode: Press **menu** key to select menu.

Select parameter setting using arrow keys, confirm with **enter**.

### Administrator level

Access to all functions, also passcode setting.

Releasing or blocking a function for access from the Operator level.

### Operator level

Access to all functions which have been released at the Administrator level. Blocked functions are displayed in gray and cannot be edited.

### Viewing level

Only display, no editing possible!

## System Control

### Memory card (Option)

- Record logbook
- Register recorder
- Decimal separator
- Card full
- Format

Menu only appears with SmartMedia Card inserted.

Make sure that it is a memory card, not an update card.

Commercially available SmartMedia cards must be formatted before they can be used as memory card.

### Copy configuration

The complete configuration of an analyzer can be written on a SmartMedia card. This allows transferring all device settings to other devices with identical equipment (exception: options and passcodes).

### Parameter sets

- Load
- Save

2 parameter sets (A,B) are available in the analyzer.

The currently active parameter set is read on the display.

Parameter sets contain all settings except:

Sensor type, Options, System control settings

Up to 5 parameter sets (1, 2, 3, 4, 5) are available when a SmartMedia card (Option) is used.

### Function control matrix

- Input OK2
- Left softkey
- Right softkey

Selecting the control element for the following functions:

- Parameter set selection
- KI recorder (Start/Stop)
- Favorites menu (selected diagnostics functions)
- EC 400 (fully automated probe controller)

Time/date

Selecting the display format, entry

Point of meas description

Can be called up in the diagnostics menu.

Release of options

A TAN is required to release an Option.

Software update

Software update from SmartMedia card (update card)

Logbook

Selecting events to be recorded

Buffer table

Entering own buffer set for automatic calibration

Factory setting

Resetting all parameters to factory setting

Passcode entry

Editing the passcodes

# Parameter Setting Menu



## Display Settings: FRONT Module

### Languages

Measurement display <ul style="list-style-type: none"> <li>• Main display</li> <li>• Display format</li> <li>• Viewing angle</li> </ul>	Representation of measured values on the display: <ul style="list-style-type: none"> <li>- Selecting the number of primary values displayed (one or two)</li> <li>- Decimal places</li> </ul>
Measurement recorder <ul style="list-style-type: none"> <li>• Time base</li> <li>• Zoom function</li> <li>• Min/Max display</li> </ul>	Option: 2-channel, selection of process variable, start and end
KI recorder	Option: See more detailed "Options" manual

## Signal Outputs and Inputs, Contacts: BASE Module

Output current I1, I2 <ul style="list-style-type: none"> <li>• Variable</li> <li>• Curve</li> <li>• Output (0/4 - 20 mA)</li> <li>• Output filter</li> <li>• Behavior during messages                     <ul style="list-style-type: none"> <li>- HOLD</li> <li>--- Current meas.</li> <li>--- Last meas. value</li> <li>--- Fixed 22 mA</li> <li>- 22 mA message</li> </ul> </li> </ul>	2 current outputs, separately adjustable  Behavior during messages Output current [mA]
Contact K4 <ul style="list-style-type: none"> <li>• Contact type</li> <li>• ON delay</li> <li>• OFF delay</li> </ul>	NAMUR Failure
Contacts K3, K2, K1 <ul style="list-style-type: none"> <li>• Usage                     <ul style="list-style-type: none"> <li>- Maintenance request</li> <li>- HOLD (function check)</li> <li>- Limit value (adjustable)</li> <li>- Rinse contact (adjustable)</li> <li>- Parameter set B active</li> <li>- USP output</li> <li>- KI recorder active</li> <li>- Sensoface</li> </ul> </li> <li>• Conoller alarm (alarm output EC 400)</li> <li>• Contact type / ON/OFF delay</li> </ul>	Factory setting: K3: Maintenance request, K2: HOLD, K1: Limit  <ul style="list-style-type: none"> <li>- Variable, limit value, hysteresis, effective direction, ...</li> <li>- Rinsing interval, lead times, rinse duration, logbook entry, ...</li> </ul>
Inputs OK1, OK2 <ul style="list-style-type: none"> <li>• OK1 usage                     <ul style="list-style-type: none"> <li>- Signal level</li> </ul> </li> </ul>	Optocoupler - signal inputs Off, HOLD (function check) active level switchable from 10 to 30 V or < 2 V, resp. For OK2 see System control/Function control matrix

# Parameter Setting Menu



## pH 2700(X) Module

### Input filter

#### Sensor data

- Sensor type
- Temperature detection
- Sensoface
- Sensor monitoring

#### Details

- Slope
- Zero point
- Sensocheck ref. el.
- Sensocheck glass el.
- Response time
- Calcheck

#### Representation of measured values on the display:

- Select
- Selection for Measurement / Calibration

### Cal preset values

- Calimatic buffer
- Mettler-Toledo
- Merck/Riedel
- DIN 19267
- NIST standard
- NIST technical
- Hamilton A
- Hamilton B
- Kraft
- Table
- Drift check
- Calibration timer
- Tolerance adjustment
- ORP check

### TC process medium

Select: Off, linear, ultrapure water, table

### ORP/rH value

- Reference electrode
- ORP conversion to SHE
- Calculate rH with factor

### Delta function

#### Messages

- pH value
- ORP value
- rH value
- Temperature
- mV value



# Calibration Menu



## pH 2700(X) Module

Calimatic  
Entry of buffer values  
Product calibration  
Data entry  
ORP calibration

# Maintenance Menu



## BASE Module

Current source                      Output current definable 0 ... 22 mA

## pH 2700(X) Module

Sensor monitor                      pH / ORP input, RTD, Temp, Impedance glass + ref. el.  
Temp probe adjustment              Compensating for lead length

# Diagnostics Menu



Message list                      List of all warning and failure messages  
Point of meas description  
Logbook  
Device description                      Hardware version, Serial no., (Module) Firmware, Options

## FRONT Module

Module diagnostics  
Display test  
Keypad test

## BASE Module

Module diagnostics  
Input/output status

## pH 2700(X) Module

Module diagnostics                      Internal function test  
Servicescope                      pH input signal: Displays the noise levels over the time  
Sensor monitor                      Shows the values currently measured by the sensor  
Cal record                      Data of last adjustment / calibration  
Cal record ORP                      Data of last ORP adjustment / calibration  
Sensor network diagram pH              Graphical representation of the sensor parameters  
Statistics                      Displays first calibration and deviations of last 3 calibrations

# Index

---

M700 pH 2700(X)

## A

Adaptive calibration timer 87  
Adjustment 31  
Administrator level 48  
Appendix 100  
Application in hazardous locations 11  
Automatic buffer recognition (Calimatic) 36  
Automatic temperature compensation 33

## B

BASE module 17  
Behavior during messages 75  
Buffer sets to be entered 109  
Buffer tables 101  
Buffer values, manual entry for calibration 38

## C

Cable glands 14  
Calculation Blocks 65  
Calibration 30  
Calibration by entering data from premeasured electrodes 42  
Calibration methods 32  
Calibration timer 87  
Calibration with sampling 40  
Calimatic 36  
Call up parameter setting 50  
Cal preset values 57  
Cal record 88  
Change passcode 27  
Configure measurement display 28  
Contacts 71  
Contact type 80  
Current output curves 72

# Index

---

M700 pH 2700(X)

Current outputs 71, 75

Current outputs, minimum spans 100

## D

Data entry of premeasured electrodes 42

Delta function 64

Device limits max. 70

Device software 12

Diagnostics messages 91

Diagnostics messages as favorite 89

Disposal 2

Documenting the settings 51

## E

EC Declaration of CO conformity 3

EMC 99

Error messages 92

## F

Factory setting 68

Failure 76

Favorites 89

FDA 21 CFR Part 11 10

First Calibration 32

FRONT module 16

Function check 76

## G

Graphic display 14

## H

Hardware and software version 12

HOLD 76

Hysteresis 80

# Index

---

M700 pH 2700(X)

## I

Inserting the module 20

Intended use 10

ISFET zero adjustment 46

## L

LED 14

Limit value 80

Limit value, icons in the measurement display 80

Linear characteristic 72

Lock functions 49

Lock icon 49

Logarithmic output curve 73

Logbook 68, 86

## M

Maintenance 83

Manual entry of buffer values 38

Manual temperature compensation 33

Menu selection 26

Menu structure 15, 26

Message icons 70

Message list 86, 91

Messages 70, 92

Messages, behavior of current outputs 75

Message when the current range is exceeded 75

Minimum spans for current outputs 100

Modular concept 13

Module diagnostics 86

Module equipment 17

Modules 16

Module software 12

Monitoring functions for calibration 43

# Index

---

M700 pH 2700(X)

## O

OK1/OK2 inputs 81  
OK1/OK2 switching level 81  
OK1 usage 81  
OK2, selecting parameter set (A, B) 82  
OK inputs 71  
One-point calibration 32  
Operating levels 48  
Operator level 48  
ORP/rH value 64  
ORP calibration/adjustment 44  
ORP related to the standard hydrogen electrode 44  
Output filter 74  
Overview of parameter setting 110

## P

Parameter setting 51  
Parameter setting, overview 110  
Parameter setting: cal preset values 57  
Parameter setting: ORP/rH value 64  
Parameter setting: Sensor data 53  
Parameter setting documentation 51  
Passcode entry 27  
Passcode lost 27  
Product calibration 40  
Protective wiring 77

## Q

Query actual device/module software 12

## R

Relay contacts 76  
Relay contacts, usage 78, 79  
Release (softkey function) 49  
Replacing the front module 16

# Index

---

M700 pH 2700(X)

Return of products 2

Rinse contact 79

## S

Safety information 11

Screw clamp connector 99

Sealing 16

Secondary displays 14, 28

Select a calibration method 34

Sensoface 55

Sensoface criteria 56

Sensor data 53

Sensor monitor 83

Sensor monitoring details 54

Sensor network diagram 88

Serial number 12

Shield 20

Short description 14

Signaling active parameter set via relay contact 82

Slot for SmartMedia card 16

SmartMedia card 16

Softkeys 14, 28

Softwareversion 12

Specifications 95, 99

Start (4 mA) and end (20 mA) 71

Statistics 88

Switching parameter sets via OK2 82

## T

Table of contents 6

TC process medium 61

Temperature compensation during calibration 33

Temperature compensation of process medium 63

Temperature dependence of commonly used reference systems measured against SHE 45

# Index

---

M700 pH 2700(X)

Temperature probe adjustment 83  
Temp probe adjustment 83  
Terminal compartment 17  
Terminal plates 16, 19  
Three-point calibration 32  
Tolerance adjustment 57, 87  
Trademarks 2  
Two-point calibration 32

## **V**

Variable limits 70  
Viewing level 48

## **W**



















Warranty 2  
Wiring examples 21





---



Icon	Explanation of icons important for this module
	The analyzer is in measuring mode.
 	The analyzer is in calibration mode. HOLD mode active for currently calibrated module.
 	The analyzer is in maintenance mode. HOLD mode active.
 	The analyzer is in parameter setting mode. HOLD mode active.
	The analyzer is in diagnostics mode.
<b>NAMUR signals</b> 	Function check. The NAMUR "function check" contact is active (factory setting: Module BASE, Contact K2, N/O contact). Current outputs as configured: <ul style="list-style-type: none"> <li>• Current meas.: The currently measured value appears at the current output</li> <li>• Last usable value: The last measured value is held at the current output</li> <li>• Fixed 22 mA: The output current is at 22 mA</li> </ul>
	Failure. The NAMUR "failure" contact is active (factory setting: Module BASE, Contact K4, N/C contact). To view error message, call up: Diagnostics menu/Message list
	Maintenance. The NAMUR "maintenance request" contact is active (factory setting: Module BASE, Contact K2, N/O contact). To view error message, call up: Diagnostics menu/Message list
	Limit indication: Lower / upper range limit exceeded
	Temperature detection by manual input
	Calibration - Step 1 of product calibration has been executed. The analyzer is waiting for the sample values.
TC	Calibration: Temperature compensation for process medium is active (Linear/Ultrapur water/Table)
Δ	Delta function is active (Output value = measured value – delta value)
	In the plaintext display in front of a menu line: Access to next menu level with enter
	In the plaintext display in front of a menu line when it has been blocked by the Administrator against access from the Operator level.
	Designates the module slot (1, 2 or 3), allowing the clear assignment of measured-value/parameter displays in the case of identical module types.
	Indicates the active parameter set. (The analyzer provides two parameter sets A and B. Up to 5 sets can be added using additional functions and SmartMedia card.)

# Menu Selection pH 2700(X) Module

---



<b>Calibration and adjustment.....</b>	<b>30</b>
Calimatic: automatic calibration.....	36
Calibration with manual entry of buffer values .....	38
Product calibration.....	40
Data entry of premeasured electrodes.....	42
ORP calibration .....	44
ISFET zero adjustment.....	46

---



<b>Parameter setting .....</b>	<b>48</b>
Documenting.....	51
Sensor data .....	53
Sensoface .....	54
Cal preset values.....	57
TC process medium .....	62
ORP/rH value .....	64
Logbook .....	68
Factory setting .....	68
Messages.....	69

---



<b>Maintenance.....</b>	<b>83</b>
Sensor monitor .....	83
Temperature probe .....	83

---



<b>Diagnostics .....</b>	<b>84</b>
Module diagnostics, Sensor monitor .....	85
ServiceScope.....	85
Message list.....	86
Calibration timer.....	87
Tolerance adjustment.....	87
Cal record, Sensor network diagram, Statistics.....	88
Setting diagnostics messages as favorite .....	89
Message list.....	91
Logbook .....	68, 91