

Interface Converter ACM200-AC / ACM200-DC



The interface converter ACM200 is used as a barrier between the hazardous and the safe area. Furthermore, it is a communication module for weight data to a peripheral device or a METTLER TOLEDO weighing terminal. Communication is made via a RS232, RS422/485 or CL20mA interface.

Technical Data

Housing / Ambience	
Material	chrome-nickle steel (AISI 304, 1.4301)
Storage temperature	-20°C ... +60°C
Relative humidity	10...85%, not condensing
weight	gross: 3,4kg (inclusive packaging)

Maximum cable length	
ACM200-AC /-DC – IND226x	300m
ACM200-AC/-DC – peripheral device	10m (RS232) 100 m (RS422/485/CL20mA)

Power supply	
ACM200-AC wide-range power supply	100...240 VAC 50/60Hz
ACM200-DC without wide-range power supply	24 VDC
Approvals, expertises	
Explosion protection approval	ATEX II (2) G [Ex ib Gb] II C II (2) D [Ex ib Db] III C -10°C...+40°C
	IECEx: [Ex ib Gb] II C [Ex ib Db] III C -10°C...+40°C
	FM: AIS Class I, II, III; Division 1; Group A, B, C, D, E, F, G
Housing protection approval	IP66 (EN 60529)
EMC	NAMUR-recommendation, MT-guideline, standards: EN 61000-6-1 EN 61000-6-3 EN 61000-4-3 (10V/m) EN 61000-4-6 (10V)

Dimensions

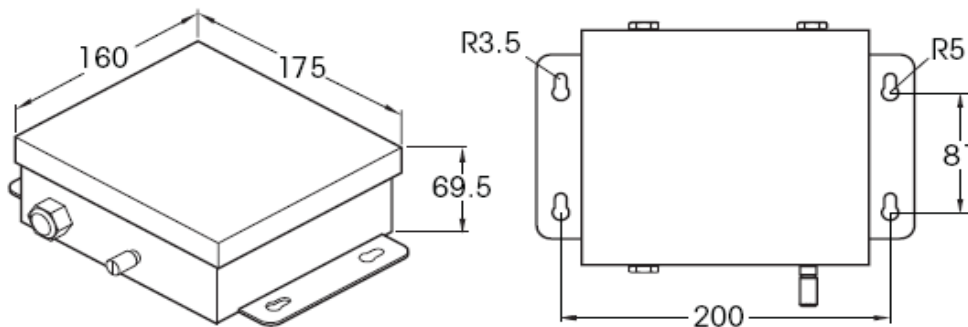

Measurements in mm

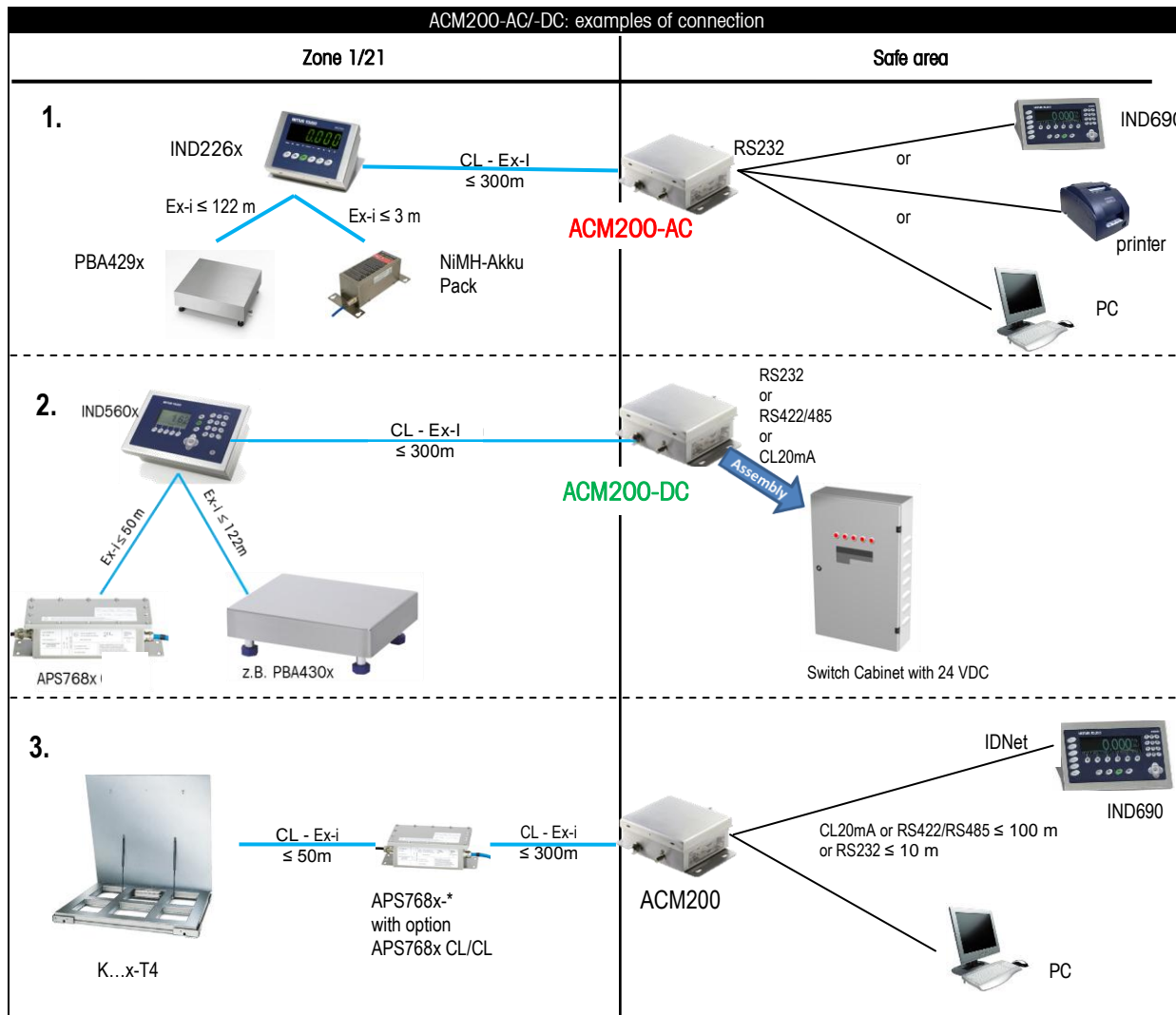

Product	Order number MTA
IND226x weighing terminal	22018011
Interface IND, communication to safe area	22018012
Interface Remote, within hazardous area	22018013

Product	Order Number MTA
ACM200-AC interface converter	22016767
ACM200-DC interface converter	22023347
O-ACM200-RS422/RS485	22023348
O-ACM200-CL20mA	22023349

Essential Services for Dependable Performance

METTLER TOLEDO is uniquely qualified to provide the installation, calibration and maintenance services essential to ensuring accuracy, optimizing uptime and prolonging equipment life. Our service representatives will be there at the right time, with the right parts, the right tools and the right skills to meet your needs.



www.mt.com

For more information

Subject to technical changes!

**Mettler-Toledo (Changzhou)
Measurement Technology Ltd.**
10 Kunlun Road, Changzhou Xinbei District,
Jiangsu Province, P.R. China 213125
Phone 0086-519-664-2040
Fax 0086-519-664-1991.