

TLW450 Dynamic Scale

Up to 11,000 Parcels Per Hour



Efficient Project Planning and Implementation

Systems are designed according to your unique specifications using a configurator that creates a drawing and specification. Quick, easy access to this information facilitates project planning. An HMI with 32 standard languages supports cross-border implementation.



Top Measuring Results in Tough Conditions

Advanced filter technology and rugged system design minimize disturbances that affect accuracy in tough conditions, like on a mezzanine.



Fast, Efficient Sorting and Data Transfer

Approved to measure at 3 m/s, the TLW450 is one of the fastest scales on the market. Fastest real-time controller ensures high-speed data communication with the sorter. Data drop can be configured based on sorting requirements.



Cost-Effective Integration into Any Sorting System

A wide variety of design configurations, interfaces, protocols and features means little restructuring, re-engineering or changes to IT infrastructure are required.



Flexible, Accurate, Robust High-Speed Parcel Scales

Designed to fulfil the most demanding system integration requirements, TLW450 dynamic scales are designed for integration into any material handling system for revenue recovery, revenue protection, receiving and shipping.

State-of-the-art load-cell technology provides top weighing accuracy at high speeds while maintaining high throughputs. The scales can be combined with any dimensioner, camera or barcode reader and come with a wide range of options and configurations.

TLW450

Dynamic Parcel Weighing

Whenever parcels need to be weighed in-motion at high speeds, the TLW450 provides accurate, legal-for-trade results. The scales are fully configurable and can be tailored to meet individual operational or system integration needs.

Features and Benefits

Advanced filter technology stabilizes results in high-speed environments.
Flexible weighing point increases weighing throughput by up to 30%.
Weights and Measures certified in the US and Europe for use in legal-for trade applications.
High-speed data communication with a real-time controller.
Configurable data drop position for sorting efficiency.
High-quality mechanical design for high performance in tough conditions.
Standard interfaces offer the possibility to standardize dimensioning, weighing and scanning solutions.
Customized data communication protocols for flexible integration.
Status messages and error codes give clear overview of system operation and alert to potential problems.
Multi-lingual weighing terminal for operator efficiency and cross border installation and service.
Bright, high-contrast colour touchscreen display, 7" widescreen, 800 x 480 px for clear display of data.

Options and Accessories

Customized interfacing options for data transmission
Control cabinet mounted on frame or as a free-standing unit.
Dimension merging
Barcode merging
Item IDs, counter and time stamp

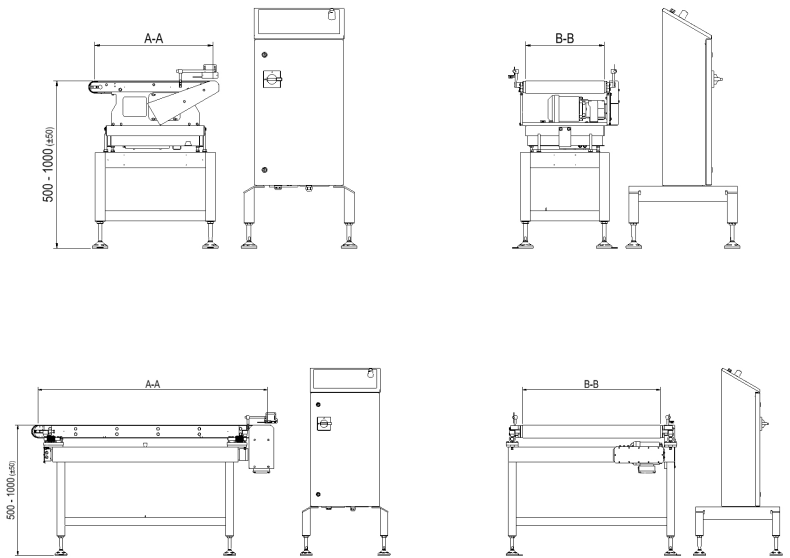

Technical Specifications	TLW450 (EMFR)	TLW450 (DMS)
Weighing range	0 - 100 lb	
Accuracy	± 0.02 lb	± 0.1 lb
Speed	300 fpm	590 fpm
Throughput	Up to 11,000 pcs/h*	
Roller centres, weighing conveyor (A-A)	800, 1000, 1200**, 1500**, 1700**, 2000**, 2500 mm**	800, 1000, 1200, 1500, 1700, 2000, 2500 mm
Belt width, weighing conveyor (B-B)	500, 600, 800**, 900**, 1000**, 1100** mm	500, 600, 800, 900, 1000, 1100 mm
Voltage	120VAC single phase, 50/60 Hz 240VAC single and 3-phase, 50/60 Hz 480VAC 3-phase, 50/60 Hz	
Standard Protocols	Mettler-Multi Range, Weight 8C, Custom	
Interfacing	Ethernet, TCP/IP, Serial, Fieldbus	
NTEP Certification	CoC 10-018	CoC 11-022
Load Cells	EMFR	Strain Gauge

*Throughput will vary depending on parcel length and gapping.

**Not NTEP approved..

METTLER TOLEDO Service with global reach and tailored care solutions.

www.mt.com/TLW450

For more information

METTLER TOLEDO Group

Transport and Logistics
Local contact: www.mt.com/transport

Subject to technical changes
©09/2020 METTLER TOLEDO. All rights reserved
30526924