

MT-55T Auto Filler Auto Multi-Drum and Tote Filler



Accuracy

Fill containers by weight to obtain precise material delivery. Advanced electronics and high repeatability prevent under-filled and over-filled containers keeping you in compliance without giving away product.



Environment

Built in safety features and special construction allows these filling systems to be used in all types of environments. Options include 3A sanitary lances, hazardous area designs, and full stainless steel construction.



Connect

Drop these filling systems into existing conveyor lines, integrate with labelers or other peripherals, and transfer data to your PLC or PC.

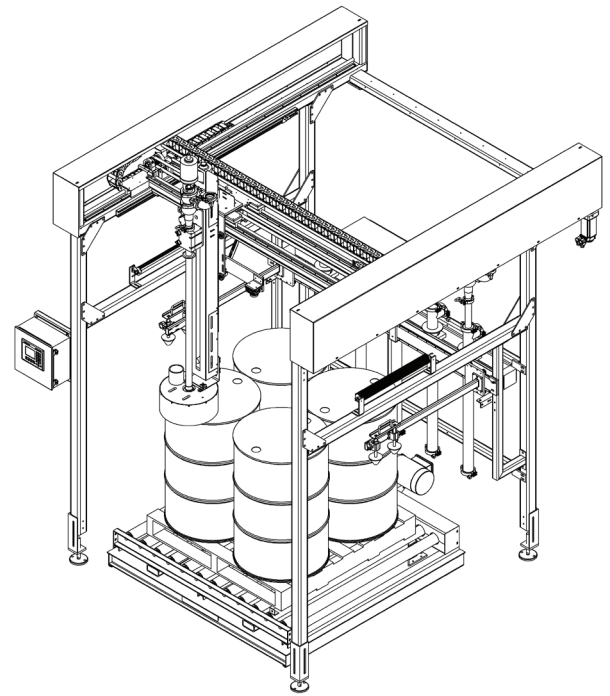

Complete Filling Solutions Accurate, Efficient and Safe

From simple pail to IBC's, these filling systems offer safe and accurate solutions for most liquid filling applications. Standard features include stainless steel construction for all parts contacting product, proximity switches for accurate control and safety, dual ball valves for 2 speed delivery, and a remote operator station. The IND560 weighing controller adds high speed A/D rates, advanced digital filtering, and a broad array of communications capabilities. Application highlights include programmable timers, target memory and recall, and intuitive operator interfaces. Fill containers efficiently and accurately with METTLER TOLEDO filling systems.

Technical data

This machine is designed to automatically fill 4 drums on pallet, with included bung locators, or totes. Unit becomes fully automatic when upgraded with optional vision system.

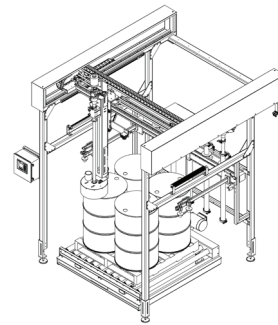

MT-55T Automatic Drum and Tote Filler

<p>Standard Features (Filler)</p>	<ul style="list-style-type: none"> ▪ Stainless Steel Product Lance ▪ Steel Framing ▪ 2" NPT material delivery system, 316 stainless steel ▪ Foot valve with safety failed closed design ▪ Proximity switches for accurate positioning and safety interlocking ▪ Servo-controlled X&Y Lance Positioning 	<ul style="list-style-type: none"> ▪ Dual ball valves for 2-speed product delivery and accurate fill control ▪ Self-draining Drip Cup ▪ Remote operator station ▪ Pneumatic air motor (lance) ▪ Surface and subsurface filling for non-foaming or foaming materials ▪ Manual Height Adjustment for multiple sizes
<p>Standard Features (Controller)</p>	<ul style="list-style-type: none"> ▪ 200 product fill data storage ▪ Ethernet connection ▪ ± filling tolerance ▪ No feed timer ▪ Multiple product menus ▪ Prefill target ▪ Decrementing container counter ▪ Allen Bradley PanelView 400+ 	<ul style="list-style-type: none"> ▪ IND560 terminal ▪ No container / no fill ▪ Lance flush by time or weight ▪ Product flow rate check ▪ AB CompactLogix™ PLC ▪ Cycle timer ▪ Final cutoff delay ▪ Resume fill
<p>Environmental Protection</p>	<ul style="list-style-type: none"> ▪ Non-wetted parts: Painted CRS Framing with Stainless Steel Sheet Metal Components ▪ Wetted parts: 316 stainless steel piping systems with PTFE seals ▪ Standard TYPE NEMA 12 Controller enclosure. Other enclosures optional ▪ OPTIONAL Hazardous Area X-Purge, Suitable for Class I & II: Division 1 & 2; Group C, D, E, F, G; T4 * ▪ OPTIONAL Hazardous Area Z-purge Suitable for Class I & II: Division 2; Group C, D, E, F, G; T4 * 	
<p>Optional Features</p>	<ul style="list-style-type: none"> ▪ Conveyor Packages ▪ Fume Hood ▪ Powered drip cup ▪ Stainless Steel construction ▪ 3A Sanitary Lance 	<ul style="list-style-type: none"> ▪ NEMA 4 Enclosures ▪ Fume evacuation system ▪ Additional lances and flush system ▪ Nitrogen Purge ▪ Cognex Vision System
<p>Accessories</p>	<ul style="list-style-type: none"> ▪ 60" x 60" Floor scale ▪ Scale conveyor ▪ Controller modifications for conveyor sequencing or special logic ▪ Ground fault detector software and hardware modifications to verify ground before starting to fill (includes ground clamp) ▪ Controller convenience kit (complete list is available upon request) ▪ Complete Line Integration ▪ Data Collection Programming 	

*Optional Agency Approval on System – Contact a sales representative to learn more.

www.mt.com/industrial

For more information

METTLER TOLEDO

 USA
 1900 Polaris Parkway
 Columbus, Ohio 43240
 Tel. (800) 786-0038
 Fax (614) 438-4518

 Canada
 2915 Argentia Road, Unit 6
 Mississauga, Ontario L5N 8G6
 Tel. (800) 523-5123

Specifications subject to change without notice METTLER TOLEDO® is a registered trademark of Mettler-Toledo, LLC.
 IND-2313-LIT