

Count on performance

Combined weighing and price labeling for your products

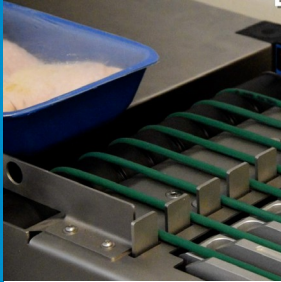

Increase efficiency

With its stop system located at the front of the machine, the FreshPack solution allows you to set the product processing speed for any modified atmosphere packaging system.

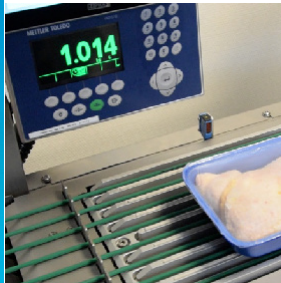

Increase accuracy

With its Mettler Toledo Retail Stop and Start weighing system, the FreshPack solution ensures that you can weigh all your products reliably and accurately up to 6 kg.



Increase productivity

Operating at a speed of 25 packages per minute and offering an automatic sticker applicator option, the FreshPack solution helps you save time and significantly increase productivity in your backroom.



Increase simplicity

Through its simplified and robust design, the FreshPack solution offers a first-rate cleaning and maintenance process that's easy to use for all operators.

Maintenance simplifiée



The FreshPack solution is available in 1 or 2 printer versions

METTLER TOLEDO Retail's FreshPack improves backroom performance. The additional POP label printer can print logos on blank, multi-color sticker rolls, so you can customize your logos and create optimum communication with your customer. The automatic sticker applicator helps you save time and increases your productivity. You can do everything from a simple, user-friendly interface. You can be confident that your shelves will be perfectly presented, generating additional sales.

METTLER TOLEDO

The ideal choice for optimizing your backrooms

Reliable, intuitive, and fast, to provide you with high-quality packaging, METTLER TOLEDO Retail's FreshPack weigh price labeling solution is the ideal tool for high-production backroom environments.

- Versatility: POP label printer can easily be added to the frame.
- Easy to change tray conveyor belts
- Intuitive user interface: touch panel and tactile keypad
- Hygienic design. Easy to clean
- Blow-on label applicator
- Footprint: 0.9 m²



Technical features FreshPack Weigh Price Labeling

Speed

Up to 25 trays per minute

Trays *1 in mm

Min width: 95; max: 380

Min depth: 80; max: 260

Min height: 10; max: 100 (package),
90 (tray)

TOP sticker

Min width: 35 to 80 mm

Min length: 30 to 100 mm

Inside diameter: 76 mm

Maximum outside diameter:

From 200 to 305 mm

Footprint

Approximately 0.9 m²

Compressed air

Air pressure 4.5 to 6 bars

Consumable:

FreshPack 1 printer 8 m³/h

FreshPack 2 printer 15 m³/h

Weight

Model 1 printer 180 kg

Model 2 printer 250 kg

Operating temperature

5 °C – 35 °C

POP sticker

Min width: 50 mm

Min length: 50 mm

Inside diameter: 76 mm

Maximum outside diameter:
from 200 to 305 mm

Logo file format

Monochrome BMP format

Power supply

230 volts, single phase,
50 Hz, 2 kVA,

Operating system

Embedded Windows 10

SATA hard disk memory

Screen/keyboard

Color touch panel
2256 x 1504 pixels, 13.5"
IP65

Direct PLU

Configurable

Capacity, increments

Capacity: 6 kg

Increments: 2 g

Mechanical features FreshPack Weigh Price Labeling

FRESHPACK (1 labeling station)

Length	1130 mm
Width	565 mm
Height	1340 mm
Weight	180 kg

FRESHPACK (2 labeling stations)

Length	1530 mm
Width	565 mm
Height	1340 mm
Weight	250 kg

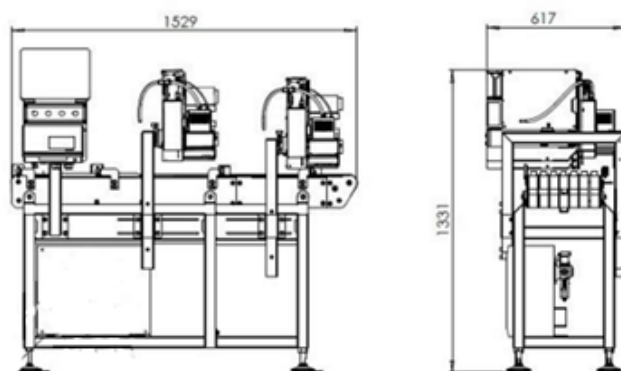

*1 Maximum not compatible

*2 Minimum not compatible



Mettler-Toledo SAS
18, 20 avenue de la Pépinière
78222 Viroflay cedex
Tel: 01 30 97 17 17
email: marcom.fr@mt.com

Subject to modifications to technical
features and functions
07/2022 Mettler-Toledo SAS

www.mt.com/retail

For more information