

Boost Productivity

Optimized Wrapping System



Increased Productivity

The intuitive user interface of the FreshBase Controller simplifies operator workflows, reduces training times, and enhances productivity. Operators wrap packages quickly and easily with the Step-Saver's ergonomic design.



Intuitive Software

The FreshBase Controller delivers enhanced integration by supporting communication with existing corporate applications through browser-based and web services technologies. Familiar FreshPro software provides ease of maintenance by enabling increased self-diagnostics accessible for in-store or remote servicing.



Maximum Durability

Designed to withstand the rigors of daily use, the FreshBase Controller, FreshTWP and Step-Saver Wrapping System combines connected components to offer a high 50 lb weighing capacity. The Step-Saver features a fully stainless steel design to enhance durability and hygiene, supporting uptime and food safety in your operations.



FreshBase Controller, FreshTWP and Step-Saver Combined Wrapping System

The METTLER TOLEDO FreshBase Controller, FreshTWP and Step-Saver Combined Wrapping System is designed for the prepacking needs of busy backroom departments. From the processing of packages too large to go through the automatic wrappers, to a secondary system for the busiest retailers, the system boosts backroom productivity and saves space while providing great value through its low cost of lifetime ownership.

- Rugged efficiency with stainless steel construction
- Versatility with 50 lb. weighing capacity
- Easy cleaning and open design
- Simple and fast loading of film rolls

Satisfying All Production Needs

The FreshBase Controller, FreshTWP and Step-Saver Combined Wrapping System is the perfect solution for all daily weigh, wrap and label needs. For larger retailers, it is an excellent system to handle peak shopping hours.



Technical Data

Step-Saver Hand Wrapping Station

Film Capacity

Two rolls, up to 20 in. (50.8 cm) wide

Film Type

PVC Stretch

Bottom Seal

Thermostat controlled sealing plate with nonstick cover

Film Cutting

Thermostat controlled low temp rod

Electrical

115 VAC
60 Hz, Single Phase 10 A
625 Watts (excluding scale and printer)

Construction

Stainless steel with folding shelves

System Weight

120 lb.

Operating Range

40° F - 95° F (5° C - 35° C)

Options

Stainless steel 12 in. x 24 in. platter shelves (left-right)
Universal swivel shelf (Standard)
Label dispenser rack
Commodity rack
Shelf support leg

Compatible Controller

FreshBase C3

FreshTWP

Capacity	50 lb
Single Interval	50 x 0.01 lb
nmax	5000

Part Numbers

30415622 - Step-Saver Hand Wrap Station
30555364 - FreshBase C3 Controller (needs configured)
30696910 - Fresh TWP50 Scale Base
30712833 - TWP50 / Hand Wrap Mounting Kit

Step-Saver Hand Wrapping Station shown with FreshBase Controller and shelf support leg configuration

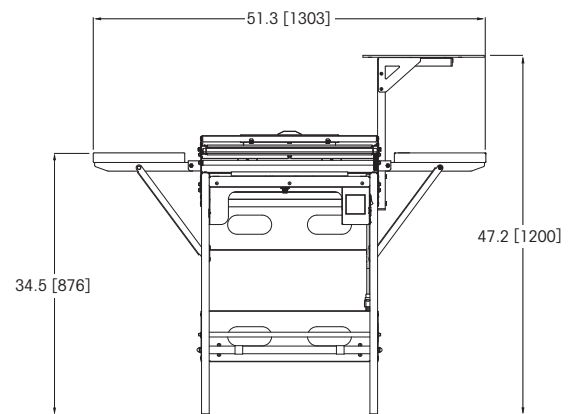
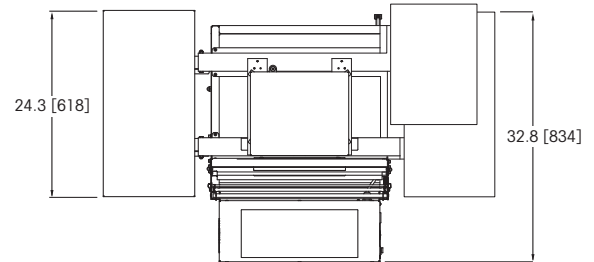

Dimensions in inches (mm)

METTLER TOLEDO Group

Retail Division
Local contact: www.mt.com/contacts

Subject to technical changes
©06/2022 METTLER TOLEDO. All rights reserved
Document No. 30577594 A
MarCom Industrial

www.mt.com/retail

For more information

