

Small Footprint Backroom Optimization



Easy to Use

With its intuitive touchscreen, the 840 Manual Label Printer guides employees quickly through the labeling process, reducing operator training time. More experienced operators can enter PLUs using the tactile numeric keypad for even faster results.



Fewer Label Roll Changes

Thanks to its large, 9 in. label roll capacity, the 840 Manual Label Printer requires fewer roll changes and achieves superior operational uptime. The easy-access, front-loading drawer allows roll changes to be completed quickly.



High-Performance Printer

Achieving a print speed of up to 150 mm/s, the 840 Manual Label Printer provides high-volume, weight-independent price labeling applications – whether in grocery backrooms or in deli stores for priced-by-count or by-weight items.



Streamlined Data Management

Round-the-clock access to real-time product and sales data is essential to manage fresh food items profitably. The 840 Manual Label Printer connects easily to the grocery retailer's ERP system to enhance its fresh food management – both in terms of tracking and traceability as well as back office connectivity.



840 Manual Label Printer Manual Weigh Price Labeler

The METTLER TOLEDO 840 Manual Label Printer is the ideal choice for grocery retailers who want to equip the meat backroom with a powerful label printer for price-by-weight and/or by-count packaged items. Integrate the 840 Manual Label Printer with the METTLER TOLEDO Step-Saver Hand Wrapping Station for an excellent alternate system to support larger items up to 60 lb. The 840 Data Management Software synchronizes with other METTLER TOLEDO 800 Series equipment, ensuring uniformity and conformity of all the data supplied to any wrapper system in the METTLER TOLEDO 800 Series.

- **Large label roll – longer production runs, higher operational uptime**
- **Easy to use – reducing operator training time**
- **Fast label printing – suitable for high-volume label printing**
- **Eye-catching labels – high-quality printing with custom graphics**

A One-Stop Shop for Backroom Optimization

METTLER TOLEDO supports grocery retailers throughout the entire lifetime of their backroom solutions – by advising on product decisions, installing and implementing the devices and systems, and providing maintenance and after-sales service as well as supplying consumables.



Technical data

840 Manual Label Printer

Applications

Manual label printing for price-by-weight or by-count items (scale included)
Manual weighing, wrapping* and labeling
Dual mode: Two label printers can operate with one scale

Print Speed

150 mm/s

Label Printer

Direct thermal print head

Weighing Platter

Stainless steel

Weighing Capacity

60 lb.

Operating Environment

23°F–104°F (-5°C–45°C)

Label Sizes

1.5 in.–3 in. width

1 in.–8 in. length

Label Roll

Inside diameter: 3 in.
Outside diameter: 9 in.

Power Supply

240 VAC, Single Phase
50–60 Hz, 4 A

RAM

34 MB

Operating System

Embedded Linux OS

Network Interface

Wired ethernet
Wireless upgrade available

Operator Interface

Adjustable 10.4 in. color LCD touchscreen panel with positive input response
Tactile keypad

* requires hand wrap station

For tray and film specifications associated to use with manual wrap station, please see Step-Saver Hand Wrapping Station specifications.

Dimensions in inches

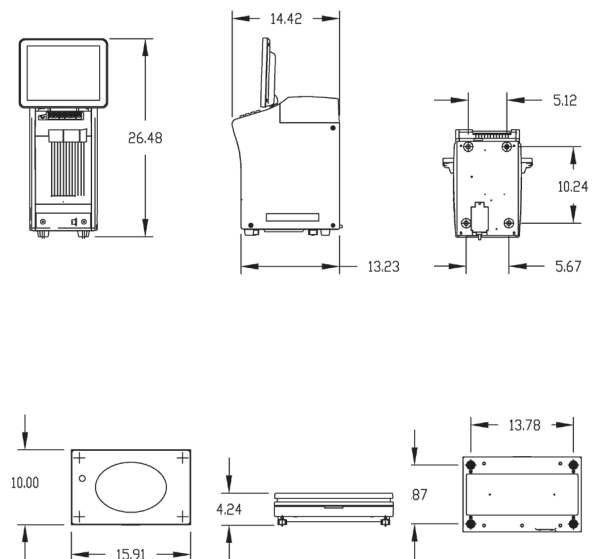

www.mt.com/retail

For more information



ISO 9001 quality management certification
ISO 14001 environmental management certification

Subject to technical changes.
© 09/2017 Mettler-Toledo, LLC
Printed in USA RDB024.1E
Global MarCom Switzerland / RT

