

Top Five Ways to Cheat a Truck Scale

How to Prevent it from Happening to You

Theft, forgery and credit card fraud. Those are all ways that criminals cheat the system for their own personal benefit. Unfortunately, those types of crimes have been prevalent for many years, therefore we know to look out for them.

What if you were the victim of a crime you didn't know to look for? What if you were getting robbed of your product, but in small enough increments that you did not notice right away? That is exactly what happened to a major international bulk goods manufacturer recently; it was robbed of \$2 million in product over several years, right from the truck scale.

This disturbing trend has been increasing in recent months and is now showing up in all parts of the world. Just as cyber criminals continue to innovate and outsmart the system, thieves at the truck scale are doing the same. Here we will take a look at the top five ways criminals steal from the truck scale and how METTLER TOLEDO can protect your business.



Contents

Cheat # 1: Improper Positioning

Cheat # 2: Load-Cell Tampering

Cheat # 3: Lighten the Load

Cheat # 4: Disappearing Goods

Cheat # 5: Altering Data

Conclusion

Cheat # 1: Improper Positioning

The most common way to cheat at the truck scale is also the simplest—improper positioning of the truck on the weighbridge. There are several scenarios that make this possible for a truck driver to accomplish.

1. At an unattended weigh station or a busy station at which the scale-house attendant is not paying attention, a truck drives onto the scale leaving a set of back axles off or pulls far enough forward that the front axles are past the scale. It is also possible, if guide rails are not in place on a pit foundation scale, that the truck is slightly off the side of the scale, also altering the weight. That provides a weight reading that is deceptively light. A driver may want to weigh light if he or she is the one purchasing your goods, essentially stealing product right from the scale.

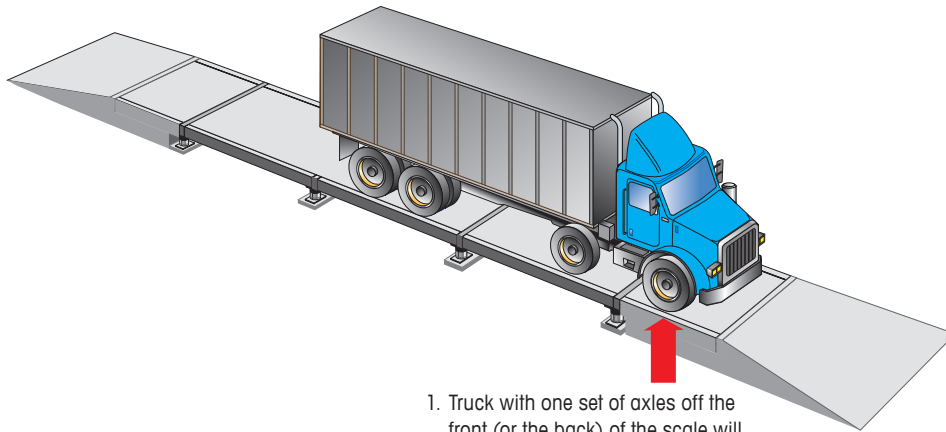

1. Truck with one set of axles off the front (or the back) of the scale will weigh lighter.

2. Another scenario can occur when a truck driver wants to weigh heavy, perhaps when selling to you. Again that can occur at unattended weigh stations or stations that are too busy for staff to police. A truck pulls fully onto the scale, with all axles on and creeps toward the very front of the weighbridge. A truck driver waiting next in line will then pull his front axles onto the scale, creating a deceptively high weight. The driver then gets the ticket for a net load that is more than what is received by the company, robbing the business and driving away unnoticed.

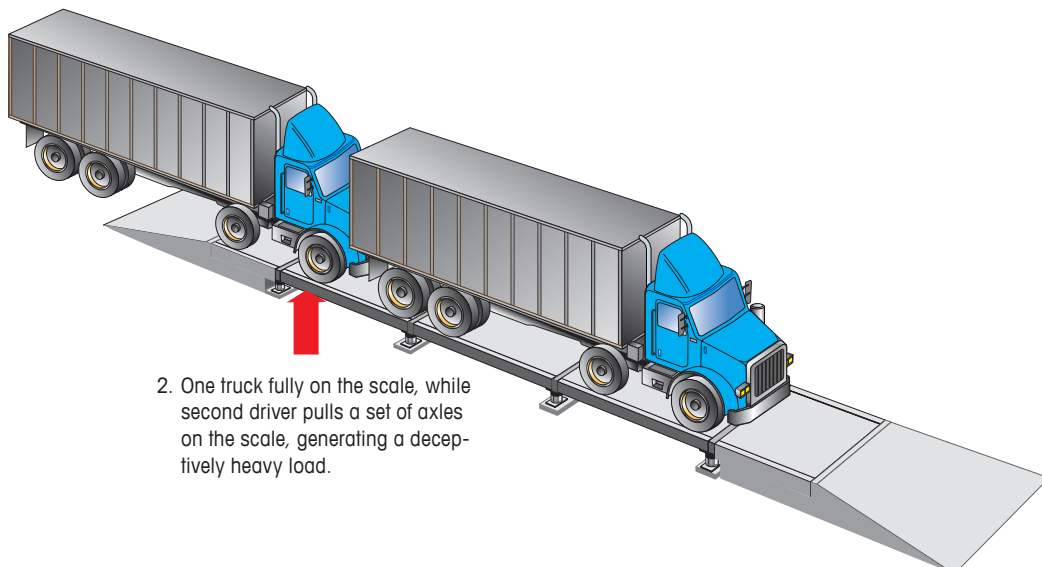

2. One truck fully on the scale, while second driver pulls a set of axles on the scale, generating a deceptively heavy load.

How Can METTLER TOLEDO Help Prevent Improper Positioning?

We offer a wide variety of solutions to help combat this cheat. With a few simple additions to a truck scale, thousands of dollars could be saved from would-be thieves.

1. **Gates, loops, photo eyes and more** – Those accessories can work together or individually to help stave off theft at the scale. Gates help to prevent more than one truck driving onto the scale, such as in scenario number 2 discussed on the previous page. Often, gates and loops will be paired together. Loops send a signal when a truck pulls onto the approach. When the scale is empty and ready to weigh, the gate will lift, allowing the truck to pull on. Photo eyes can detect this cheat, as well as improper positioning of a single truck. With photo eyes, a weight reading will not be taken if something is blocking the laser between the two eyes. Those are especially helpful for unattended weigh stations. License plate capture is another feature that is helpful to deter cheating; if drivers know they could be held accountable, they are less likely to attempt stealing at the scale.

2. **DataBridge™ MS Software** – Using transaction-management systems can help you to control inventory company-wide. The system identifies any discrepancies in inventory levels and notifies key users.

► www.mt.com/DataBridge

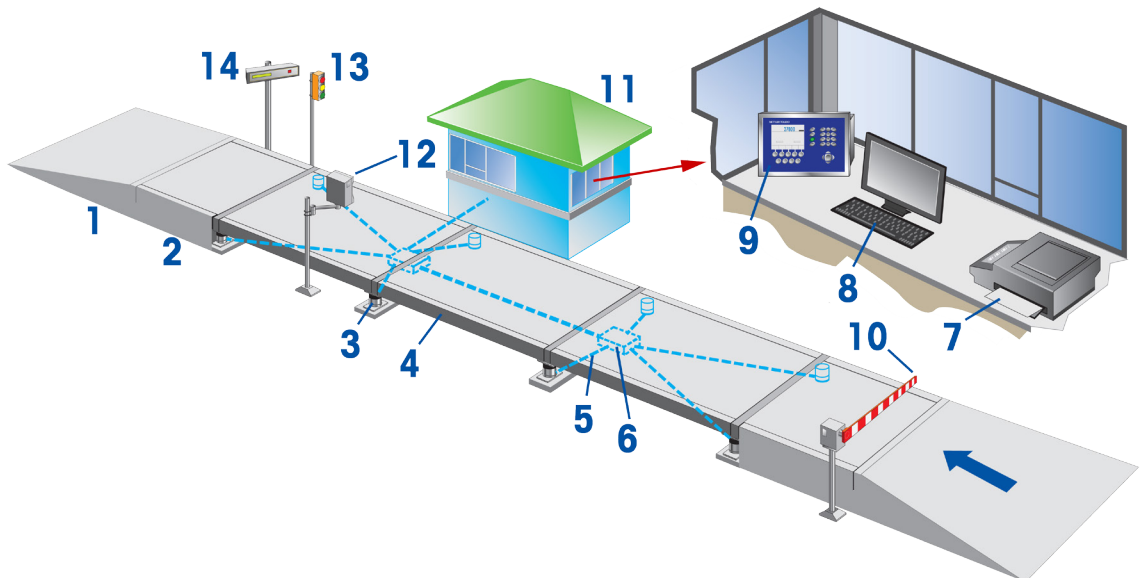

- | | | |
|--------------------|-----------------|--|
| 1. Ramp | 6. Junction box | 11. Scale house |
| 2. Approach | 7. Printer | 12. Unattended (self-service) terminal |
| 3. Load cell | 8. Computer | 13. Traffic control light |
| 4. Weighbridge | 9. Terminal | 14. Remote weight display |
| 5. Load cell cable | 10. Gate | |

Cheat # 2: Load-Cell Tampering

Unfortunately, tampering with load cells is becoming a popular way of cheating the truck scale. This cheat could go undetected for months before a scale operator is aware of the problem, costing the company thousands of dollars.

Load-cell tampering can involve tampering with the load cell itself, cables in the system or the junction box. Most commonly, a device is added at a point in the system, allowing the weight to be increased or decreased to the truck drivers' benefit. A greater concern is that those devices can be purchased online. Often that will occur with a driver who does business with the same operation regularly. The driver can return to the scale under the cover of night, affix the device to the scale and cheat until the device is discovered.

Pictured below, these small remotes can control how the weight is read while the truck is on the scale. Once the driver has driven onto the scale, he can push the clicker up or down to his benefit (heavier or lighter) just before the weight reading is taken. Analog load cells are particularly susceptible to this type of scam, as they do not have a breach-detection system to alert scale owners that tampering or damage has occurred, unlike some digital load cells.

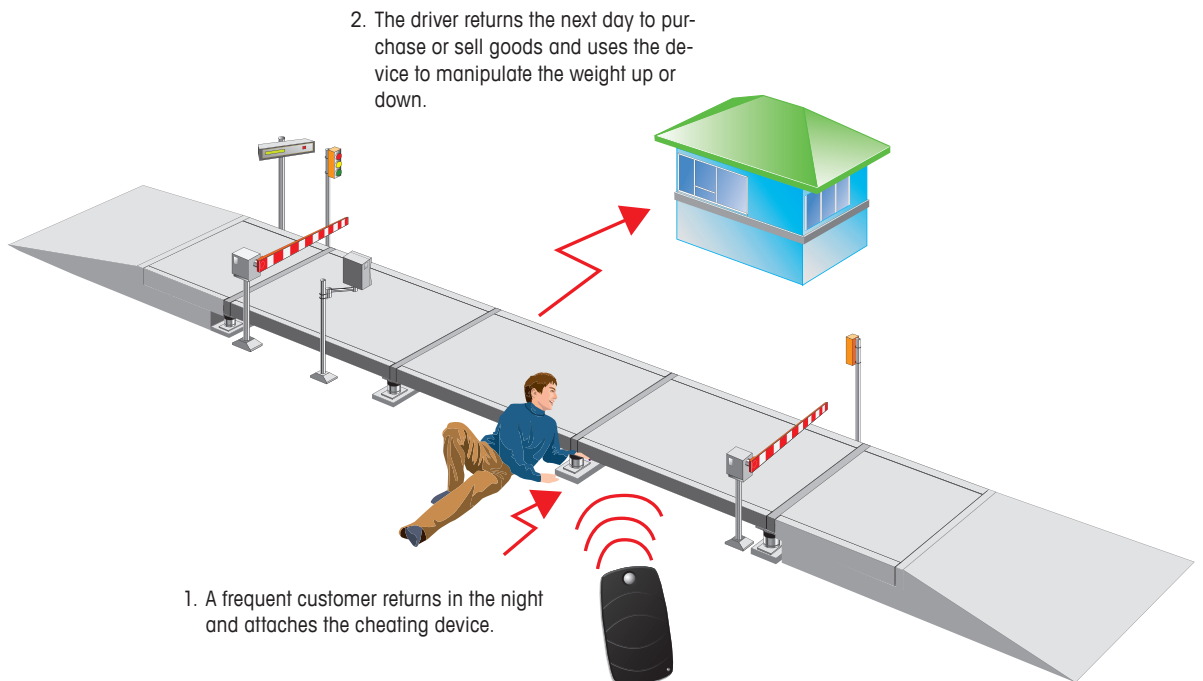

How Can METTLER TOLEDO Help You Prevent Load-Cell Tampering?

With analog load cells and an ineffective data-management system, a theft due to load-cell tampering could go undetected for months. And once discovered, it is very unlikely that the person responsible will ever be caught; in fact, the cheater will probably continue to do business with the company.

With superior POWERCELL® PDX® technology and DataBridge™ software management, it is easy to outsmart criminals at the scale. POWERCELL PDX load cells with secure breach-detection technology alert the scale owner at the first sign of tampering or damage, and can even pinpoint the cell that has been compromised. That immediate alert will help to stop theft due to tampering before it ever begins. Pair POWERCELL® technology with DataBridge for system-wide security monitoring and mobile alerts. Additionally, unlike analog load cells, the signal for these advanced load cells is encrypted, making the data cheat proof.

An additional feature of DataBridge™ MS software is the weight curve function. That feature allows the scale-house attendant to watch in real time the weight of the truck as it is driving onto the scale, and as it stops to have a weighment taken. A normal weight reading should look like a bell curve that flattens at the top when the truck is stopped. Any abnormal spike up or down in weight will stand out, prompting the scale-house attendant and any other key players to review the weighment and check the scale.

- ▶ www.mt.com/DataBridge
- ▶ www.mt.com/powercell

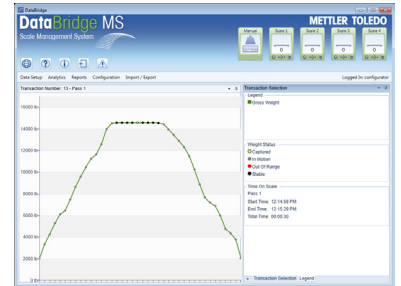

Normal weight curve.

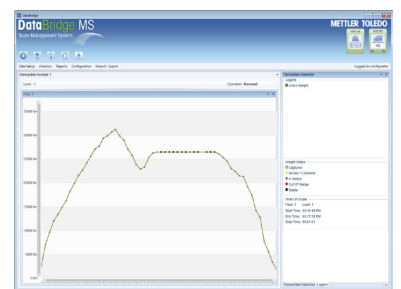

Weight curve that has been tampered.

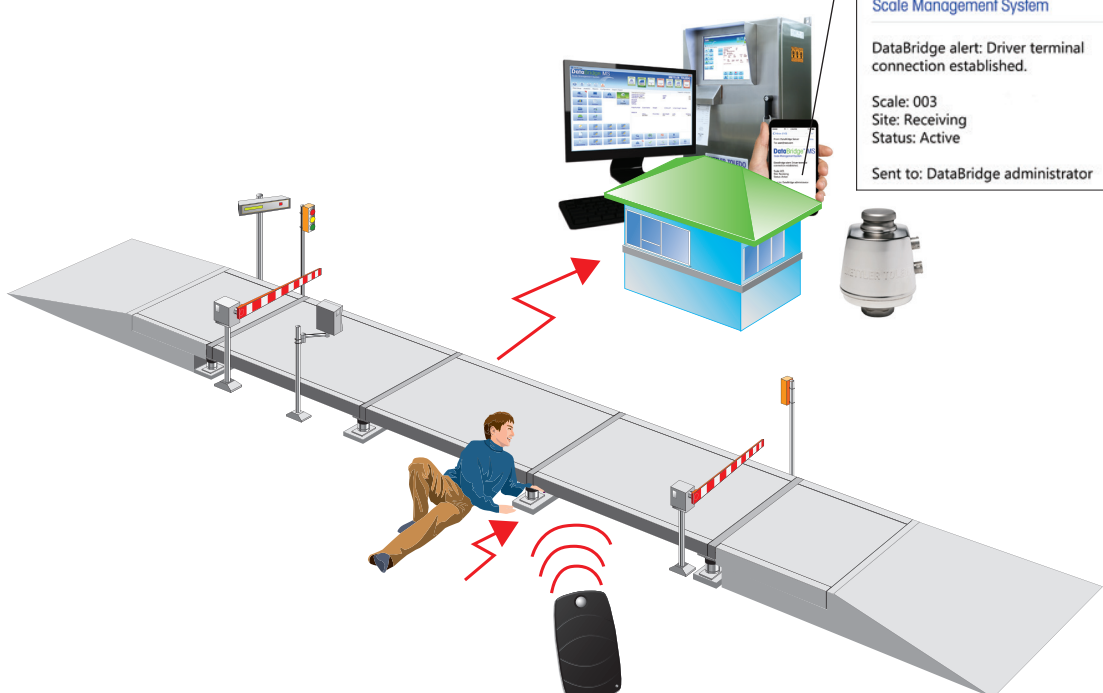

ALERT NOTIFICATION

From: DataBridge Server Hide

To: user@test.com

DataBridge™ MS

Scale Management System

DataBridge alert: Driver terminal connection established.

Scale: 003
Site: Receiving
Status: Active

Sent to: DataBridge administrator

Cheat # 3: Lighten the Load

This cheat at the scale is a good example of how thieves are becoming more innovative. It is most common at sites with two-pass transactions and when there is some distance between the scale and where loading or unloading occurs.

- 1. Delivery Cheat:** A driver will arrive with a fully loaded truck, take an initial weight and then drive to the site where the goods are unloaded. Once out of sight of the scale house, the driver expels additional weight that was hidden on the truck to increase the initial weighment. Commonly, a bladder of water is kept in the cab. Additionally, there might be another passenger in the cab that gets out, walks to the entrance and waits to be picked up. At that point, the driver could have expelled an additional 400 pounds (150 pounds of water dumped and 250 pounds of passenger walking to exit) from the truck.

Result: Now, the driver will go back to the scale house and take the outbound weight. The net weight (gross minus tare) will read 400 pounds more than it really was, and the driver will get paid for 400.

Welcome Please Weigh In

1. Driver arrives full and takes initial weight, storing extra weight in the cab.

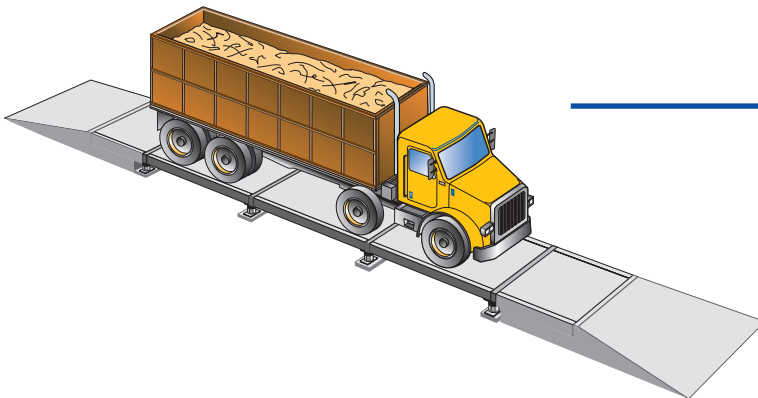

Weight of Water		
A	1 Gallon	8.35 pounds
	18 Gallon	150 pounds
B	1 Liter	1.0 Kg
	70 Liters	70 Kg

2. Driver proceeds to sight where goods are delivered.

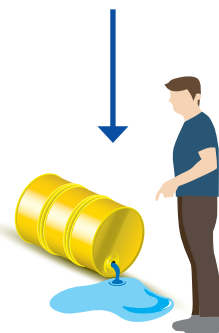

Thank You Please Take Final Weight

4. Driver takes final weight and is paid for more product than what was delivered.

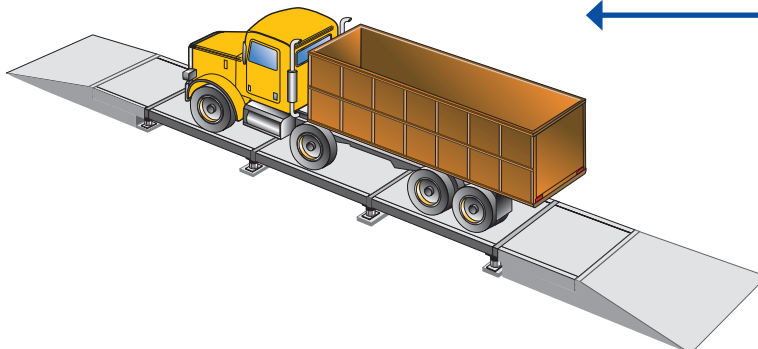

3. Once out of sight driver dumps bladder of water and additional passenger exits the cab.

2. **Pick-Up Cheat:** A driver will arrive with an empty truck, take an initial weight and then drive to the location on site to be loaded. Once out of sight of the scale house, the driver expels additional weight that was hidden on the truck to increase the initial tare weighment. Again, it is common that a bladder of water is kept in the cab to dump or an additional passenger exits to the front gate. The driver could have expelled an additional 400 pounds (150 pounds of water dumped and 250 pounds of passenger walking to exit) from the truck, creating a tare (empty) weight that was 400 pounds higher than the true weight of the truck.

Result: Once loaded, the driver will go back to the scale house and take the outbound weight. The truck's tare, or empty weight is recorded as 400 pounds heavier due to the cheat. The driver will receive 400 pounds of goods that were not paid for.

This theft at the scale could repeatedly go undetected without the proper protection.

Welcome Please Weigh In

1. Driver arrives empty, but is storing extra weight.

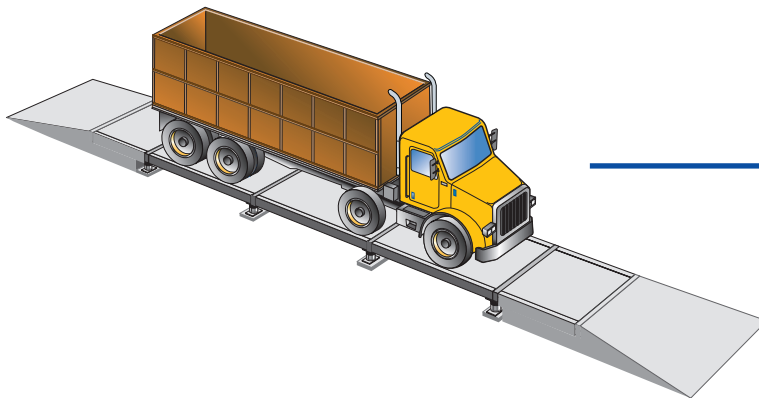

2. Driver proceeds to the location where they are loaded with product.

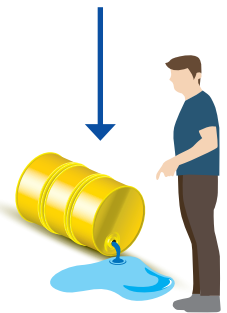

Thank You Please Take Final Weight

4. Driver receives 400 pounds of product that was not paid for, due to deceptively high tare weight.

3. Once out of sight driver dumps bladder of water and extra passenger exits the cab.

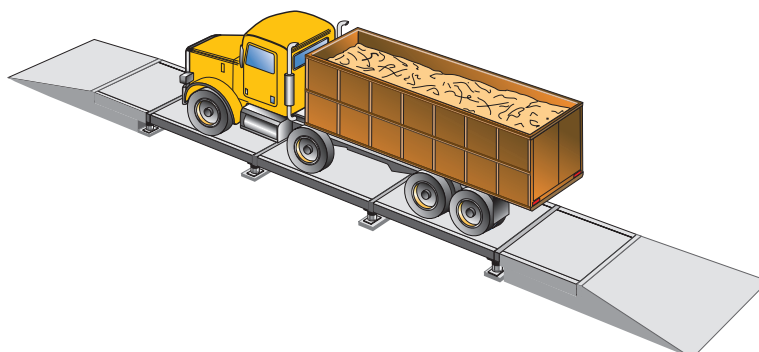

How Can METTLER TOLEDO Help Combat "Lightening the Load" Cheat?

METTLER TOLEDO can help to combat the "lighter load" cheat with DataBridge™ MS technology. This data-management program has hundreds of features, but one that can be helpful in this scenario is tare-weight storage. When a truck arrives at the business operation for the first time, all information about that truck is recorded, including an accurate tare weight. Business owners can set up regular or random tare-weight checks. If any abnormal fluctuation in tare-weight has occurred for a truck that is rechecked, the scale-house attendant and any other key account holders will be notified. An additional feature with DataBridge™ MS is the option to set a time limit for how long the driver has between the first and second weighment. If the time limit is surpassed, the driver will be flagged and questioned by the scale house staff. Perhaps the driver simply got a new set of tires or was stuck waiting in line to be emptied—or maybe the driver was trying to cheat the scale. With DataBridge™ software, you can be sure with every load.

- ▶ www.mt.com/DataBridge
- ▶ www.mt.com/powercell

Welcome Please Weigh In

1. Driver arrives (full or empty) and weighs in, secretly storing extra weight that will be dumped.

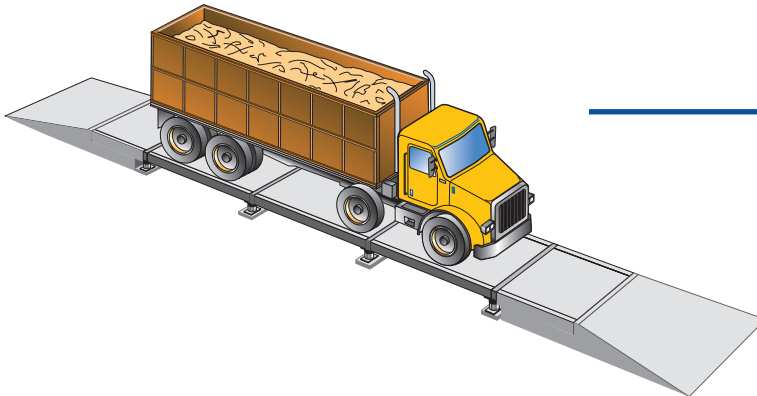

2. Driver delivers or picks up the goods.

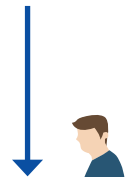

Time limit is surpassed!

4. DataBridge™ set a time limit for how long the driver has between the first and second weighment.



3. Drivers dumps the bladder of water and passenger exits the cab.

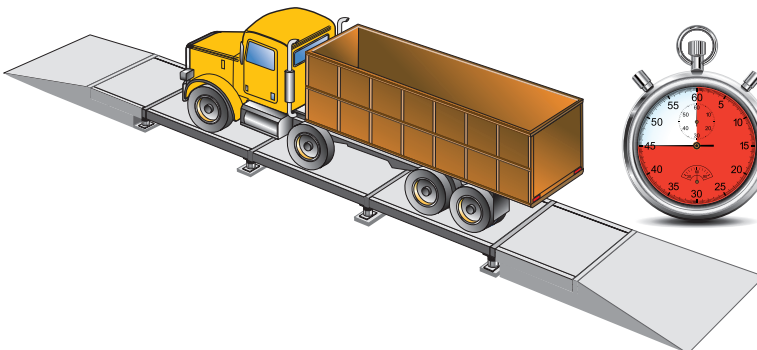

Cheat # 4: Disappearing Goods

This cheat at the scale is most common at companies that have a dedicated fleet of trucks that run the same route all day. It is most easily explained through an example.

A company that makes luxury countertops has a factory 30 miles away from the closest quarry where it sources raw materials. Four trucks run the route five times per day. Each time, they buy 20 tons of river stone pebbles at \$100 per ton. Each trip costs the company \$2,000.00 for the full truckload it has purchased.

Two truck drivers decide they deserve a raise, so they begin to steal a small amount of product from each load. In order to not get caught, they steal only 300 pounds from each loaded truck, dumping it in a secret location they can return to later. Stealing this small amount will only make each driver about \$375 per week, a seemingly small amount. However, after one year (50 working weeks), it adds up to \$18,750. That's a cost to the company of nearly \$37,500 between the two drivers. If all four truck drivers decide to participate in the crime, the company would lose \$75,000 over one year.

Imagine that on a larger scale or with a more expensive product and the costs can add up quickly. Are you willing to sit back and allow others to steal from your business?

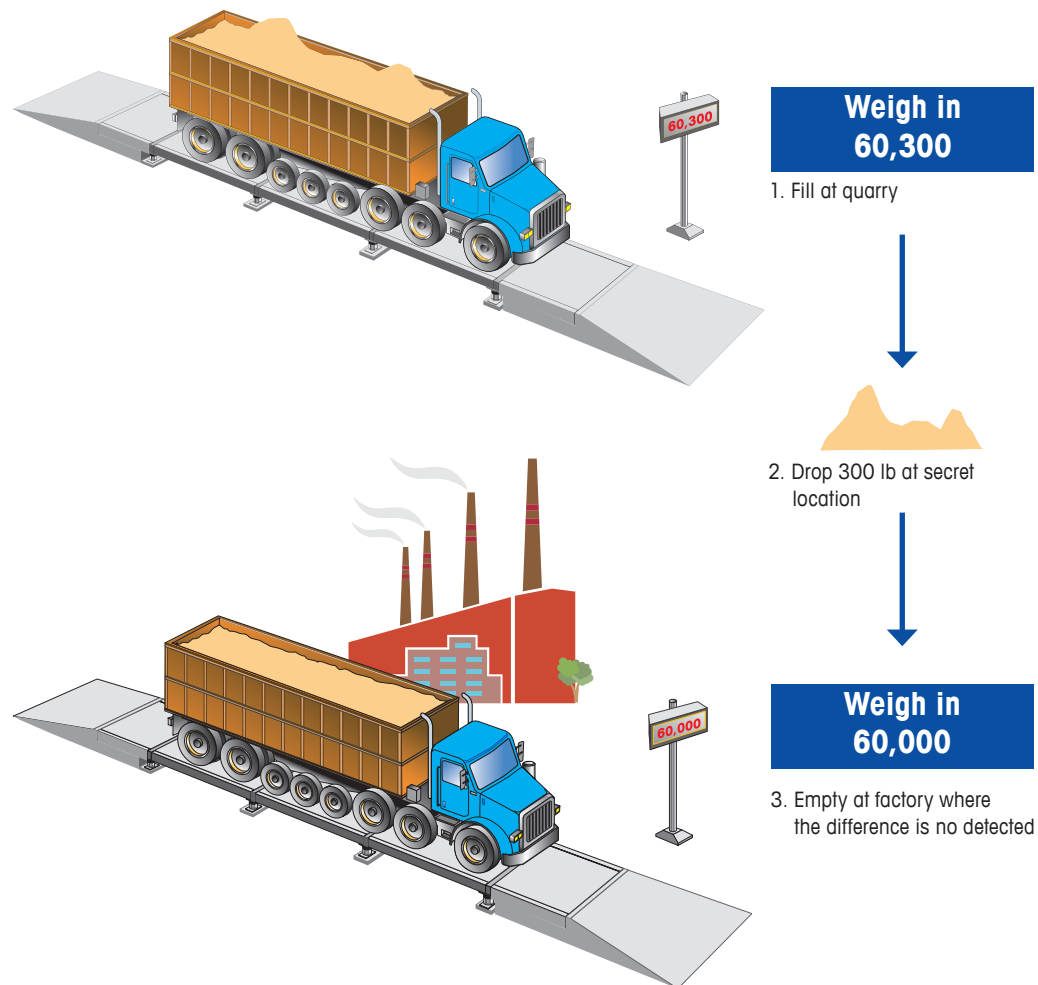

How Can METTLER TOLEDO Help Combat Disappearing Goods?

With METTLER TOLEDO, the solution to the disappearing goods cheat is simple: accurate weighing! With a truck scale at both the quarry and the factory, there would be no room for theft at the scale. POWERCELL® PDX® technology provides industry-leading accuracy and gives any business confidence that the weight taken is the true weight.

When paired with DataBridge™ software, the communication between the quarry and factory is instant. If a driver is weighed at the quarry and then arrives at the factory 300 pounds lighter, you would notice the difference immediately. That kind of assured accuracy is a valuable theft deterrent.

- ▶ www.mt.com/DataBridge
- ▶ www.mt.com/powercell

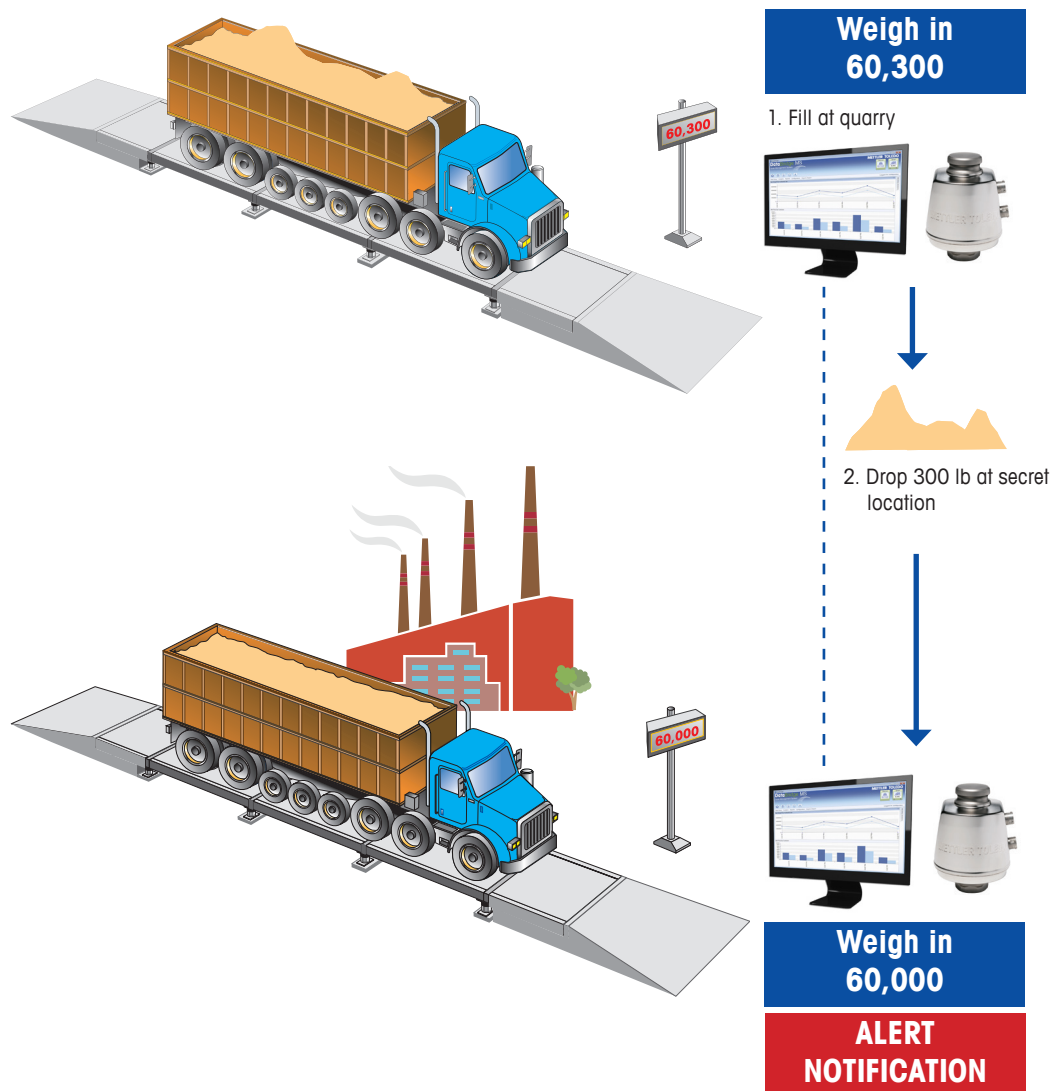

Cheat # 5: Altering Data

The final cheat that has been most observed in the field is perhaps the most direct: the intentional altering of data collected at the scale. There are a couple scenarios in which that can happen, and they are of equal concern to a business owner and operator.

1. A scale-house attendant works with one or more drivers to alter data to the drivers' benefit, and the attendant then gets a cut of the profits. Some small operations rely on hand-written tickets for transactions. As you can imagine, these are especially easy to alter maliciously and by mistake. While that may seem unlikely, it happens and can add up at an alarming rate. In fact, not long ago, a major bulk goods manufacturer in the U.S. was robbed of \$2 million worth of product over a period of a couple years—all at the hands of a scale-house attendant working with several drivers to alter their weigh tickets. Company leaders thought their systems were secure, which serves to prove that truck-scale fraud can happen to anyone.

2. Another variation of data altering can occur if the data-management software used is insecure and susceptible to hacking. Often, free programs are less secure and can easily be accessed from the back-end by hackers, going undetected in most cases.



How Can METTLER TOLEDO Help Combat Altering Data?

DataBridge™ MS Software by METTLER TOLEDO is the answer to all data-altering cheats at the scale. A secure system that is not vulnerable to hacking is critical for your business. Additionally, any data altering that is done within the system will be tracked. If a scale-house attendant alters data for malicious reasons, the software documents it. Knowing those actions could cost employees their jobs is an effective deterrent to these crimes.

► www.mt.com/DataBridge



Conclusion

Criminals have been using these tactics for years to cheat at the truck scale. They have stolen innumerable amounts of product and profits from companies all over the world. This crime is growing rapidly and is surprisingly easy to accomplish, especially when little has been done to prevent it. Fortunately, fraud prevention solutions from METTLER TOLEDO can ensure that your company is protected.

Don't sit back and let criminals take advantage of the business you have built. Visit www.mt.com/vehicle to get everything you need to stop crime at the scale.

www.mt.com/vehicle

For more information

Mettler-Toledo AG
Industrial Division
CH-8606 Nänikon, Switzerland

Local contact: www.mt.com/contacts

Subject to technical changes
© 11/2015 Mettler-Toledo AG
30259870