

# Floor Scales



## **2888 DECKMATE®**

Portable Floor Scale

Ultra-Low Profile

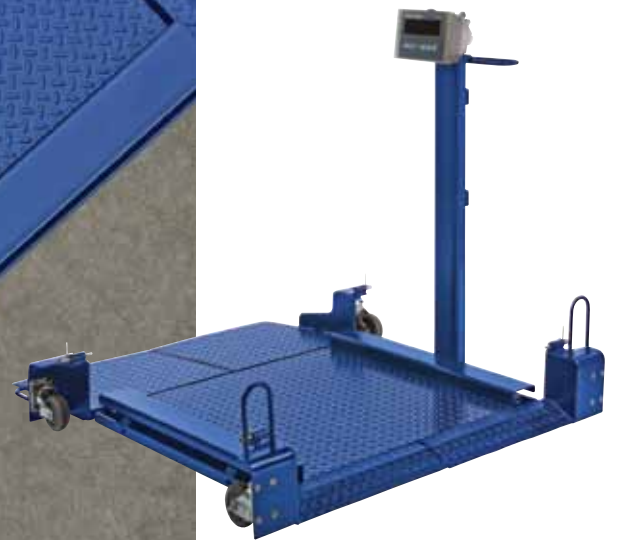

**Portable Scale Goes Anywhere,**  
Handles Any Environment

**METTLER TOLEDO**

# Low-Profile Scale for Batching and Filling in Harsh or Sanitary Environments

- **Ultra-low profile for easy loading**
- **Hermetically sealed stainless steel load cells**
- **Scale engine provides precise, repeatable performance**

The 2888 DECKMATE floor scale is a portable scale with an extremely low profile for easy loading. This feature makes it ideal for weighing drums, totes, small mixing vats, and reactors. The scale can be used in harsh or sanitary environments such as chemical, petrochemical, pharmaceutical, and food processing operations.

Several sizes and capacities are available. The smallest version is sized for carts, drums, and small totes. The largest will accommodate large totes, IBC containers, and full-size reactors used in the petrochemical and pharmaceutical industries.

## **Portable**

The DECKMATE floor scale can be used as a static scale or equipped for maximum portability. The portable version has large caster wheels. Setup is quick and easy. Simply move the scale where you want it, lower the ramps, and start weighing. The 30x30-inch size fits easily through standard 36-inch doorways. For maximum portability, use the scale with a battery-

operated terminal—no electrical outlet is needed.

## **Safe**

Our standard tread-plate surface offers safe footing for workers. The scale's low profile means that less effort is required to manually place a load on the scale.

## **Sanitary**

The DECKMATE design eliminates hard-to-reach corners, gaps, and other areas where contaminants collect. Our glass-bead surface preparation provides a finish that resists scratching and chemical staining. It is also one of the easiest surfaces to clean. That is why most major pharmaceutical and food companies have adopted this scale as a standard.

## **Hazardous Areas**

Our load cells are approved for use in hazardous areas in most markets. DECKMATE load cells carry Factory Mutual, European Ex, and Canadian CSA Ex approvals when used with a METTLER TOLEDO intrinsically safe terminal.



Stainless steel DECKMATE floor scale for sanitary applications.

## Technology Does Make a Difference

Your scale needs to do more than give an accurate weight reading when it's brand new. It needs to give accurate readings time after time, even when used for demanding applications in industrial environments. How do we ensure this high level of performance? METTLER TOLEDO believes that technology is the key. We combine innovative designs with the manufacturing capabilities to turn those designs into precision products. We start with four goals in mind:

- The load cells must provide accurate, repeatable performance
- The design must protect the load cells from damage
- The suspension system must ensure vertical loading
- The scale must be designed for durability

At the heart of each scale is our VERTEX® Scale Engine. It consists of the load cells and the suspension system that transmits weight from the platform to the load cells. We design scale components to perform reliably, without the need for adjustment. And we test our products extensively to ensure that you get a scale you can count on. Take a look at what makes our scales different:

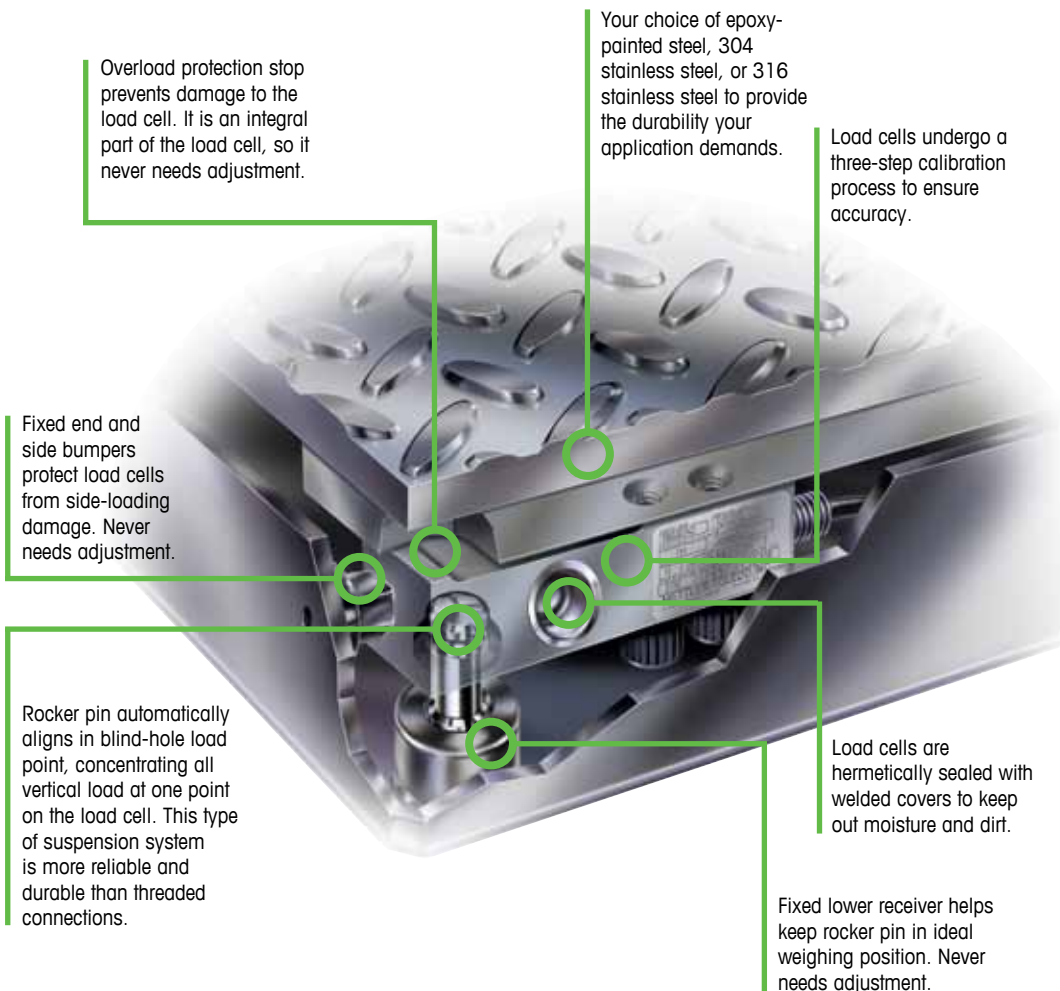

Choose from 304 or 316 stainless steel for the level of corrosion resistance you need.



Portable 30x30-inch scale fits easily through standard doorways. Hinged ramps fold out of the way when scale is moved or stored.



Ultra-low profile makes it easy to wheel heavy containers onto the scale.

## Specifications

Standard Platform Size Static Version	24x24 to 48x60 inches (610x610 to 1219x1524 mm)
Standard Platform Size Portable Version	24x24 to 42x42 inches (610x610 to 1067x1067 mm)
Available Capacities Static Version	500 to 5000 lb (300 to 3000 kg)
Available Capacities Portable Version	500 to 2500 lb (300 to 1500 kg)
Platform Height	1.5 to 2.5 inches (38 to 63 mm)
Standard Construction	Two-part, epoxy-painted carbon steel, 304 stainless steel, or 316 stainless steel
Load Cell Type	Four 350-ohm load cells; hermetically sealed stainless steel
Load Cell Suspension	Stainless steel rocker-pin assembly
Junction Box	Top access, stainless steel IP69K
End Loading	100% end loading
Standard Operating Temp.	14°F to 104°F (-10°C to 40°C)
Metrological Approvals	NTEP, Measurement Canada, OIML
Hazardous Area Approvals	FM, CSA, Ex, ATEX
Shipping Weight Static Version	125 to 540 lb (57 to 245 kg)
Shipping Weight Portable Version	520 to 740 lb (236 to 336 kg)
Compatible METTLER TOLEDO Instruments	Most METTLER TOLEDO terminals

## Portability Configuration - Additional Features

Portability Frame Outer Dimensions	27.5x43.625 to 45.5x63.0 inches (699x1108 to 1156x1600 mm)
Instrument Column	37.5 in. (953 mm) high - Included standard with portability option
Accessory Mounting Plate	Pre-tapped holes for mounting METTLER TOLEDO battery pack or hazardous area power supply

## Options

- Ramps: 4.5", 12", 18" long
- Instrument mounting brackets
- Portability conversion kits

[www.mt.com/floorscale](http://www.mt.com/floorscale)

For more information

### Mettler-Toledo, LLC

1900 Polaris Parkway  
Columbus, Ohio 43240  
Tel. (800) 786-0038  
(614) 438-4511  
Fax (614) 438-4900

Specifications subject to change without notice.  
© 2019 Mettler-Toledo, LLC

10/2019  
30129963



Produced in a  
facility that is

