

Guide for installers

METTLER TOLEDO MultiRange Explosion-protected weighing system with PSU power supply unit

METTLER TOLEDO

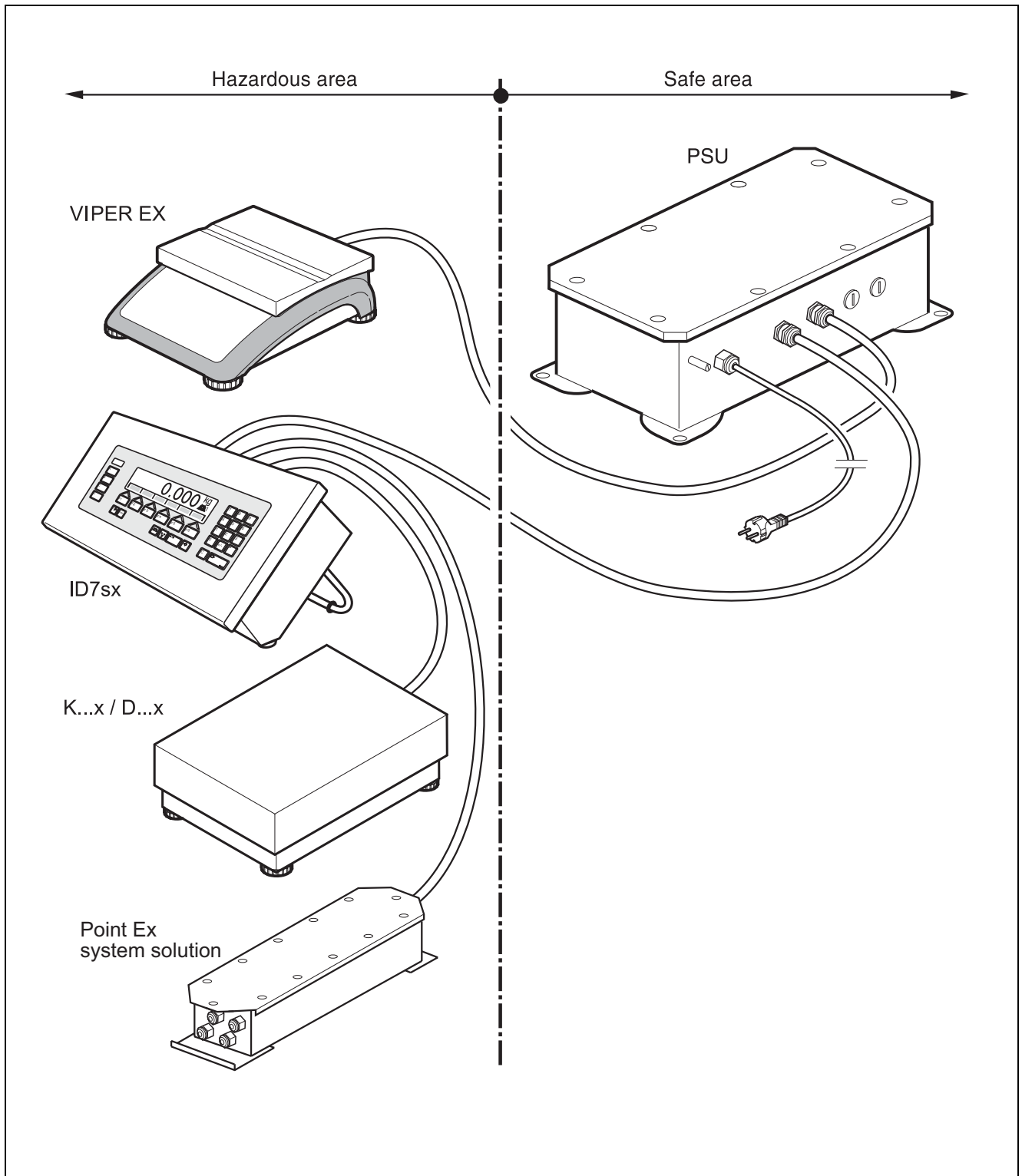

Contents		Page
1	Safety instructions	2
2	System overview	3
2.1	Typical configurations	3
2.2	Description of the components	6
3	Installation	7
3.1	Setting up system modules	7
3.2	Equipotential bonding	8
3.3	Connecting power supply	8
4	Optional work	9
4.1	Mounting verification bracket	9
4.2	Fabricating weighing platform cables	10
4.3	Installing additional scale interface	11
4.4	Installing data interface	13
4.5	Setting operating mode on CL20mA-PSU module	14
5	Technical data and accessories	15
5.1	Technical data of PSU	15
5.2	Technical data of RS232-PSU module	16
5.3	Technical data of CL20mA-PSU module	17
5.4	Accessories	18
6	Control drawings	20

1 Safety instructions



The PSU power supply unit is approved for the supply of weighing systems in zone 1 and 21 hazardous areas.

Particular care is required when using weighing systems with the PSU power supply unit in hazardous areas. The code of practice is oriented to the "Safe Distribution" concept drawn up by METTLER TOLEDO.

- Competence** ▲ The weighing system may only be installed, maintained and repaired by authorised METTLER TOLEDO service personnel.
- Ex approval** ▲ No modifications may be made to the terminal and no repair work may be performed on the modules. Any weighing platform or system modules that are used must comply with the specifications contained in the installation instructions. Non-compliant equipment jeopardises the intrinsic safety of the system, cancels the Ex approval and renders any warranty or product liability claims null and void.
- ▲ The safety of the weighing system is only guaranteed when the weighing system is operated, installed and maintained in accordance with the respective instructions.
- ▲ Also comply with the following:
- the instructions for the system modules
 - the regulations and standards in the respective country
 - the statutory requirement for electrical equipment installed in hazardous areas in the respective country
 - all instructions related to safety issued by the owner
- ▲ The explosion-protected weighing system must be checked to ensure compliance with the requirements for safety before being put into service for the first time, following any service work and every 3 years, at least.
- Operation** ▲ Prevent the build-up of static electricity. Always wear suitable working clothes when operating or performing service work in a hazardous area.
- ▲ Do not use protective coverings for the device.
- ▲ Avoid damage to the system components.
- Installation** ▲ Only install or perform maintenance work on the weighing system in the hazardous areas if the following conditions are fulfilled:
- if the intrinsically safe characteristic values and zone approval of the individual components are in accord with one another
 - the owner has issued a permit ("spark permit" or "fire permit")
 - the area has been rendered safe and the owner's safety co-ordinator has confirmed that there is no danger
 - the necessary tools and any required protective clothing are provided (danger of the build-up of static electricity)
- ▲ The certification papers (certificates, manufacturer's declarations) must be present.
- ▲ Lay cables in such a way that they are protected from damage.
- ▲ Only route cables into the housing of the system modules via the suitable cable gland and ensure proper seating of the seals.

2 System overview

2.1 Typical configurations

The following represents 3 typical configurations of a weighing system with the PSU power supply unit. The PSU power supply unit may only be installed in the safe area. The configurations presented can be combined as desired.

2.1.1 PSU, ID7sx weighing terminal and max. 3 weighing platforms

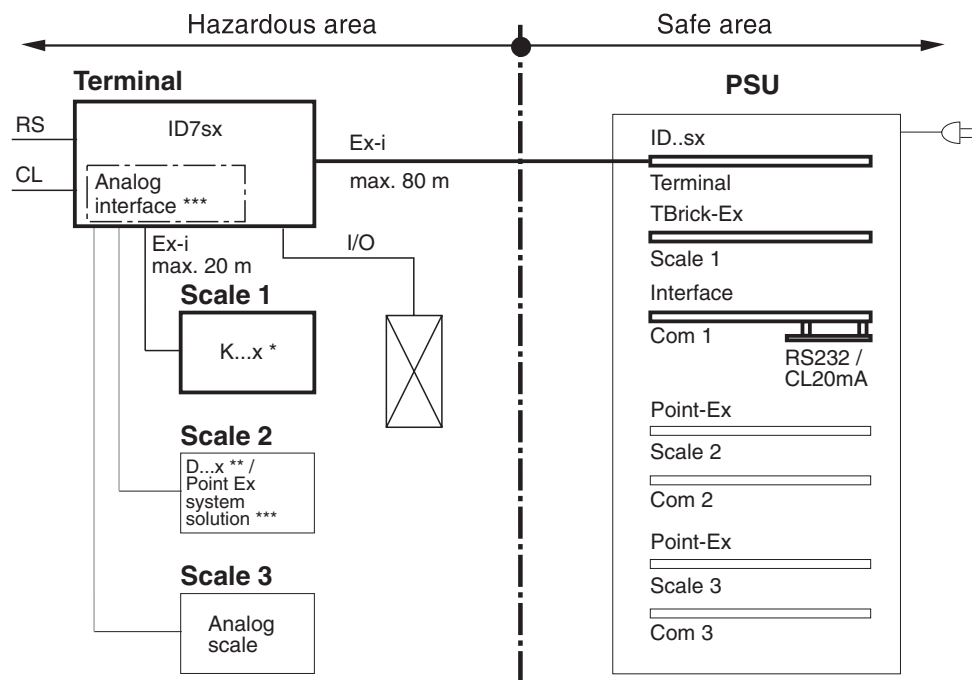

- * Only K...x weighing platforms with a TBrick...-Ex measuring cell are permissible in this configuration.
- ** D...x weighing platforms with in-built Point Ex A/D converter.
- *** Minimum supply impedance 87 Ω in conjunction with Slotcard Point-Ex.
Minimum supply impedance 250 Ω in conjunction with Slotcard TBrick-Ex.

2.1.2 PSU and max. 3 VIPER EX compact scales

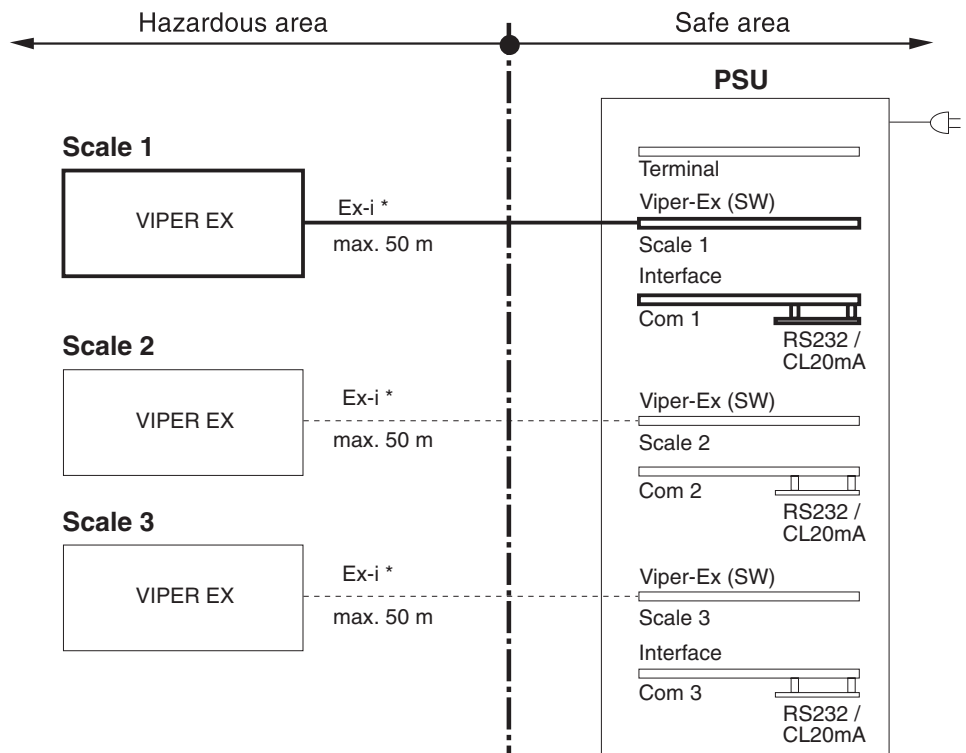

2.1.3 PSU and max. 3 D...x or K...x weighing platforms or Point Ex system solution

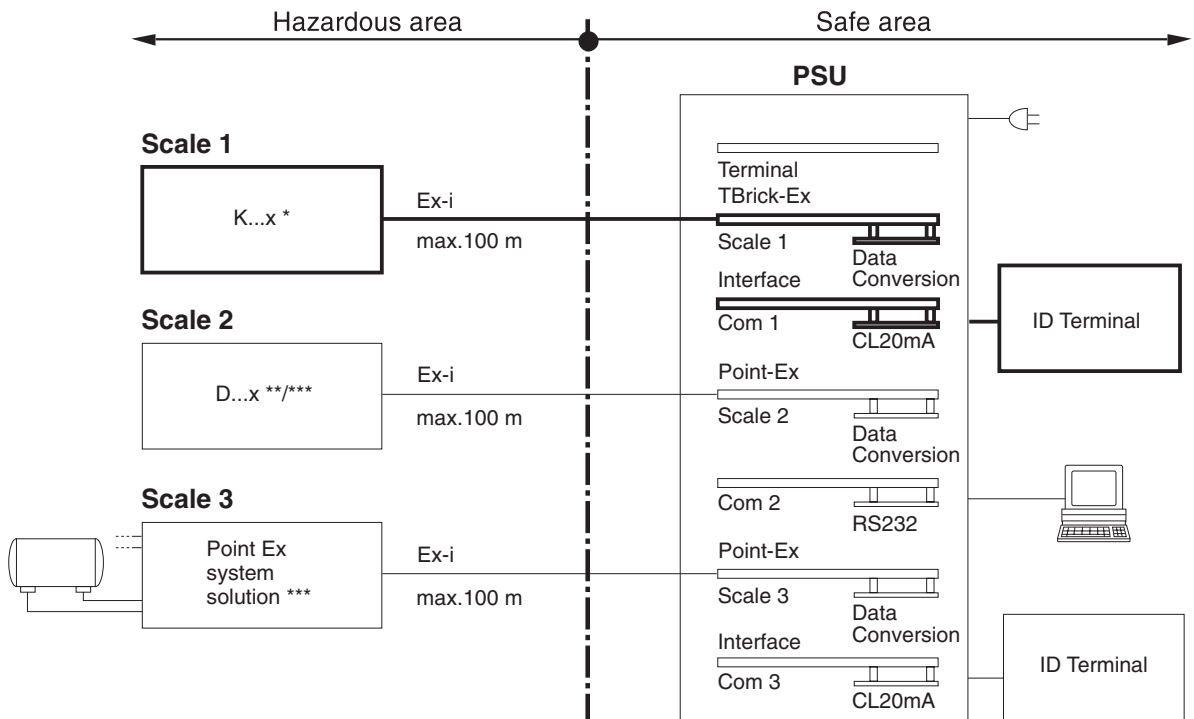

- * Only K...x weighing platforms with a TBrick ..-Ex measuring cell are permissible in this configuration.
- ** D...x weighing platforms with in-built Point Ex A/D converter.
- *** Minimum supply impedance 87 Ω in conjunction with Slotcard Point-Ex.
Minimum supply impedance 250 Ω in conjunction with Slotcard TBrick-Ex.

Note

When used in compulsory-verification operation in this configuration, the plugs to the weighing terminal and PC must be secured via the verification bracket. See Section 4.1.

2.2 Description of the components

PSU power supply unit	Type of protection	EN II (2) G, D [EEx ib] II C FM related electrical equipment with intrinsically safe outputs; Class I, II, III; Division 1; Group A, B, C, D, E, F, G
	Temperature range	−10 °C to +40 °C
Slotcard ID..sx	Type of protection	EN II (2) G, D [EEx ib] II C FM related electrical equipment with intrinsically safe outputs; Class I, II, III; Division 1; Group A, B, C, D, E, F, G
	Temperature range	−10 °C to +40 °C
Slotcard TBrick-Ex, Slotcard Point-Ex, Slotcard Viper-Ex (SW)	Type of protection	EN II (2) G, D [EEx ib] II C FM related electrical equipment with intrinsically safe outputs; Class I, II, III; Division 1; Group A, B, C, D, E, F, G
	Temperature range	−10 °C to +40 °C
Slotcard interface	Type of protection	EN II (2) G, D [EEx ib] II C FM related electrical equipment with intrinsically safe outputs; Class I, II, III; Division 1; Group A, B, C, D, E, F, G
	Temperature range	−10 °C to +40 °C
ID7sx weighing terminal	See operating instructions/guide for installers of ID7sx weighing terminal.	
Weighing platforms K...x / D...x	See operating instructions/installation instructions of the K...x and D...x weighing platforms.	
Compact scale VIPER EX	See VIPER EX operating instructions.	
Point Ex system solution	See Point Ex guide for installers.	

3 Installation



EXPLOSION HAZARD

The explosion-protected weighing system must be installed in accordance with the terminal diagram at the end of this guide for installers.

3.1 Setting up system modules

3.1.1 Setting up ID7sx weighing terminal

See guide for installers of ID7sx weighing terminal.

3.1.2 Setting up K...x / D...x weighing platforms

See K...x / D...x installation information.

3.1.3 Setting up Point Ex system solution

See Point Ex guide for installers.

3.1.4 Setting up VIPER EX compact scale

See VIPER EX operating instructions.

3.1.5 Setting up PSU

SAFETY PRECAUTIONS

- ▲ Only set up the PSU in a safe area.
- ▲ Ensure a sufficient air supply.

Fixed installation

1. Remove levelling feet.
2. Guide 4 M6 screws through holes of tabs and screw them into supporting surface (for a drilling diagram, see Section 5.1).
3. Extend mains cable if necessary.

Mobile installation

- Depending on the operating specifications, use a mains cable that is more mechanically rugged than the cable mounted at the factory.

3.1.6 Connecting power supply unit

- Connect the power supply unit to the system components in accordance with the respective terminal diagram.

3.2 Equipotential bonding

Equipotential bonding must be installed by an electrician authorised by the owner. METTLER TOLEDO Service only has a monitoring and consulting function here.

- Connect equipotential bonding (PA) of all devices (PSU, weighing terminal and weighing platform, compact scale) in accordance with the terminal diagram and the country-specific regulations and standards. In the process it must be ensured that
 - all device housings are connected to the same potential via the PA terminals
 - no circulating current flows via the cable shielding for intrinsically safe circuits
 - the neutral point for equipotential bonding is as close to the scale as possible

3.3 Connecting power supply



EXPLOSION HAZARD

The mains connection must be made by an electrician authorised by the owner in accordance with the terminal diagram and the country-specific regulations.

Note

The PSU power supply unit has no device of its own for mains disconnection. This must be provided by the owner.

4 Optional work

4.1 Mounting verification bracket

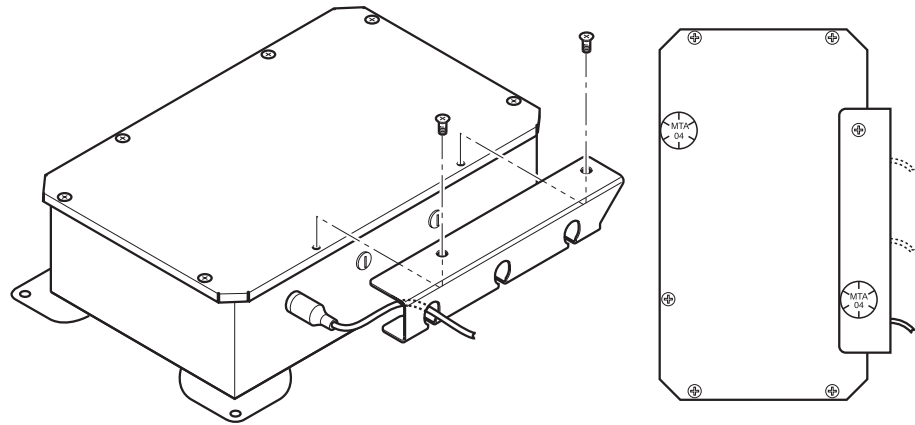

1. Connect weighing platform(s) and terminal(s)/PC(s) in the PSU power supply unit according to the terminal diagram.
2. Put housing cover in place. Ensure proper seating of cover seal when doing so.
3. Secure housing cover with 6 screws. Don't screw in any screws on the COM port side yet.
4. Position verification bracket on the COM port side so that all plugs of the data cables are behind the verification bracket. Guide data cables outward via the respective slots.
5. Secure verification bracket and housing cover to lower housing section with 2 screws.
6. Secure a fastening screw of the verification bracket and another fastening screw of the housing cover with a slide mark.

4.2 Fabricating weighing platform cables

Customer-specific weighing platform cables for intrinsically safe circuits must be fabricated as follows:

	Cable	Dimension A (consuming device)	Dimension B (PSU)	Max. length
ID7sx – PSU	9x2x0.5 mm ²	215 mm	215 mm	80 m
K...x/D...x/System solution Point Ex – PSU	3x2x0.75 mm ²	80 mm	215 mm	100 m
VIPER EX – PSU	4x2x0.5 mm ² + 1 x 0.5 mm ²	215 mm	215 mm	50 m

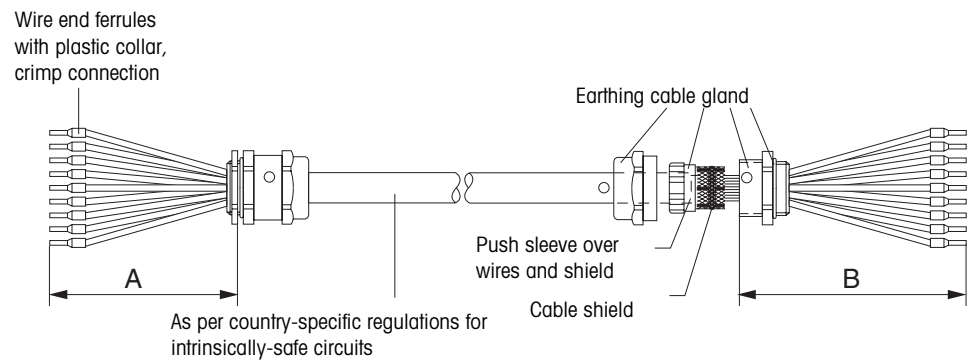

1. Cut cable to length and strip cable ends according to dimension A/B.
2. Shorten shielding on both sides to 10 mm.
3. Strip wire ends.
4. Crimp wire end ferrules onto wire ends with a crimping tool.
5. Push second rear section of earthing cable gland onto cable.
6. Push sleeve over wires and shield. Fold over cable shield.
7. Push on front section of cable gland and screw onto rear section.

4.3 Installing additional scale interface

Up to 3 TBrick-Ex, Point-Ex or Viper-Ex (SW) slotcards can be installed in the PSU if this has not already been done at the factory.

Note

To ensure maximum operating life of the individual slotcards, the respective peripheral device must always be connected.

4.3.1 Configurations with ID7sx weighing terminal

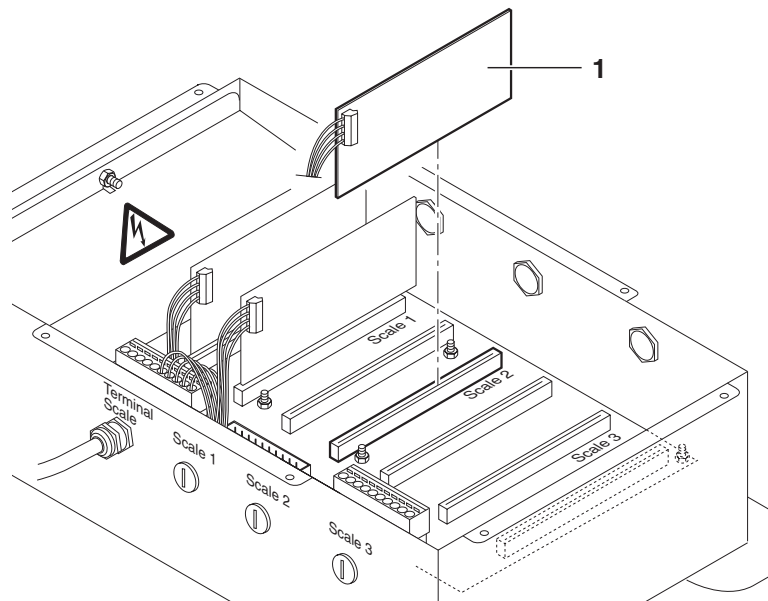

1. Disconnect power plug.
2. Open PSU housing cover.
3. Loosen corresponding 3 wires from the dummy plug on the housing interior and connect to plug S1 of the slotcard according to the terminal diagram.
4. Insert slotcard (1) into slot Scale 2 or Scale 3 of the mainboard.
5. Lay cable in the cable holder on the inside of the housing.
6. Close housing cover. Ensure correct position of seal when doing so.
7. Connect weighing platform cable for intrinsically-safe circuits to the ID7sx weighing terminal in accordance with control drawing 22006478. See also guide for installers of ID7sx ME-22008316.

4.3.2 Configurations without a weighing terminal

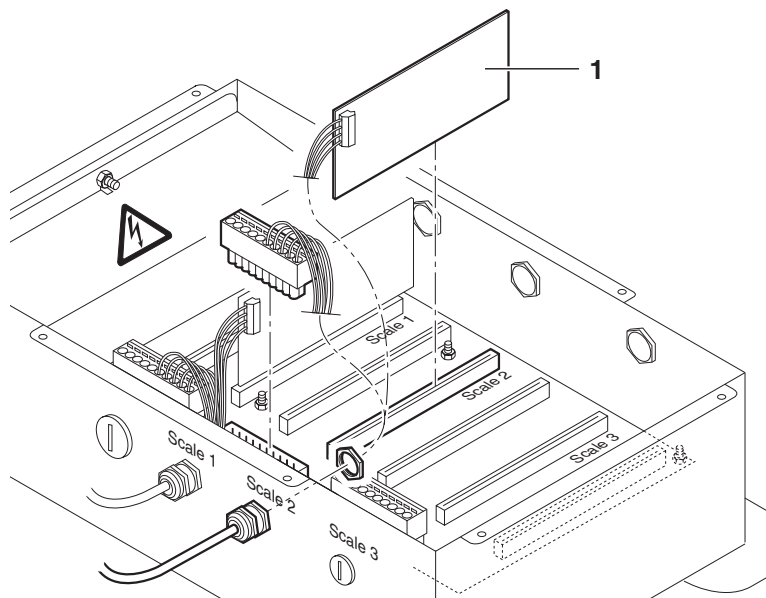

1. Disconnect power plug.
2. Open PSU housing cover.
3. Fit weighing platform cable for intrinsically safe circuits on socket of Scale 2 or Scale 3. Ensure correct position of seals when doing so.
4. Pull plug S2 or S3 off mainboard.
5. Connect 5 wires to plug S2 or S3 in accordance with terminal diagram and insert plug in mainboard again.
6. Connect remaining wires to plug S1 of the slotcard in accordance with terminal diagram.
7. Insert slotcard (1) into slot Scale 2 or Scale 3 of the mainboard.
8. Lay cable in the cable holder on the inside of the housing.
9. Close housing cover. Ensure correct position of seal when doing so.
10. Connect weighing platform cable for intrinsically-safe circuits to the K...x/D...x weighing platform or VIPER EX compact scale in accordance with control drawing 22006477.

4.4 Installing data interface

4.4.1 Required components

PSU and ID7sx weighing terminal

The ID7sx weighing terminal communicates with peripheral devices in the safe area via a CL20mA or RS232 interface.

For this purpose, a **slotcard interface** with the **RS232-PSU or CL20mA-PSU module** is required on **COM1**.

PSU and VIPER EX compact scale(s)

The VIPER EX compact scales communicate with peripheral devices in the safe area via a CL20mA or RS232 interface.

For this purpose, a **slotcard interface** with the **RS232-PSU or CL20mA-PSU module** is required for each **slotcard Viper-Ex (SW)**.

PSU and K...x/D...x weighing platform(s)/ Point Ex system solution

If K...x or D...x weighing platforms are connected directly to the PSU power supply unit, the **modul data conversion** and a **slotcard interface** with the **CL20mA-PSU module** are required for each **slotcard TBrick-Ex** and **Point-Ex** for data transfer to an ID terminal in the safe area.

4.4.2 Preparing RS232-PSU module



EXPLOSION HAZARD

No jumpers may be set on the RS232-PSU module for operation in the PSU power supply unit.

→ Remove any jumpers present on the card before installing an RS232-PSU interface module.

4.4.3 Installing data interface

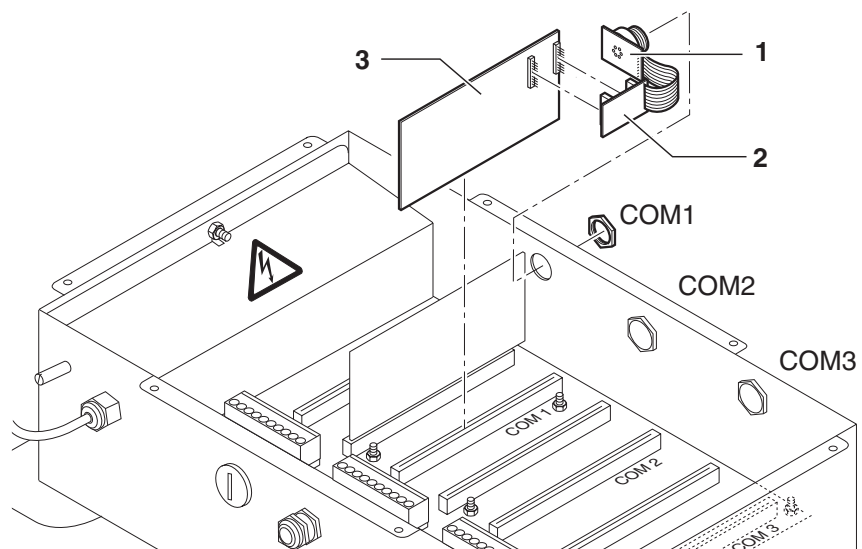



Note

To ensure maximum operating life of the individual slotcards, the respective peripheral device must always be connected as well.

1. Disconnect power plug.
2. Open PSU housing cover and remove blind plug from desired interface connection (COM1, COM2 or COM3).
3. Break socket PCB (1) off interface module RS232-PSU or CL20mA-PSU (2).
4. Unscrew ring nut from socket PCB.
5. Route the socket from the inside of the housing through the hole to the outside.
6. Screw on the ring nut from the outside and tighten it. Ensure proper seating of rubber sealing ring when doing so.
7. Insert slotcard interface (3) on Slot COM1, Slot COM2 or Slot COM3 of PSU mainboard.
8. Insert interface module RS232-PSU (2) or CL20mA-PSU (2) on slotcard interface, plug ST1-ST2.
9. Check/connect RxD and TxD lines in accordance with the respective terminal diagram.
10. Lay cable in the cable holder on the inside of the housing.
11. Close housing cover. Ensure correct position of seal when doing so.

4.5 Setting operating mode on CL20mA-PSU module

The CL20mA-PSU module can be operated with either an active or a passive transmission and reception loop.

Factory setting: Passive transmission and reception loop

1. Disconnect power plug.
2. Open PSU housing cover.
3. Set desired operating mode with DIP switch SA1 on CL20mA-PSU module.

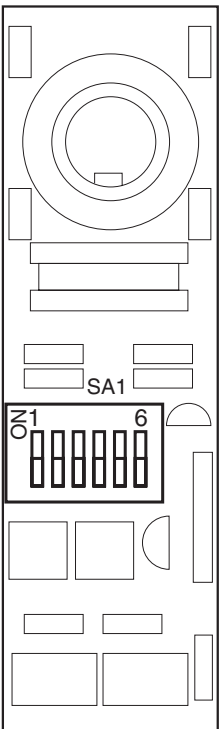

Operating mode	SA1-1	SA1-2	SA1-3	SA1-4	SA1-5	SA1-6
TXD passive, RXD passive (factory setting)	on	on	off	off	off	off
TXD active, RXD active	off	off	on	on	on	on
TXD passive, RXD active	off	on	on	on	off	off
TXD active, RXD passive	on	off	off	off	on	on

4. Close housing cover. Ensure correct position of seal when doing so.

5 Technical data and accessories

5.1 Technical data of PSU

Mains connection	100 – 240 V AC +10 % / –15 %; 50 / 60 Hz; max. 510 mA; approx. 58 VA; $U_m = 250$ V AC	
Mains connection cable	2.4 m; with earthing-pin plug	
Cables (factory configuration)	ID7sx – PSU	10 m
	K...x / D...x – PSU	no cable
	System solution Point Ex – PSU	no cable
	VIPER EX-SW – PSU	10 m
Maximum cable lengths	ID7sx – PSU	80 m
	K...x / D...x – PSU	100 m
	System solution Point Ex – PSU	100 m
	VIPER EX-SW – PSU	50 m
IP protection type	IP65	
Temperature range	–10 °C – +40 °C	
Relative humidity	20 % – 80 %, non-condensing	
Degree of soiling	2	
Installation category	II	
Weight (1 scale can be connected)	PSU/ID...-Ex	12.1 kg including cable
	PSU/Trick-Ex	4.9 kg no cable
	PSU/Point-Ex	4.9 kg no cable
	PSU/Viper-Ex	6.3 kg including cable
Scale slots	3; maximum equipment: 3	
Interface slots	3; maximum equipment: 3	

Dimensional drawing

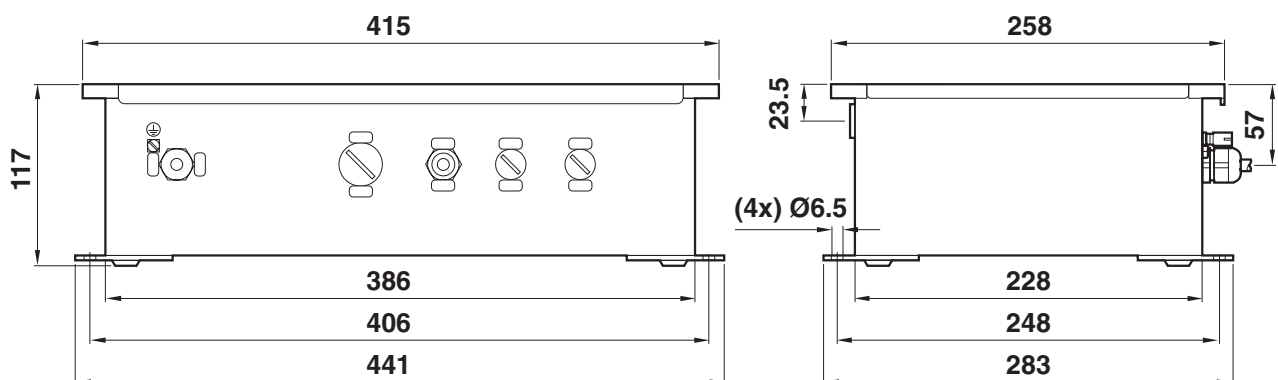

Dim. in mm

5.2 Technical data of RS232-PSU module

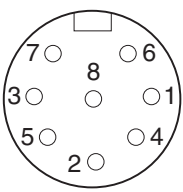
Type of interface	Voltage interface as per EIA RS232C/DIN 66020 (CCITT V.24/V.28)
Control signals DTR, DSR	<ul style="list-style-type: none"> • Signal level 0 (for $R_L > 3\text{ k}\Omega$): $-3\text{ V} - -25\text{ V}$ (low level) • Signal level 1 (for $R_L > 3\text{ k}\Omega$): $+3\text{ V} - +25\text{ V}$ (low level)
Data lines TXD, RXD	<ul style="list-style-type: none"> • Signal level 0 (for $R_L > 3\text{ k}\Omega$): $+3\text{ V} - +25\text{ V}$ (low level) • Signal level 1 (for $R_L > 3\text{ k}\Omega$): $-3\text{ V} - -25\text{ V}$ (low level)
Interface parameters	<p>Operating mode Full duplex</p> <p>Transmission type Bit serial, asynchronous</p> <p>Transmission code ASCII</p> <p>Data bits 7/8</p> <p>Stop bits 1/2</p> <p>Parity Parity even, Parity odd, Parity space, Parity mark, No parity</p> <p>Baud rate 150, 300, 600, 1200, 2400, 4800, 9600, 19200 baud</p>
<p>Socket</p>  <p>External view</p>	<p>8-pin circular plug, socket</p> <p>Pin 1 Earth</p> <p>Pin 2 TXD, scale transmission line</p> <p>Pin 3 RXD, scale reception line</p> <p>Pin 4 DTR, Data Terminal Ready</p> <p>Pin 6 Signal earth</p> <p>Pin 8 DSR, Data Set Ready</p>
Cable	<ul style="list-style-type: none"> • Shielded, twisted pair, max. 15 m • Line resistance $\leq 125\ \Omega/\text{km}$ • Line cross-section $\geq 0.14\text{ mm}^2$ • Line capacity $\leq 130\text{ nF}/\text{km}$

5.3 Technical data of CL20mA-PSU module

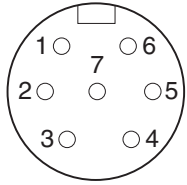
Type of interface	<ul style="list-style-type: none"> • 20 mA current loop, 2 transmission loops • Active or passive operation • Signal level 0: 20 mA • Signal level 1: 0 mA • Electrical isolation only in passive configuration and up to $U = 30 \text{ VAC}$, $\hat{U} = 42 \text{ V}$, $U = 60 \text{ VDC}$ 												
Interface parameters	<table> <tr> <td>Operating mode</td> <td>Full duplex</td> </tr> <tr> <td>Transmission type</td> <td>Bit serial, asynchronous</td> </tr> <tr> <td>Transmission code</td> <td>ASCII</td> </tr> <tr> <td>Data bits</td> <td>7/8</td> </tr> <tr> <td>Parity</td> <td>Even, odd, zero, one, none</td> </tr> <tr> <td>Baud rate</td> <td>150, 300, 600, 1200, 2400, 4800, 9600, 19200</td> </tr> </table>	Operating mode	Full duplex	Transmission type	Bit serial, asynchronous	Transmission code	ASCII	Data bits	7/8	Parity	Even, odd, zero, one, none	Baud rate	150, 300, 600, 1200, 2400, 4800, 9600, 19200
Operating mode	Full duplex												
Transmission type	Bit serial, asynchronous												
Transmission code	ASCII												
Data bits	7/8												
Parity	Even, odd, zero, one, none												
Baud rate	150, 300, 600, 1200, 2400, 4800, 9600, 19200												
Transmission and/or reception loop passive	<p>One external power source supplies the transmission and/or reception loop</p> <table> <tr> <td>I_{\max}</td> <td>30 mA</td> </tr> <tr> <td>U_{\max}</td> <td>27 V</td> </tr> <tr> <td>Voltage range</td> <td>15 V (+10 % / -0 %)</td> </tr> <tr> <td>Current level</td> <td>18 mA – 24 mA (high level)</td> </tr> <tr> <td>Edge steepness</td> <td>2 – 20 mA/μs</td> </tr> </table> <p>To set operating mode, see Section 4.5</p>	I_{\max}	30 mA	U_{\max}	27 V	Voltage range	15 V (+10 % / -0 %)	Current level	18 mA – 24 mA (high level)	Edge steepness	2 – 20 mA/ μs		
I_{\max}	30 mA												
U_{\max}	27 V												
Voltage range	15 V (+10 % / -0 %)												
Current level	18 mA – 24 mA (high level)												
Edge steepness	2 – 20 mA/ μs												
Transmission and/or reception loop active	<p>One internal power source supplies the transmission and/or reception loop</p> <table> <tr> <td>Voltage</td> <td>12 VDC</td> </tr> <tr> <td>Current</td> <td>Adjusted to $\pm 2 \text{ mA}$, for transmission and/or reception loop</td> </tr> </table> <p>To set operating mode, see Section 4.5</p>	Voltage	12 VDC	Current	Adjusted to $\pm 2 \text{ mA}$, for transmission and/or reception loop								
Voltage	12 VDC												
Current	Adjusted to $\pm 2 \text{ mA}$, for transmission and/or reception loop												
<p>Socket</p>  <p>External view</p>	<p>7-pin circular plug, socket</p> <table> <tr> <td>Pin 1</td> <td>RXD+, receiver</td> </tr> <tr> <td>Pin 2</td> <td>RXD-, receiver</td> </tr> <tr> <td>Pin 4</td> <td>TXD+, transmitter</td> </tr> <tr> <td>Pin 5</td> <td>TXD-, transmitter</td> </tr> <tr> <td>Pin 7</td> <td>Protective earth</td> </tr> </table>	Pin 1	RXD+, receiver	Pin 2	RXD-, receiver	Pin 4	TXD+, transmitter	Pin 5	TXD-, transmitter	Pin 7	Protective earth		
Pin 1	RXD+, receiver												
Pin 2	RXD-, receiver												
Pin 4	TXD+, transmitter												
Pin 5	TXD-, transmitter												
Pin 7	Protective earth												
Cable	<ul style="list-style-type: none"> • Shielded, twisted pair • Line resistance $\leq 125 \Omega/\text{km}$ • Line cross-section $\geq 0.14 \text{ mm}^2$ • Line capacity $\leq 130 \text{ nF/km}$ • Max. 1000 m for baud rates up to 4800 baud • Max. 600 m for 9600 baud • Max. 300 m for 19200 baud 												

5.4 Accessories

Serial data interfaces		Order No.
CL20mA-PSU	For installation in the PSU power supply unit	22 006 541
RS232-PSU	For installation in the PSU power supply unit	22 006 542
Accessories for CL20mA-PSU	CL cable, 3 m	00 503 749
	Mating connector, 7-pin	00 503 745
	Second-display cable CL20mA-ID7 – ID1 Plus/ID3s/ID7, 10 m	00 504 511
	Extension cable for second display, 10-pin, 10 m	00 504 134
Accessories for RS232-PSU	RS232 cable/DTE, 3 m	00 503 754
	RS232 cable/DCE, 3 m	00 503 755
	RS232 cable/PC, 3 m	00 504 374
	RS232 cable/9-pin, 3 m	00 504 376
	RS232 cable/Scale, 3 m	22 006 795
	Mating connector, 8-pin	00 503 756

Barcode printer, for the safe area only		Order No.
GA46	Barcode printer in separate desktop housing made of chrome-nickel-steel, protection type IP21 Printing of weighing data and barcodes on 62-mm wide temperature-sensitive paper RS232 interface, cable approx. 2.5 m	00 505 471
GA46/0.4 m	as with GA46, but with 0.4 m cable	00 507 229
GA46-W	as with GA46, but with integrated paper take-up device and transparent PVC protective hood Protection type IP65	00 505 799
GA46-W/0.4 m	as with GA46-W, but with 0.4 m cable	00 507 230

6 Control drawings

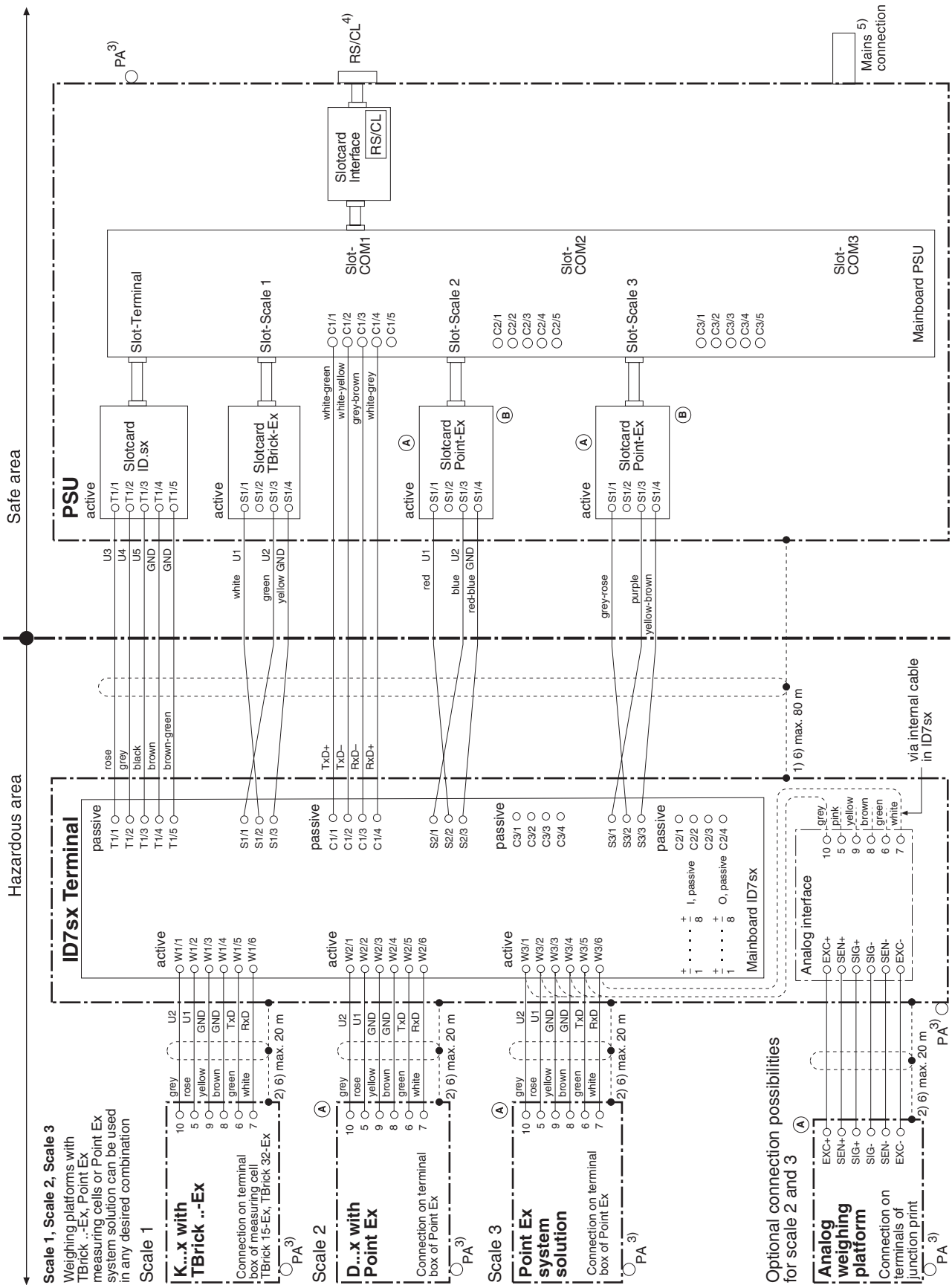

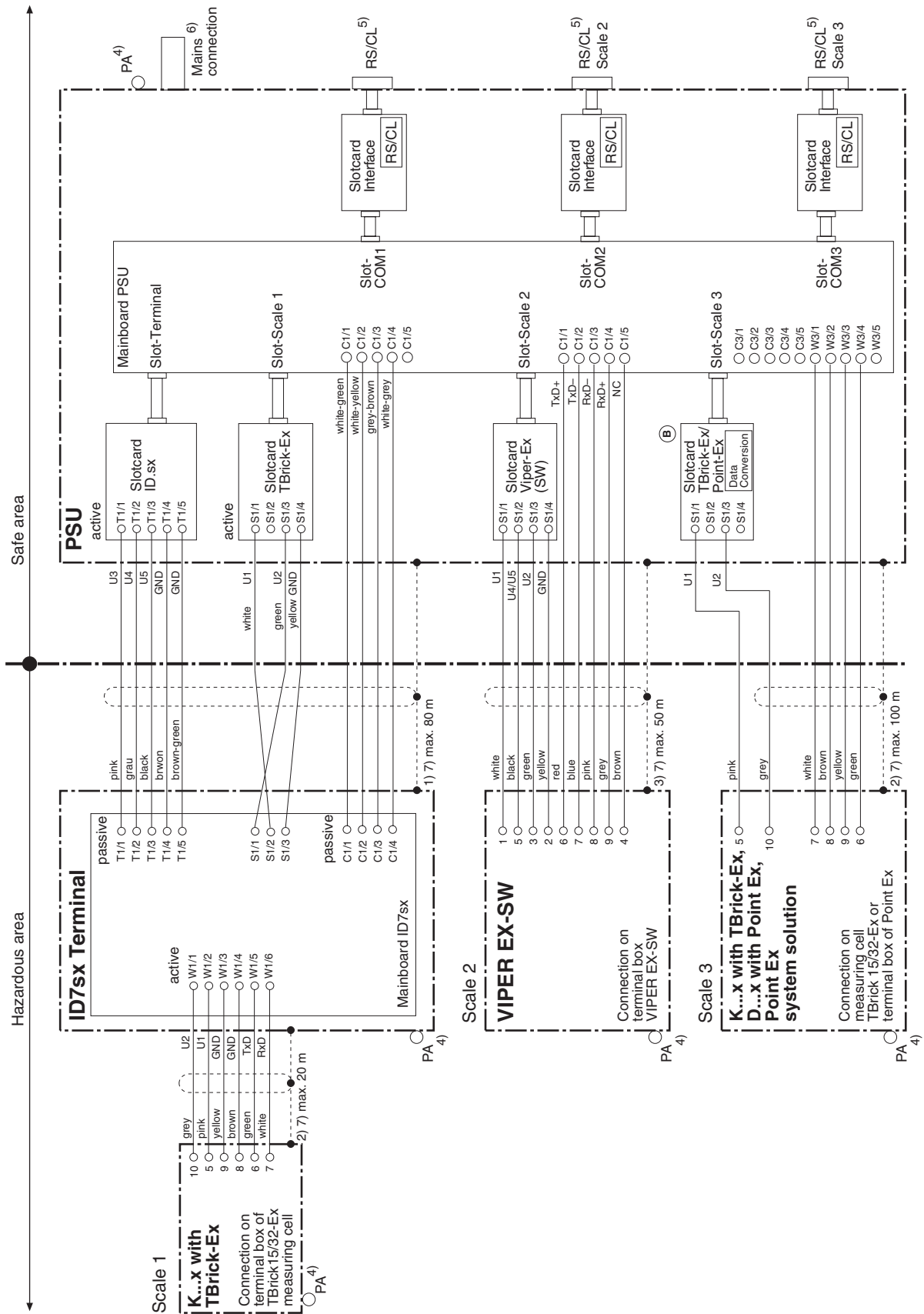

Intrinsically-safe connection values of PSU

ID_sx	U_o/V_{oc}	I_o/I_{sc}	P_o	C_o/C_a	L_o/L_a
U ₃ (T1/1)	8.5 V	151 mA	1.29 W	0.75 µF	0.5 mH
U ₄ (T1/2)	9.1 V	80 mA	0.73 W	0.9 µF	0.5 mH
U ₅ (T1/3)	6.4 V	237 mA	1.52 W	0.9 µF	0.25 mH

TBrick-Ex	U_o/V_{oc}	I_o/I_{sc}	P_o	C_o/C_a	L_o/L_a
U ₁ (S1/1)	8.7 V	92 mA	0.81 W	1 µF	0.3 mH
U ₂ (S1/3)	12.6 V	42 mA	0.53 W	0.4 µF	1 mH

Point-Ex	U_o/V_{oc}	I_o/I_{sc}	P_o	C_o/C_a	L_o/L_a
U ₁ (S1/1)	8.7 V	92 mA	0.81 W	1 µF	0.3 mH
U ₂ (S1/3)	12.6 V	92 mA	1.16 W	0.4 µF	0.5 mH

VIPER EX-SW	U_o/V_{oc}	I_o/I_{sc}	P_o	C_o/C_a	L_o/L_a
U ₁	8.7 V	133 mA	1.15 W	1 µF	0.3 mH
U ₂	12.6 V	42 mA	0.53 W	0.4 µF	1 mH
U ₄	10.5 V	73 mA	0.77 W	1 µF	0.3 mH

Interface	U_o/V_{oc}	I_o/I_{sc}	P_o	C_o/C_a	L_o/L_a
TxD-, TxD+ (C1/3; C1/4)	13.5 V	22 mA	0.3 W	0.15 µF	5 mH
RxD-, RxD+ (C1/1; C1/2)	13.5 V	22 mA	0.3 W	0.15 µF	5 mH

Data conversion	U_o/V_{oc}	I_o/I_{sc}	P_o	C_o/C_a	L_o/L_a
TxD-, TxD+	10.5 V	17 mA	0.175 W	0.15 µF	5 mH
RxD-, RxD+	10.5 V	17 mA	0.175 W	0.15 µF	5 mH

Intrinsically-safe connection values of Point Ex system solution

Analog interface	U_o/V_{oc}	I_o/I_{sc}	P_o	C_o/C_a	L_o/L_a
U _{Ex}	8.0 V	250 mA	1.2 W	0.1 µF	0.3 mH

GENELEC approval

Cable as per EN50039 and EN60079-14 for intrinsically-safe circuits
 - Cable inlet via earthing cable gland
 - Cable as per guide for installers ME-22006472

- 1) Cable 9 x 2 x 0.5 mm² shielded and twisted pair
- 2) Cable 3 x 2 x 0.75 mm² shielded and twisted pair
- 3) Cable 4 x 2 x 0.5 mm² + 1 x 0.5 mm² shielded and twisted pair
- 4) Connection of equipotential bonding (PA) as per country-specific regulations. It must be ensured that the housings of all devices are connected to the same potential via the PA terminals. No circulating current may flow via the shielding of the intrinsically-safe cables
- 5) For connecting devices with a maximum peak voltage of 375 V
- 6) Mains connection of PSU as per country-specific regulations; for mains voltage and frequency, see rating plate
- 7) Lay cabling securely so that it does not move and effectively protect it against damage

FM (FactoryMutual) approval

For installation as per ANSUI/ISA RP 12.06.01, "Installation of intrinsically-safe devices in Class I hazardous areas".
 Cable as per country-specific regulations for intrinsically-safe circuits

- Cable inlet via earthing cable gland
 - Cable as per guide for installers ME-22006472
- 1) Cable 9 x 2 x 0.5 mm² shielded and twisted pair
 - 2) Cable 3 x 2 x 0.75 mm² shielded and twisted pair
 - 3) Cable 4 x 2 x 0.5 mm² + 1 x 0.5 mm² shielded and twisted pair
 - 4) Connection of the equipotential bonding (PA) as per ANS/NFPA 70, Article 504 and ANS/IA RP 12.06.01. It must be ensured that the housings of all devices are connected to the same potential via the PA terminals. No circulating current may flow via the shielding of the intrinsically-safe cables.
 - 5) For connecting devices with a maximum effective value of 250 V
 - 6) Mains connection of PSU as per country-specific regulations; see rating plate for mains voltage and frequency
 - 7) Lay cabling securely so that it does not move and effectively protect it against damage

B	/	07/04	Schultz																	
A	/	11/03	Schultz																	
Ed.	Change	Date	Name	Proc. by	Date		Name		Scale	Designation	Replacement for:									
				Checked	05/03	Schultz	05/03	Schultz												
Mettler-Toledo (Albstadt) GmbH D-72458 Albstadt											Code	22006478	Sheet	2/3						

ID7sx – intrinsically safe output values

Active CL/IDNet-ID7sx	U_o/V_{oc}	I_o/I_{sc}	P_o	C_o/C_a	L_o/L_a
Output TxD (W_A.5 - W_A.3)	7.2 V	21 mA	0.16 W	100 nF	0.1 mH
Output RxD (W_A.6 - W_A.3)	7.2 V	19 mA	0.14 W	100 nF	0.1 mH

RS interface	U_o/V_{oc}	I_o/I_{sc}	P_o	C_o/C_a	L_o/L_a
U6 (R./2 – R./1)	5.45V	220 mA	–	50 μ F	0.25 mH
TxD (R./4 – R./1)	\pm 5.45V	43 mA	–	1 μ F	0.25 mH

RS interface	U_i	J_i	P_i	C_i	L_i
RxD (R./3 – R./1)	\pm 5.45	54 mA	–	–	–

CENELEC approval

Cable as per EN50039 and EN60079-14 for intrinsically-safe circuits
 - Cable inlet via earthing cable gland
 - Cable as per guide for installers ME-22006472
 1) Cable 9 x 2 x 0.5 mm² shielded and twisted pair
 2) Cable 3 x 2 x 0.75 mm² shielded and twisted pair
 3) Cable 4 x 2 x 0.5 mm² + 1 x 0.5 mm² shielded and twisted pair
 4) Connection of equipotential bonding (PA) as per country-specific regulations. It must be ensured that the housings of all devices are connected to the same potential via the PA terminals. No circulating current may flow via the shielding of the intrinsically-safe cables
 5) For connecting devices with a maximum peak voltage of 375 V
 6) Mains connection of PSU as per country-specific regulations; for mains voltage and frequency, see rating plate
 7) Lay cabling securely so that it does not move and effectively protect it against damage

FM (FactoryMutual) approval

For installation as per ANSU/ISA RP 12.06.01, "Installation of intrinsically-safe devices in Class I hazardous areas".
 Cable as per country-specific regulations for intrinsically-safe circuits
 - Cable inlet via earthing cable gland
 - Cable as per guide for installers ME-22006472
 1) Cable 9 x 2 x 0.5 mm² shielded and twisted pair
 2) Cable 3 x 2 x 0.75 mm² shielded and twisted pair
 3) Cable 4 x 2 x 0.5 mm² + 1 x 0.5 mm² shielded and twisted pair
 4) Connection of the equipotential bonding (PA) as per ANS/NFPA 70, Article 504 and ANS/IA RP 12.06.01. It must be ensured that the housings of all devices are connected to the same potential via the PA terminals. No circulating current may flow via the shielding of the intrinsically-safe cables.
 5) For connecting devices with a maximum effective value of 250 V
 6) Mains connection of PSU as per country-specific regulations; see rating plate for mains voltage and frequency
 7) Lay cabling securely so that it does not move and effectively protect it against damage

B	/	07/04	Schultz	Scale		Designation		
A	/	11/03	Schultz	Date	Name	Control drawing PSU-ID7sx		
Ed.	Change	Date	Name	Proc. by	Schultz	Checked	Schultz	
				Checked	Schultz			
Replacement for:				Code				
METTLER TOLEDO				Mettler-Toledo (Albstadt) GmbH D-72458 Albstadt				22006478
							Sheet	
							3/3	

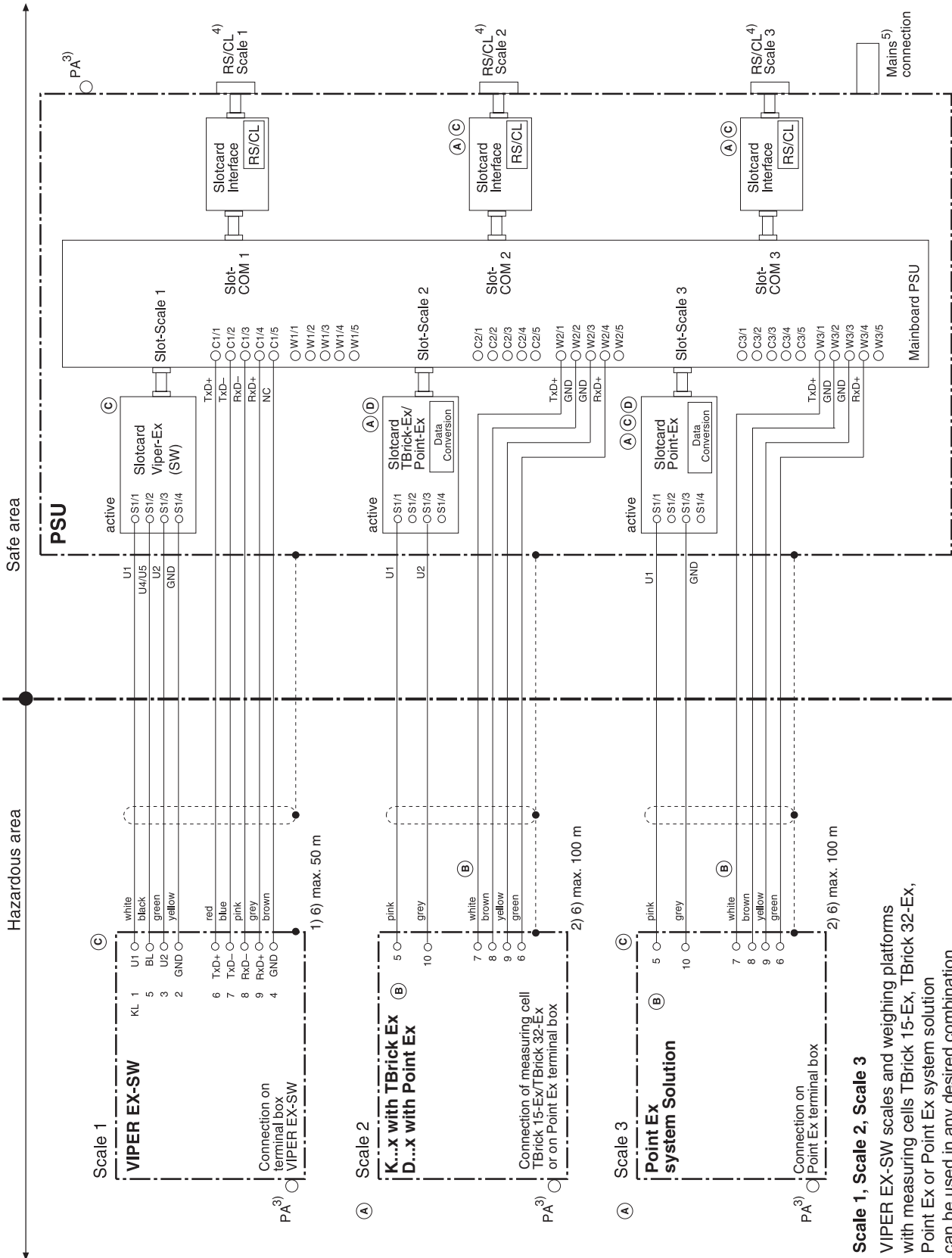

Scale 1, Scale 2, Scale 3

VIPER EX-SW scales and weighing platforms with measuring cells TBrick 15-Ex, TBrick 32-Ex, Point Ex or Point Ex system solution can be used in any desired combination

Intrinsically-safe connection values of PSU

VIPER EX-SW	U_o/V_{oc}	I_o/I_{sc}	P_o	C_o/C_a	L_o/L_a
U ₁	8.7 V	133 mA	1.15 W	1 µF	0.3 mH
U ₂	12.6 V	42 mA	0.53 W	0.4 µF	1 mH
U ₄	10.5 V	73 mA	0.77 W	1 µF	0.3 mH

TBrick-Ex	U_o/V_{oc}	I_o/I_{sc}	P_o	C_o/C_a	L_o/L_a
U ₁	8.7 V	92 mA	0.81 W	1 µF	0.3 mH
U ₂	12.6 V	42 mA	0.53 W	0.4 µF	1 mH

Point-Ex	U_o/V_{oc}	I_o/I_{sc}	P_o	C_o/C_a	L_o/L_a
U ₁ (S1/1)	8.7 V	92 mA	0.81 W	1 µF	0.3 mH
U ₂ (S1/3)	12.6 V	92 mA	1.16 W	0.4 µF	0.5 mH

Interface	U_o/V_{oc}	I_o/I_{sc}	P_o	C_o/C_a	L_o/L_a
TxD-, TxD+	13.5 V	22 mA	0.3 W	0.15 µF	5 mH
RxD-, RxD+	13.5 V	22 mA	0.3 W	0.15 µF	5 mH

Data conversion	U_o/V_{oc}	I_o/I_{sc}	P_o	C_o/C_a	L_o/L_a
TxD-, TxD+	10.5 V	17 mA	0.175 W	0.15 µF	5 mH
RxD-, RxD+	10.5 V	17 mA	0.175 W	0.15 µF	5 mH

CENELEC approval

Cable as per EN50039 and EN60079-14 for intrinsically-safe circuits

- Cable inlet via earthing cable gland
- Cable as per guide for installers ME-22006472

- 1) Cable 4 x 2 x 0.5 mm² + 1 x 0.5 mm² shielded and twisted pair
- 2) Cable 3 x 2 x 0.75 mm² shielded and twisted pair
- 3) Connection of equipotential bonding (PA) as per country-specific regulations. It must be ensured that the housings of all devices are connected to the same potential via the PA terminals. No circulating current may flow via the shielding of the intrinsically-safe cables
- 4) For connecting devices with a maximum peak voltage of 375 V
- 5) Mains connection of PSU as per country-specific regulations; for mains voltage and frequency, see rating plate
- 6) Lay cabling securely so that it does not move and effectively protect it against damage

FM (FactoryMutual) approval

For installation as per ANSU/ISA RP 12.06.01, "Installation of intrinsically-safe devices in Class I hazardous areas"

Cable as per country-specific regulations for intrinsically-safe circuits

- Cable inlet via earthing cable gland
 - Cable as per guide for installers ME-22006472
- 1) Cable 9 x 2 x 0.5 mm² shielded and twisted pair
 - 2) Cable 3 x 2 x 0.75 mm² shielded and twisted pair
 - 3) Connection of the equipotential bonding (PA) as per ANS/NFPA 70, Article 504 and ANS/IA RP 12.06.01. It must be ensured that the housings of all devices are connected to the same potential via the PA terminals. No circulating current may flow via the shielding of the intrinsically-safe cables.
 - 4) For connecting devices with a maximum effective value of 250 V
 - 5) Mains connection of PSU as per country-specific regulations; see rating plate for mains voltage and frequency
 - 6) Lay cabling securely so that it does not move and effectively protect it against damage

D	/	07/04	Schultz
C	/	11/03	Schultz
B		05/03	Schultz
A	/	04/02	Schultz
Ed.	Change	Date	Name
		Proc. by	Name
		Checked	Schultz
Replacement for:			

Scale		Designation	
		PSU control drawing	
Mettler-Toledo		Code	
Mettler-Toledo (Albstadt) GmbH D-72458 Albstadt		22006477	



22006472C

Subject to technical changes © Mettler-Toledo (Albstadt) GmbH 04/09 Printed in Germany 22006472C

Mettler-Toledo (Albstadt) GmbH

D-72458 Albstadt

Tel. ++49-7431-14 0, Fax ++49-7431-14 232

Internet: <http://www.mt.com>