

CS5120 MeasuringArm™

Accurately Dimensioning All Shapes



Measures most objects

not just rectangular boxes. The CS5120 MeasuringArm™ provides the dimensions of the smallest rectangular box that will fit over the object and will measure objects up to 1000 x 600 x 700 mm.



Flexible Installation

to any location. The system can be placed anywhere and measure over most backgrounds. The device is easily adapted or integrated and can be added to an existing goods flow. The system can be used as a sorting station with 3 directional movement of packages.



High Accuracy

with proven PILAR™ Technology. An infrared light measures hundreds of thousands of points looking at the object from the top. A parallel light path is generated that scans and identifies all details of the object. This makes dimensioning flexible, accurate and reliable with all data clearly presented on a display.



Easy to operate

with a user-friendly work-station. Once an object is placed under the device, the unit starts automatically. The system can also be started manually. There are no demands on object orientation and goods can be handled from any direction.



All necessary data

including Product ID, dimensions and weight are captured and used to form a database, creating a unique profile for each object. The data gathered is used in the logistics process from beginning to end.



CS5120 MeasuringArm™ Data Capture Solution

For a very reasonable investment, you can use the CS5120 MeasuringArm™ to accurately measure almost any object. Data gathered by the dimensioner is easily transferred to a warehouse management system and can be used directly to optimise storage locations, order picking, order checking, as well as shipment planning and optimisation.

The CS5120 MeasuringArm™ provides the user with a throughput of 500-700 parcels or objects per hour, and fits well with the needs of small and medium sized goods terminals, package drop off centres, post offices as well as shipping docks and warehouses. The unit provides a cost-efficient way of measuring objects automatically, giving benefits such as revenue increase and cost reduction.

CS5120 MeasuringArm™

Static Package Solution

Features and benefits

- Completely modular design. Hardware and software components can be purchased separately or as a proven weighing, dimensioning and identification workstation.
- Reliable dimensions with proven Parallel Infrared LAser Rangefinder technology (PILAR™)
- Recommended METTLER TOLEDO IND425 CC150 scale for accurate weighing.
- Height-adjustable, ergonomically-friendly stand designed to meet the toughest conditions
- Overhead scanning, goods can be handled from any direction
- 3 different table tops - table top to fit each customer's requirements
- On demand metric and/or imperial units for local requirements
- Control operation by a host computer, automatic start with bar-code read
- CS5120 starts measuring from same position every time (configurable). Same handling operation every time simplifying procedures
- Data is sent as the CS5120 sees end of object. This means shorter average measuring time with higher package throughput
- System can be used as a sorting station with 3 directional movement of packages.
- Option of handsfree barcode scanner or wireless handheld barcode scanner.

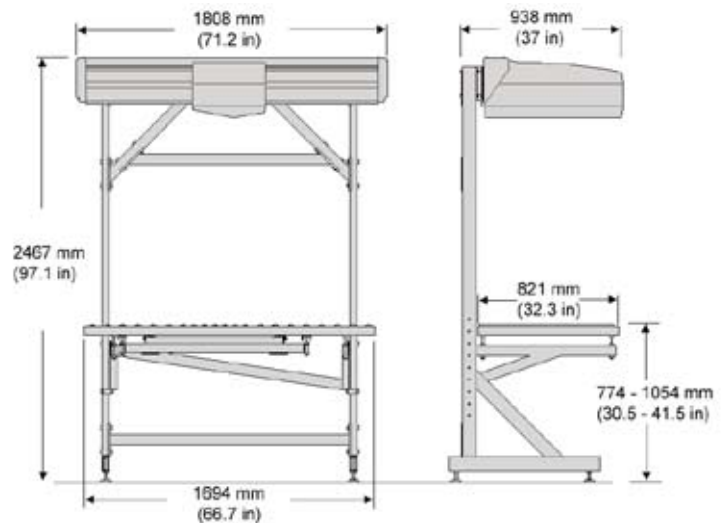

Specifications

Dimensioning accuracy ¹⁾	± 5 mm (± 0.2 in.)
Maximum size (LxWxH)	1000 x 600 x 700 mm (39 x 24 x 28 in.)
Minimum size (LxWxH) ¹⁾	50 x 50 x 25 mm (2 x 2 x 1 in.)
Weight accuracy ²⁾	± 50 g
Maximum weight ²⁾	0.4 kg
Minimum weight ²⁾	60 kg
Throughput	Handsfree solution: 700 parcels/objects per hour. Standard Solution: 500 parcels/objects per hour
Shape	Objects of almost all shapes
Surface characteristics	Most surfaces. Variences are sometimes encountered when surface is transparent/translucent or very glossy
Orientation	Place most suitable surface down. No other restrictions
Background	Measuring area must have a reflective surface. Highest part must define a level plane. Device verifies correct background.
Spacing	Objects are placed under the dimensioner one by one.
Operational temperature	-10° to 40 °C (14° to 104 °F)
Power	230V 50Hz, or 115V 60Hz
Laser type	Class 1, unconditionally safe
Interface	Standard RS232, and binary switches for extra starting capabilities

¹⁾ If the instrument is used in Legal for Trade applications, this specification may vary. The dimensioner has been approved according to local recommendations.
²⁾ May vary with use of other METTLER TOLEDO compatible scales.

Main components

Dimensioner	CS5120 (115V/230V) with CS2300 display
Scale	IND425 CC150 Scale. Other types available.
Bar code reader	Standard solution: Handheld Datalogic Gryphon
	Handsfree solution: Overhead Metrologic IS8500
Accessories	Roller conveyor table, ball transfer table, table, wheels, dimension stand
Application software	Windows based operation, automatic data registration, PC data communication



Quality certificate ISO9001
 National Approvals
 Compliant to health and safety regulations
 Internet: <http://www.mt.com>
 Worldwide service

Subject to technical changes
 © 06/2007 Mettler-Toledo Cargoscan AS
 Printed in Norway 792039
 CSN MarCom Oslo

www.mt.com/cargoscan

Visit for more information