

Installation information

METTLER TOLEDO MultiRange
Floor/Pit scales
DN-Line
SPIDER-Line

METTLER TOLEDO

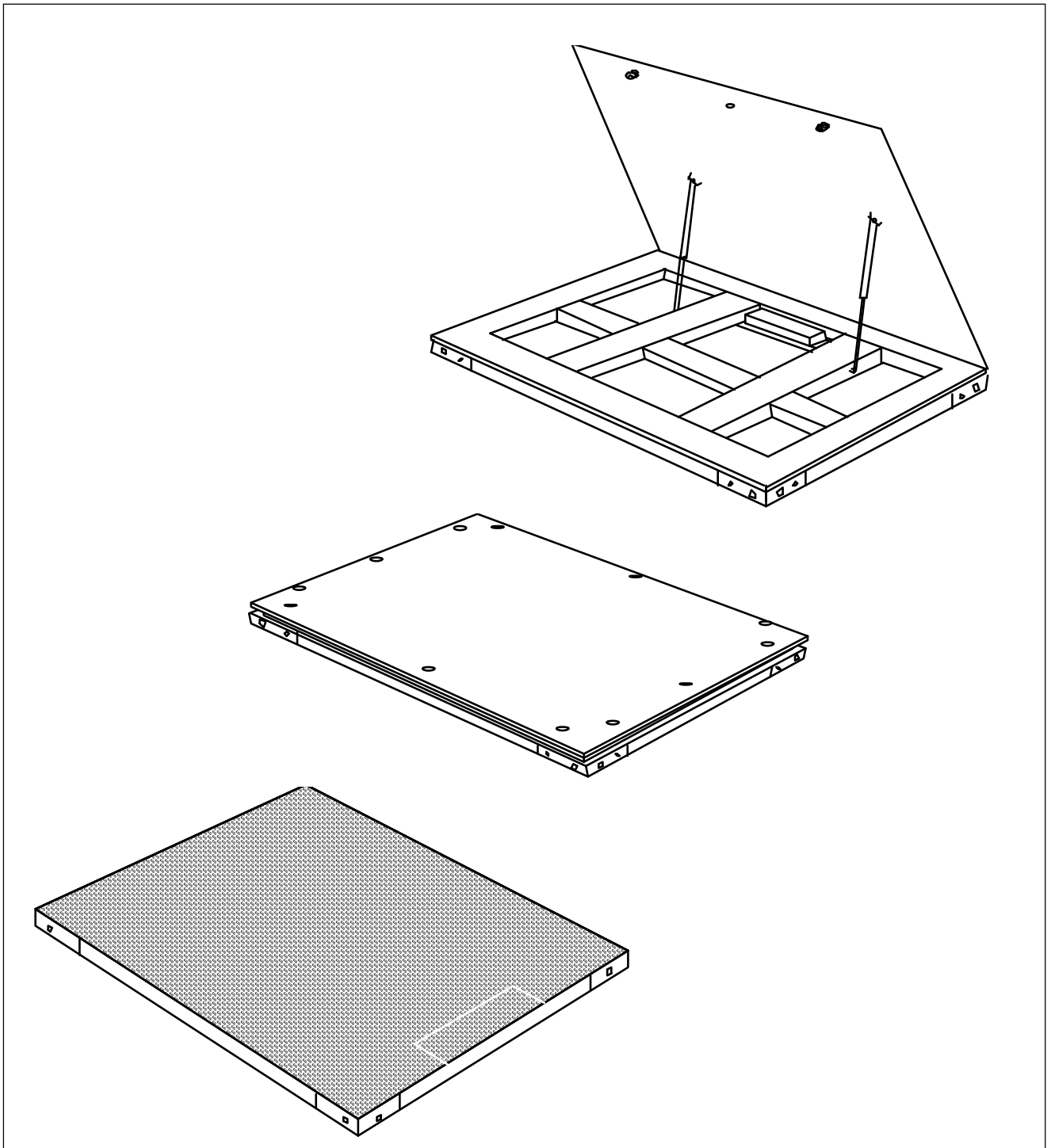

Contents	Page
1. Installation	3
1.1 Preparatory work	3
1.2 Equipotential bonding	3
1.3 Floor installation	4
1.3.1 Connection of SPIDER weighing platforms to SPIDER terminals	5
1.3.2 Terminal connection... ..	5
1.4 Pit installation	6
2. Scale configurations	7
2.1 Configurations DN- / SPIDER weighing platforms (IDNet)	7
2.2 Configurations SPIDER weighing platforms with SPIDER SW/BC/FC/SC terminals	7
3. Planning of attachments	8
3.1 General information	8
3.2 Fastening possibilities	9,10,11
3.3 Fastening dimensions pit frame	12
4. Dimensions	12

1. Installation

1.1 Preparatory work

SPIDER line

- Never operate in hazardous areas!

DN line

- The explosion-protected weighing platform is approved for operation in hazardous areas. (Technical data see operating instruction)

There is an increased danger of injuries and damage when using the weighing platform in hazardous areas!

Exercise particular care when using in such areas. The rules for behavior are based on the concept of " Safe Distribution" established by METTLER TOLEDO.

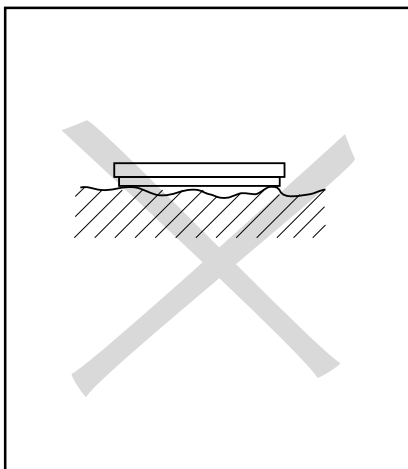

Selection of the location

- The foundation at the installation site must be capable of safely supporting the weight of the scale at the support points when it carries the maximum load. At the same time, it should be so stable that no vibrations occur during weighing operations. These requirements also apply if the weighing platform is integrated in conveying systems and the like.
- Ensure the vibrations due to machines near the installation site are kept a minimum.

Ambient conditions for the SPIDER line

- Use weighing platform only in a dry environment.

Ambient conditions for the DN line

- Weighing platform can be used in a dry or wet environment.

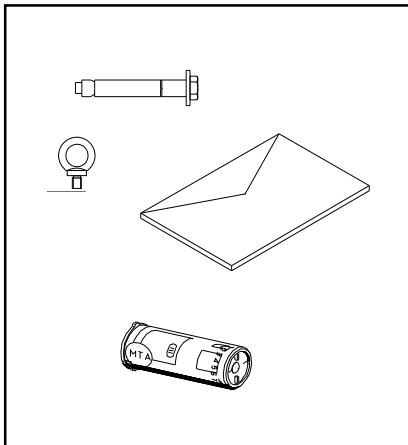

Unpacking the accessories

Please ensure that the accessories supplied with the weighing platform are completely removed from the load frame.

SPIDER line

- 1 set eye bolts
- 1 set dowels
- 1 operating instruction
- 1 set plates

SPIDER...IDNet line

- additional
- 1 identcard

DN line

- 1 set dowels
- 1 set plates
- 1 identcard
- 1 operating instruction

DN...sk line

- additional
- 1 set eye bolts

1.2. Equipotential bonding

The equipotential bonding must be installed by a professional electrician when using the weighing platform in Zones 1/2 and 21/22. METTLER TOLEDO Service only has a monitoring consulting here.

- => Connect equipotential bonding (PA) of all devices (weighing platform and service terminal) in accordance with the country-specific regulations and standards. In the process, make sure that all device housings are connected to the same potential via the PA terminals.

1.3 Floor installation

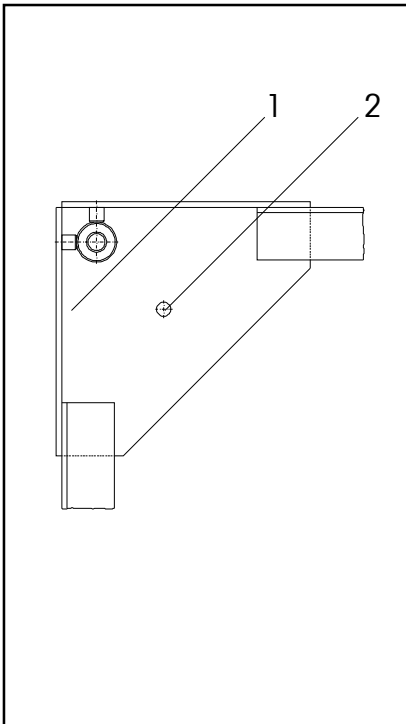

Fastening DN line

- Lift load plate and load frame from base frame.

DN line with hinged load plate

- Open the two rapid lockings with special key.
- Open up the load plate (special key serves as lift-off device).
- Lift the load frame from the pit frame with the help of ring bolts.

SPIDER line

- Lift load frame from base frame using the two eye bolts.
- Place base frame (1) at location. The foundation must be plane. Minor differences in height should be compensated by adjustment plates.
- Mark drill positions (2). Drill out dowel holes and vacuum off debris.
- Fasten base frame to floor with four heavy-duty dowels.
- Route connection cable to terminal through the base frame at the place provided.
- Place load frame vertically on base frame.

Attention

Ensure measuring cell cable is not pinched !

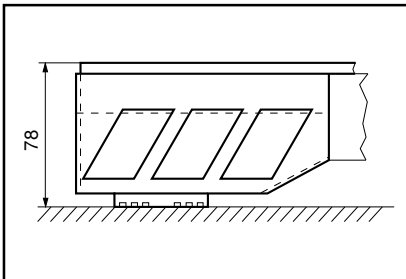

Floor installation without ramp

- For safety reasons, guards painted in signal colors can be mounted at all four corners of the weighing platform.

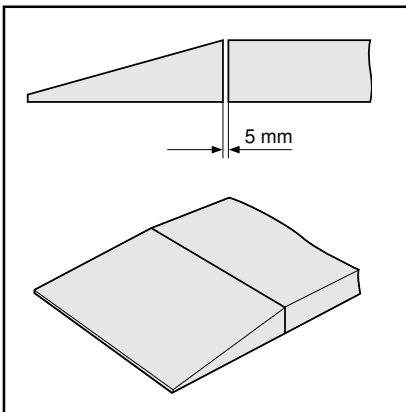

Floor installation with approach ramps

- Place approach ramp next to the weighing platform and align. Distance upper edge to load plate approx. 5mm.
- Raise the load frame and screw bolts for ramp fixation in the holes provided.
- Insert ramp in the slots of the bolts.

1.3.1 Connection of SPIDER weighing platforms to SPIDER terminals

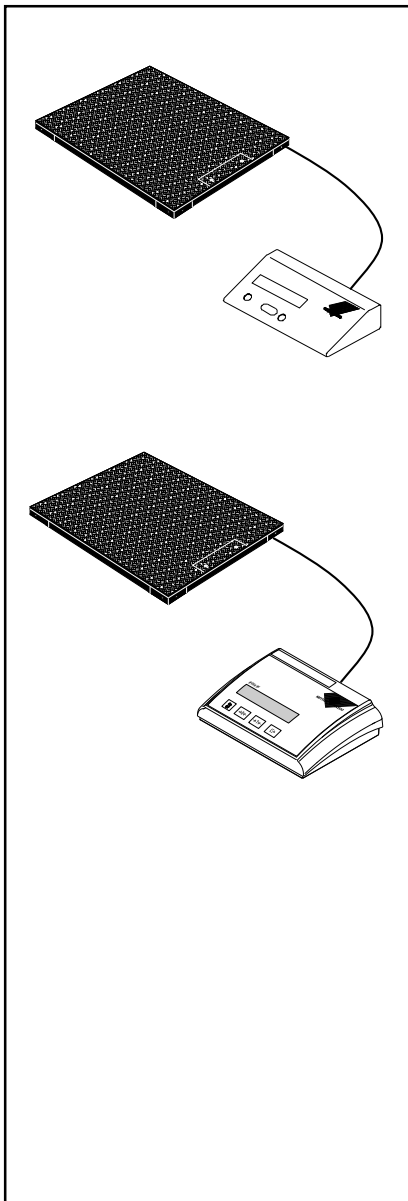

Connection of a SPIDER1/2/3 terminal

- Remove the 3 screws at the left cover of the housing and pull out the complete printed circuit board with the cover plate.
- Lead prepared cable through the housing hole. Screw nut to heavy gauge screw fitting.
- To connect the cable use the connection diagram below.
- Close the housing and fix it with 3 screws.
- For verifacated scales you have to glue a countersunk screw with the safety stamp

Connection of a SPIDER SW/BC/FC/SC terminal

- Release the 6 screws at the rear cover and remove cover.
- Lead the ready-made cable through the bore hole in the housing. Screw the nut on the PG-thread.
- Unplug the green plug and connect the cable according to the colours indicated below.
- Plug in the green plug.
- Put on the cover and fix it with the 6 screws.

Attention

The analogue cable must not be squeezed !

- For verifacated scales you have to glue the countersunk screw with the safety stamp.

The cores of the connection cable carry the following signals:

Terminal	Color	Assignment
EXC+ [IN+]	grey	voltage +
SEN+	yellow	control line +
SIG+ [OUT+]	white	signal +
SIG- [OUT-]	brown	signal -
SEN-	green	control line -
EXC- [IN-]	blue	voltage -

1.2.2 Terminal connection

- Route connection cable to terminal.

Attention

Route connection cable to terminal so that it is protected against possible damage.

- Attach terminal.
Please consult the description of the terminal for the steps involved in attaching the terminal.

1.4 Pit installation

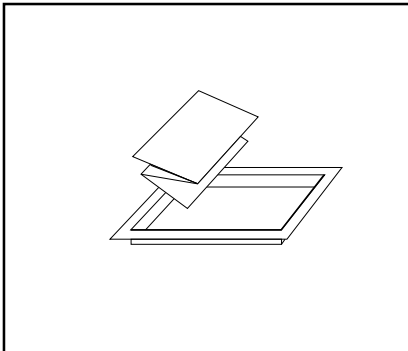

Preparing the pit

The pit installation kit includes the fastening material and a detailed set of pit installation instructions. Proper preparation of the pit following these instructions is assumed here.

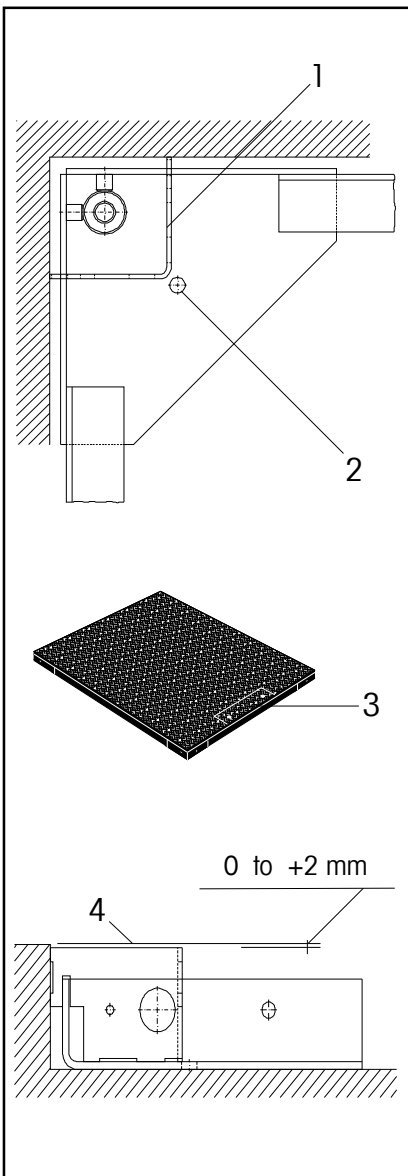

Installing the weighing platform

Some of the work steps involved in installation in the pit are the same as those in floor installation.

- Measure pit depth at the corners (minimum depth for DN line is 88 mm) (minimum depth for N line / SPIDER line is 80 mm).
- Place the base frame as a drill template in the pit and align all sides using the positioning gauge (1).
- Mark drill positions (2). Drill out dowel holes and vacuum off debris.
- Align base frame horizontally. If necessary, place adjustment plates under the corners of the base frame. The distance between the top edge of the positioning gauge and floor should not be less than that shown opposite.(4)
- Fasten base frame with four heavy-duty dowels to pit bottom.

SPIDER line

- Unscrew cover (3) of the load frame.
- Install load frame vertically. Pull the connection cable to the terminal through the hole in the load frame into the reserve conduit or the cable conduit. See pit installation instructions for details regarding routing the reserve conduit to the terminal.

Final inspection:

There should be a uniform distance (approx. 10 mm) on all sides between the load plate and the pit frame.

2. Scale configurations

2.1 Configurations DN- / SPIDER weighing platforms (IDNet)

The scale is configured in the factory as follows:

- verifiable
- SingleRange, 3000 e resolution

The identcard is prepared in the factory with the appropriate measurement data plate.

Type	Maximum load	Readability	
		SingleRange SR verifiable	configurable MultiRange MR verifiable *
DN.../ SPIDER...600	600 kg	0,2 kg	0,1 / 0,2 kg
DN.../ SPIDER...1500	1500 kg	0,5 kg	0,2 / 0,5 kg
DN.../ SPIDER...3000	3000 kg	1,0 kg	0,5 / 1,0 kg

* IDNET version

The scale types listed above are supplied with an A/D-converter Point as standard. Additional versions can thus be configured in the service mode (free mode) description service manual A/D-converter Point 22004256.

Note

If the configuration is changed, the new measurement data plate must be affixed to the identcard.

2.2 Configurations SPIDER weighing platforms with SPIDER SW/BC/FC/SC-terminals

The scale combination SPIDER weighing platform / SPIDER terminal is configured in the factory as follows:

- verifiable
- SingleRange, 3000 e resolution

Type	Maximum load	Readability	
		SingleRange SR verifiable	configurable MultiRange MR verifiable
SPI...600	600 kg	0,2 kg	---
SPI...1500	1500 kg	0,5 kg	---
SPI...3000	3000 kg	1,0 kg	0,5 / 1,0 kg

3. Planning of attachments

3.1 General information



The weighing platform may be fixed only at the corners of the base frame.

Moving or rotating parts on the weighing platform must be so designed that they do not influence the weighing result. Rotating parts must be balanced.

The load frame must be free on all sides to ensure that accumulated dirt or any parts which drop down do not form a bridge between it and the base frame.

Cables or tubing between the weighing platform and other machine parts must be routed so that they do not exert any force on the weighing platform.

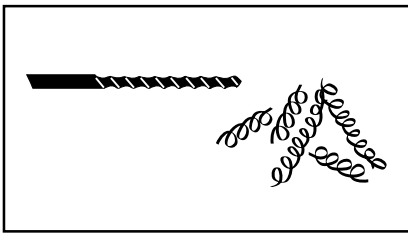

In the mounting of attachments, ensure that no metal filings or turnings fall into the gap between the strain gauge weighing cell and the load frame. Clean gap on completion of mounting work.

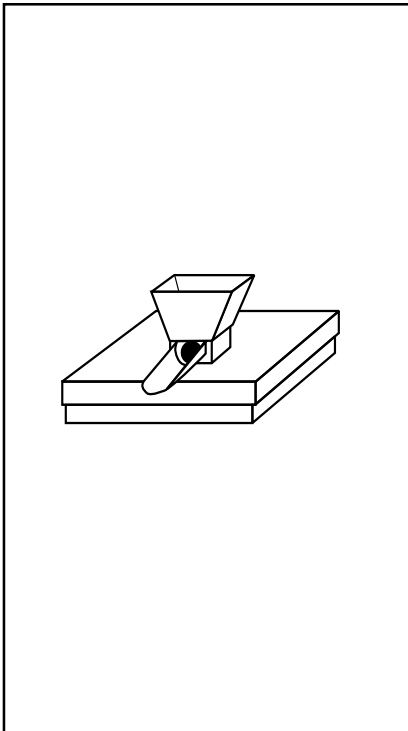

Preload range

The weight of the structural parts which are permanently mounted on the weighing platform is called the preload. If the preload exceeds the preload range, the weighing platform must be compensated electrically, so that the complete weighing range becomes available.

Type	Max. load	Max. preload *
DN...600	600 kg	1200kg
DN...1500	1500 kg	2300kg
DN...3000	3000 kg	800kg

Type	Max. load	Max. preload *
SPI...600	600 kg	1400kg
SPI...1500	1500 kg	2700kg
SPI...3000	3000 kg	1200kg

* **Attention:**

The preload range and the zero setting range must be within the maximum preload.

3.2 Fastening possibilities

Fastening possibilities with SPI-DS...

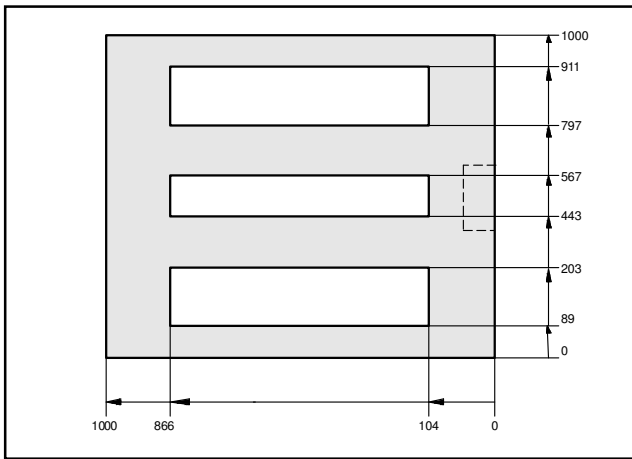

Fastening possibilities with SPI-D...

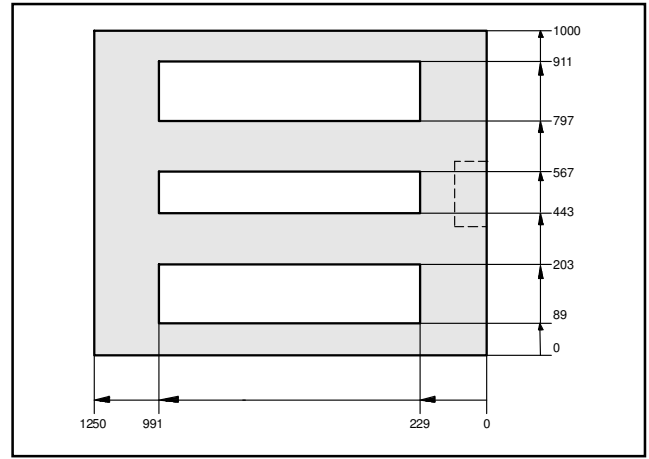

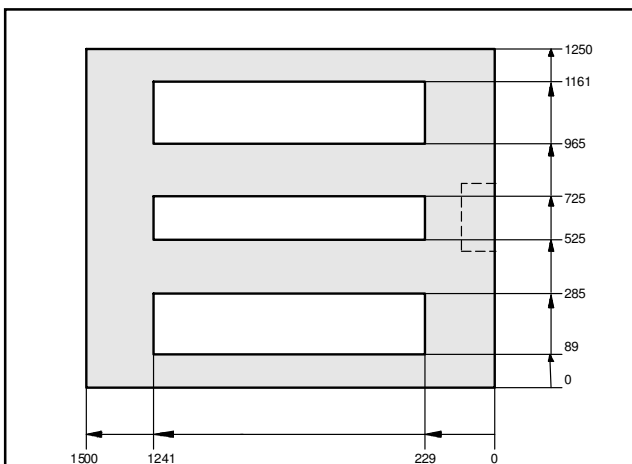

Fastening possibilities with SPI-E...

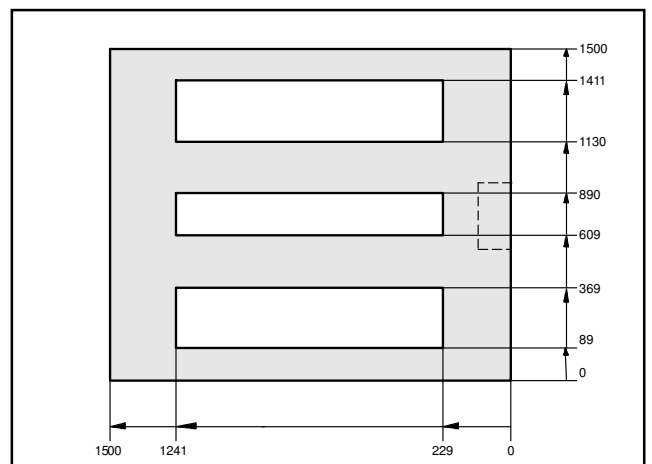

Fastening possibilities with SPI-ES...



-  breakthrough, fastening possibility
-  no breakthrough, fastening possibility

Fastening possibilities with DND...g

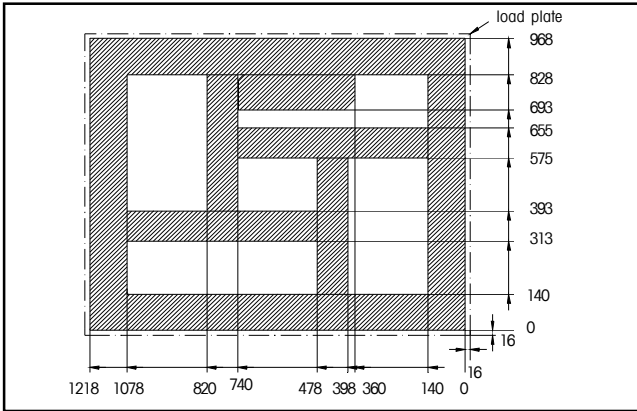

Fastening possibilities with DND...s

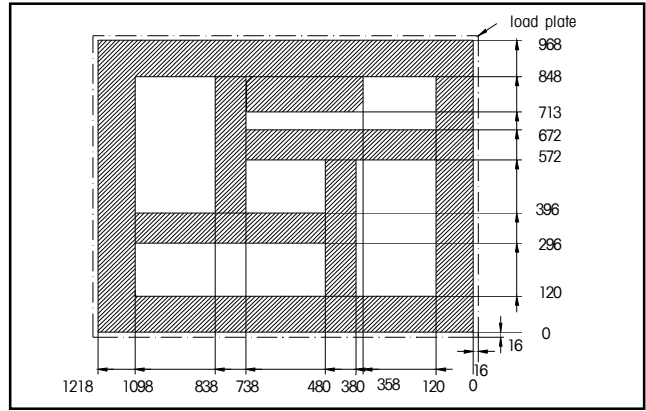

Fastening possibilities with DNE...g

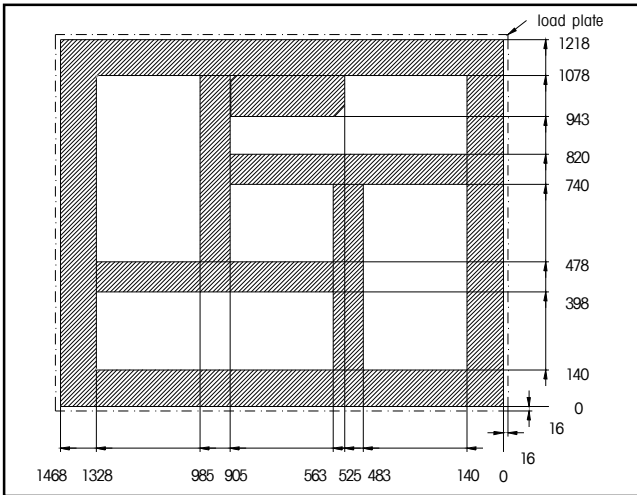

Fastening possibilities with DNE...s

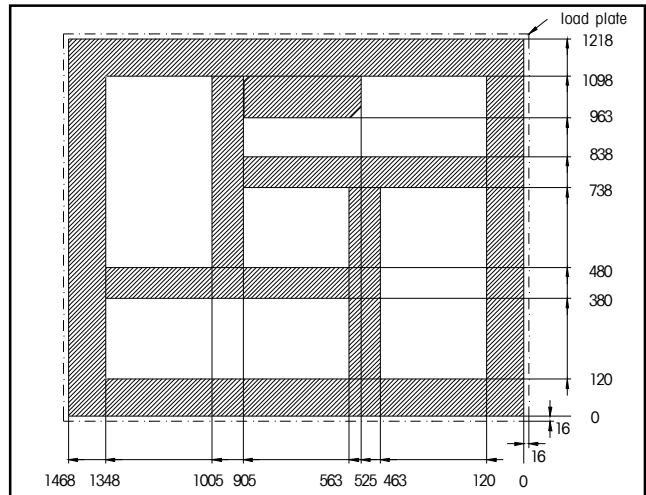

Fastening possibilities with DNES...g

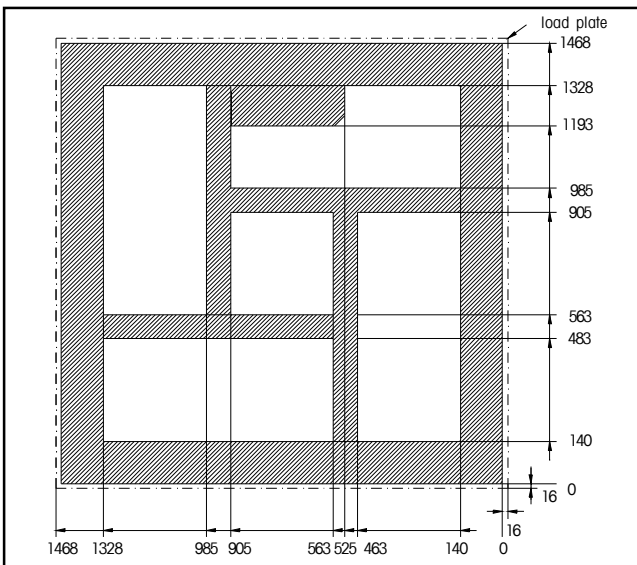

Fastening possibilities with DNES...s

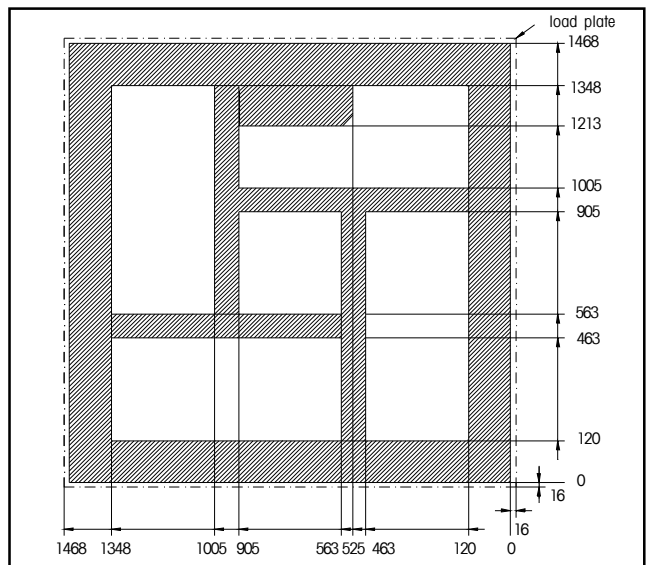

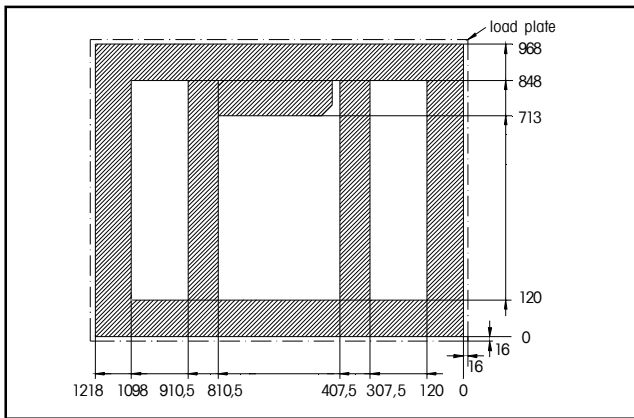

Fastening possibilities with DND...sk

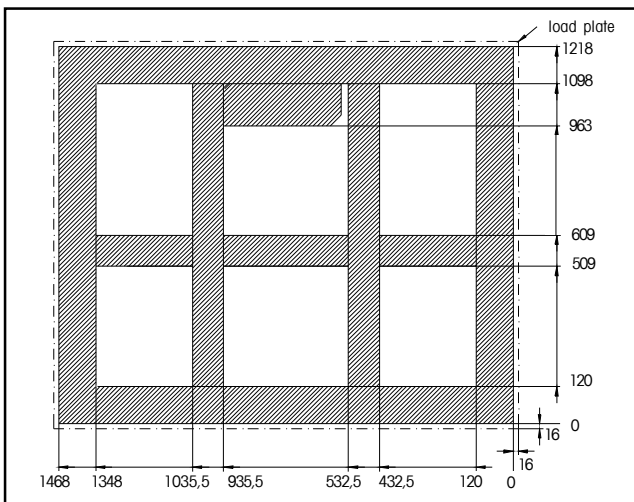

Fastening possibilities with DNE...sk



-  breakthrough, fastening possibility
-  no breakthrough, fastening possibility

Fastening possibilities with DNES...sk

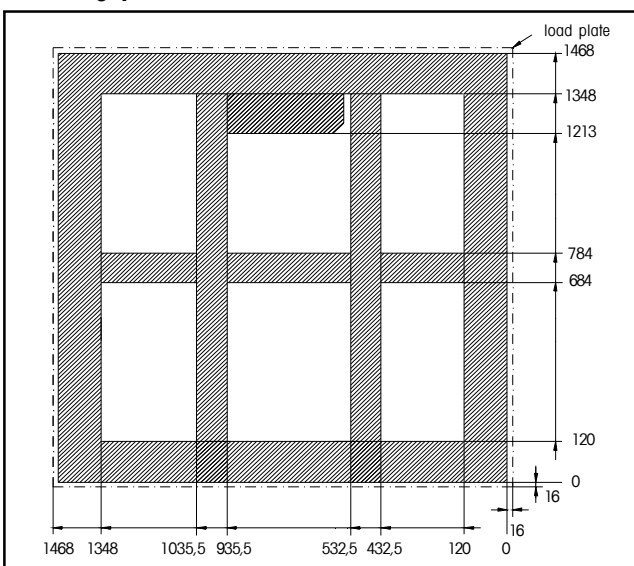

3.3 Fastening dimensions pit frame

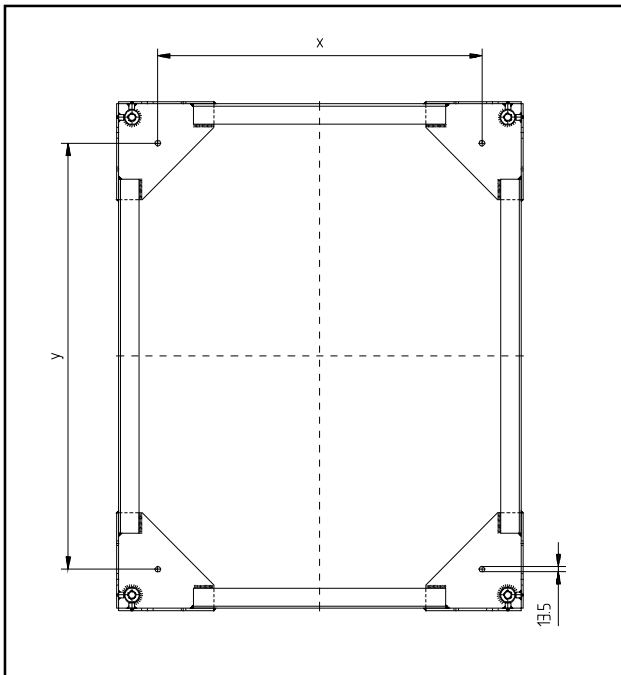

SPIDER line / DN line

Dimensions	SPI-DS...
X	797 mm
Y	797 mm

Dimensions	SPI-D... DND...	SPI-E... DNE...	SPI-ES... DNES...
X	797 mm	1047 mm	1297 mm
Y	1047 mm	1297 mm	1297 mm

**Free size dimensions:
SPIDER...F line / DN...F line**

X	length - 203 mm
Y	width - 203 mm

4. Dimensions

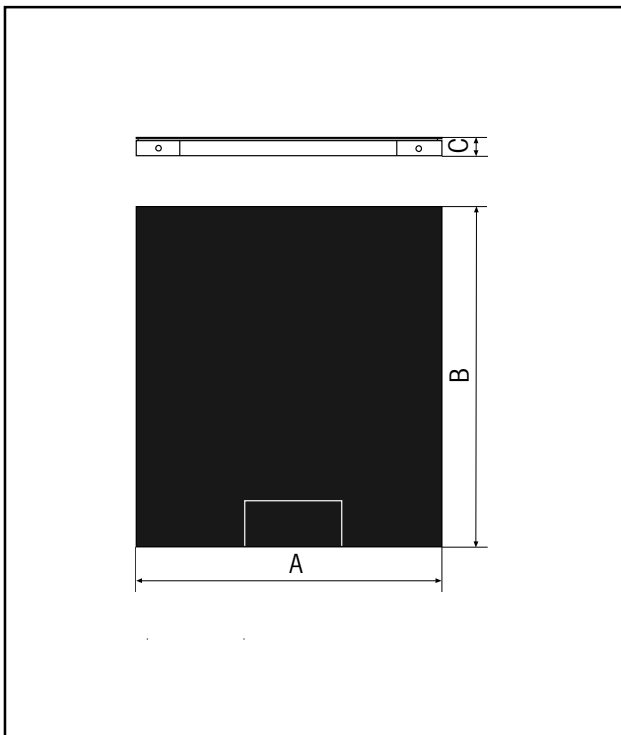

SPIDER line

	SPI-DS...
A	1000 mm
B	1000 mm
C	78 mm

	SPI-D...	SPI-E...	SPI-ES...
A	1000 mm	1250 mm	1500 mm
B	1250 mm	1500 mm	1500 mm
C	78 mm	78 mm	78 mm

DN line

	DND...	DNE...	DNES...
A	1000 mm	1250 mm	1500 mm
B	1250 mm	1500 mm	1500 mm
C	85 mm	85 mm	85 mm



00705807

Subject of technical changes © Mettler-Toledo (Albstadt) GmbH 03/04 Printed in Germany 00705807J

Mettler-Toledo (Albstadt) GmbH

D-72458 Albstadt

Tel. ++49-7431-14 0, Fax ++49-7431-14 232

Internet: <http://www.mt.com>