

# Comparator Balances

AX64004, AX32004, AX16004



**METTLER TOLEDO**



# Overview of your Comparator Balance

## Balance with weight handler



- 1 Turntable with 4 weight positions
- 2 Draft shield (glass cylinder)
- 3 Dial weights, electronically controlled
- 4 On/off switch

# Overview of the Controller

## Balance controller

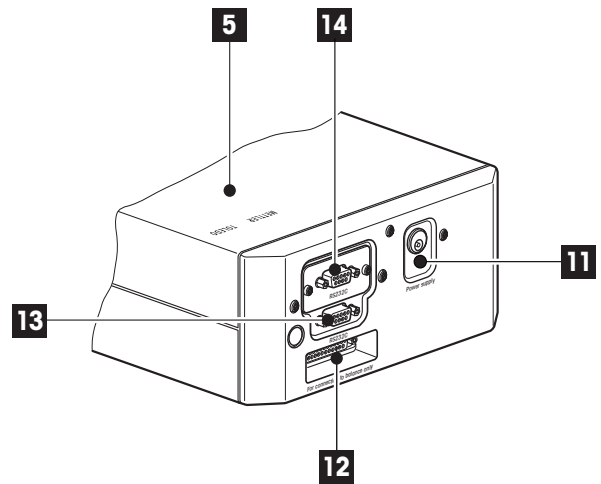
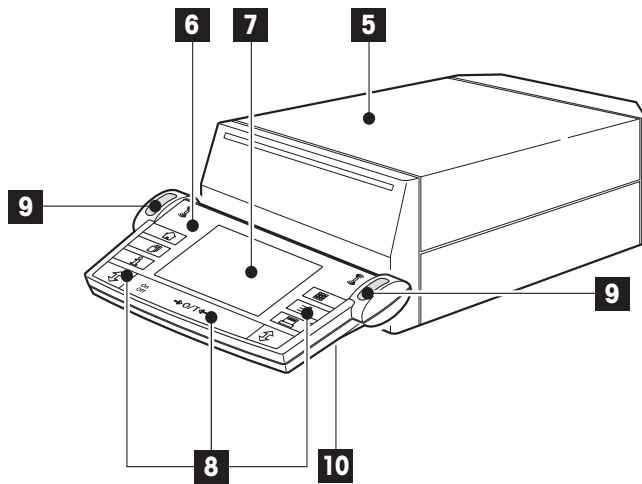

## Process controller

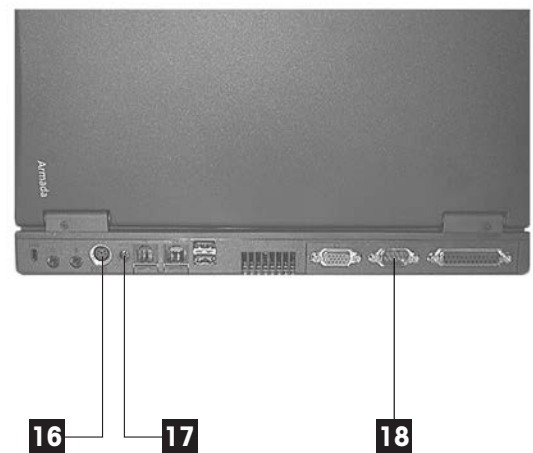

- 5 Control unit
- 6 Terminal (for details see chapter 4)
- 7 Display
- 8 Operating keys
- 9 SmartSens sensors (without function)
- 10 Cover (cable compartment on underside of terminal)
- 11 Socket for AC adapter
- 12 Connecting socket for weighing cell

- 13 Connecting socket for process controller
- 14 Connecting socket for handler controller
- 15 Process controller with "AX-control" software
- 16 Connecting socket for mouse
- 17 Socket for AC adapter
- 18 Connecting socket for balance controller

# Contents

<b>1</b>	<b>Your AX Comparator Balance.....</b>	<b>6</b>
1.1	Introduction.....	6
1.2	Conventions and Symbols Used in These Operating Instructions.....	6
1.3	When do you Work with Which Controller?.....	6
<b>2</b>	<b>Safety Information .....</b>	<b>7</b>
2.1	Definition of Signal Warnings and Symbols.....	7
2.2	Product Specific Safety Notes .....	7
<b>3</b>	<b>Setting up the AX Comparator Balance .....</b>	<b>9</b>
3.1	Delivered Items.....	9
3.2	Items not Included in Standard Delivery.....	9
3.3	Connection Diagram .....	10
3.4	Selecting a Location.....	11
3.5	Location Change .....	12
3.6	Power Supply.....	12
3.7	Adjusting the Reading Angle and Positioning the Terminal .....	13
<b>4</b>	<b>Starting up the Weighing System.....</b>	<b>15</b>
4.1	Switching the Handler on and off from the Weighing Terminal .....	15
<b>5</b>	<b>Operating the Terminal and Firmware .....</b>	<b>16</b>
5.1	Overview of the Terminal.....	16
5.2	The Display.....	17
5.3	Balance Control Firmware for the Comparator Balance .....	18
<b>6</b>	<b>System Settings .....</b>	<b>20</b>
6.1	Calling up the System Settings .....	20
6.2	Overview of the System Settings.....	20
6.3	Settings for Adjustment and Test .....	21
6.3.1	Displaying the Adjustment History ("History").....	21
6.3.2	Defining Adjustment and Test Reports.....	22
6.3.3	Defining an External Adjustment Weight "Adjustweight" .....	23
6.3.4	Defining an External Test Weight "Testweight".....	23
6.3.5	Entering the Weight Certificate Designation "Certificate No.".....	23
6.3.6	Defining the Weight Identification "Weight ID".....	23
6.4	Specifying the Weighing Parameters .....	24
6.5	Selecting Peripheral Devices "Peripherals" .....	25
6.6	Terminal Settings "Terminal" .....	27
6.7	Resetting to the Factory Settings "Factory".....	28
6.8	Date and Time "Date/Time" .....	29
6.9	Energy-saving Function and Battery Change Date "Energy" .....	30
6.10	Balance Information "Balance".....	31

<b>7</b>	<b>The "AACOM" Application .....</b>	<b>32</b>
7.1	Selecting the Application .....	32
7.2	Settings for the "AACOM" Application .....	32
7.2.1	Overview .....	32
7.2.2	Select "Function Keys" .....	34
7.2.3	"SmartTrac" and Stopwatch .....	35
7.2.4	Select Information Field "Info Field" .....	35
7.2.5	AACOM Information .....	36
7.2.6	Selecting Weighing Unit "Display Unit" .....	36
7.2.7	Define Report "Proocol" .....	37
<b>8</b>	<b>Working with the "AACOM" Application .....</b>	<b>38</b>
8.1	Preparing for Centering the Weights .....	38
8.1.1	Load the Turntable .....	38
8.1.2	Centering Principle with Built-in Levelmatic .....	38
8.2	Centering the Weight with the Balance Controller .....	39
8.2.1	Enter the Nominal Weight .....	39
8.2.2	Centering .....	39
8.3	Adjusting the Comparator Balance and Checking the Adjustment .....	40
8.3.1	Adjustment with Internal Weight .....	40
8.3.2	Adjustment with External Weight .....	41
8.3.3	Checking the Adjustment with the Internal Weight .....	42
8.3.4	Checking the Adjustment with the External Weight .....	43
<b>9</b>	<b>Further Important Information .....</b>	<b>44</b>
9.1	Error Messages Occurring During Normal Operation .....	44
9.2	Further Error Messages .....	44
9.3	Cleaning .....	45
9.4	Disposal .....	45
<b>10</b>	<b>Technical Data and Accessories .....</b>	<b>46</b>
10.1	General Data .....	46
10.1.1	Explanatory Notes for the METTLER TOLEDO AC Adapter 12V VDC .....	47
10.2	Model-specific Data .....	48
10.3	Dimensions .....	49
10.3.1	Balance with Handler (mm) .....	49
10.3.2	Rack with Controller (mm) .....	50
10.4	Specifications of the RS232C Interface .....	51
10.5	Accessories .....	52
<b>11</b>	<b>Index .....</b>	<b>54</b>

# 1 Your AX Comparator Balance

## 1.1 Introduction

With your purchase of an AX64004, AX32004 or the AX16004, you have chosen a highly professional instrument which will facilitate your comparison weighings up to 64 kg, respectively 32 kg or 16 kg. Our thanks for choosing the METTLER TOLEDO company as your partner.

To ensure you receive the most personal and efficient support possible, we shall give this product special treatment. The comparator balance and weight handler will be completely installed, and you will be shown how to use them, by a specialist who has been specially trained on the comparator balance. The specialist may be from Mettler-Toledo AG, Greifensee (Switzerland), or from your own country. Only this specialist is allowed to adjust the balance.

However, a top-of-the-line balance and optimum installation are just the start. To obtain the best measurement results, close attention must be paid to the balance surroundings. We recommend basement rooms as free from vibrations as possible with a constant temperature and atmospheric humidity.

## 1.2 Conventions and Symbols Used in These Operating Instructions

These operating instructions cover only the operation of the balance controller and preparation of the weight handler for the comparative weighings (see chapter 1.3).

The following conventions apply throughout these operating instructions:

- Key designations are indicated by double angular parentheses (e.g. «**On/Off**» or «»).

## 1.3 When do you Work with Which Controller?

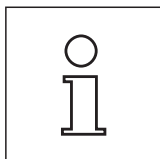

### Balance controller

The balance controller is used together with the "AACOM" firmware to make the preparatory settings for the comparative weighings:

- Controlling the turntable while loading the handler
- Centering the weights
- Making and checking adjustments

### Process controller

The process controller is used together with the "AX-control" software to perform the comparative weighings. Instructions are contained in the separate operating instructions for "AX-control".

If you start the "AX-control" software on the process controller, operation of the balance controller is deactivated.

## 2 Safety Information

### 2.1 Definition of Signal Warnings and Symbols

#### Signal Words

<b>WARNING</b>	for a hazardous situation with medium risk, possibly resulting in severe injuries or death if not avoided.
<b>CAUTION</b>	for a hazardous situation with low risk, resulting in damaged to the device or the property or in losing of data or minor or medium injuries if not avoided.
<b>Attention</b>	(no symbol) for important information about the product.
<b>Note</b>	(no symbol) for useful information about the product.

#### Warning Symbols



General hazard



Electrical shock



Heavy object

#### Mandatory Signs



Wear gloves

### 2.2 Product Specific Safety Notes

Always operate and use your balance only in accordance with the instructions contained in this Operating Instructions. The instructions for setting up your new balance must be strictly observed.

**If the instrument is not used according to these Operating Instructions, protection of the instrument may be impaired and METTLER TOLEDO assumes no liability.**

#### Intended Use

Your balance is used for weighing. Use the balance exclusively for this purpose. Any other type of use and operation beyond the limits of technical specifications without written consent from Mettler-Toledo AG, is considered as not intended.



It is not permitted to use the instrument in explosive atmosphere of gases, steam, fog, dust and flammable dust (hazardous environments).

**CAUTION**

- For use only in dry interior rooms.
- Do not use sharply pointed objects to operate the keyboard! Although your balance is very ruggedly constructed, it is nevertheless a precision instrument. Treat it with corresponding care.
- Do not open the balance: It does not contain any parts which can be maintained, repaired, or replaced by the user. If you ever have problems with your balance, contact your METTLER TOLEDO dealer.
- Use only balance accessories and peripheral devices from METTLER TOLEDO; they are optimally adapted to your balance.

**CAUTION**

Use only the original universal AC adapter delivered with your balance, and check that the voltage printed on it is the same as your local power supply voltage. Only plug the adapter into a socket which is grounded.

**WARNING****Heavy object**

Single person lift could cause injury.  
Do not move or lift this equipment without assistance.  
For moving this equipment ask your METTLER TOLEDO representative.

---



## 3 Setting up the AX Comparator Balance

### 3.1 Delivered Items

The AX comparator weighing system comprises:

- The balance itself with the weight handler
- The balance controller
- The handler controller
- The process controller with the installed (Windows®) "**AX-control**" software for fully-automatic performance and reporting of comparative weighings
- 4 Glass cylinder (Draft shield)
- The controller rack, which ensures that heat-generating components are separated from the weighing unit
- An AC adapter with country-specific power cable
- A cable to connect the weighing unit to the balance controller
- Protective cover for the terminal
- Production certificate
- Operating Instructions Comparator Balances AX64004, AX32004, AX16004
- Operating instructions "AX-control"
- EC declaration of conformity
- Instructions for the "METTLER TOLEDO Standard Interface Command Set" (MT SICS), in English.

The weighing system must be fully cabled before startup.

Connection diagram see chapter 3.3.

### 3.2 Items not Included in Standard Delivery

- Climatic measurement station "Klimet A30" (chapter 10.5)
  - The precision climatic measurement station Klimet A30 can be connected to the computer (Process Controller with "AX-control") via a 2nd serial interface.
- Temperature sensors (chapter 10.5)

### 3.3 Connection Diagram

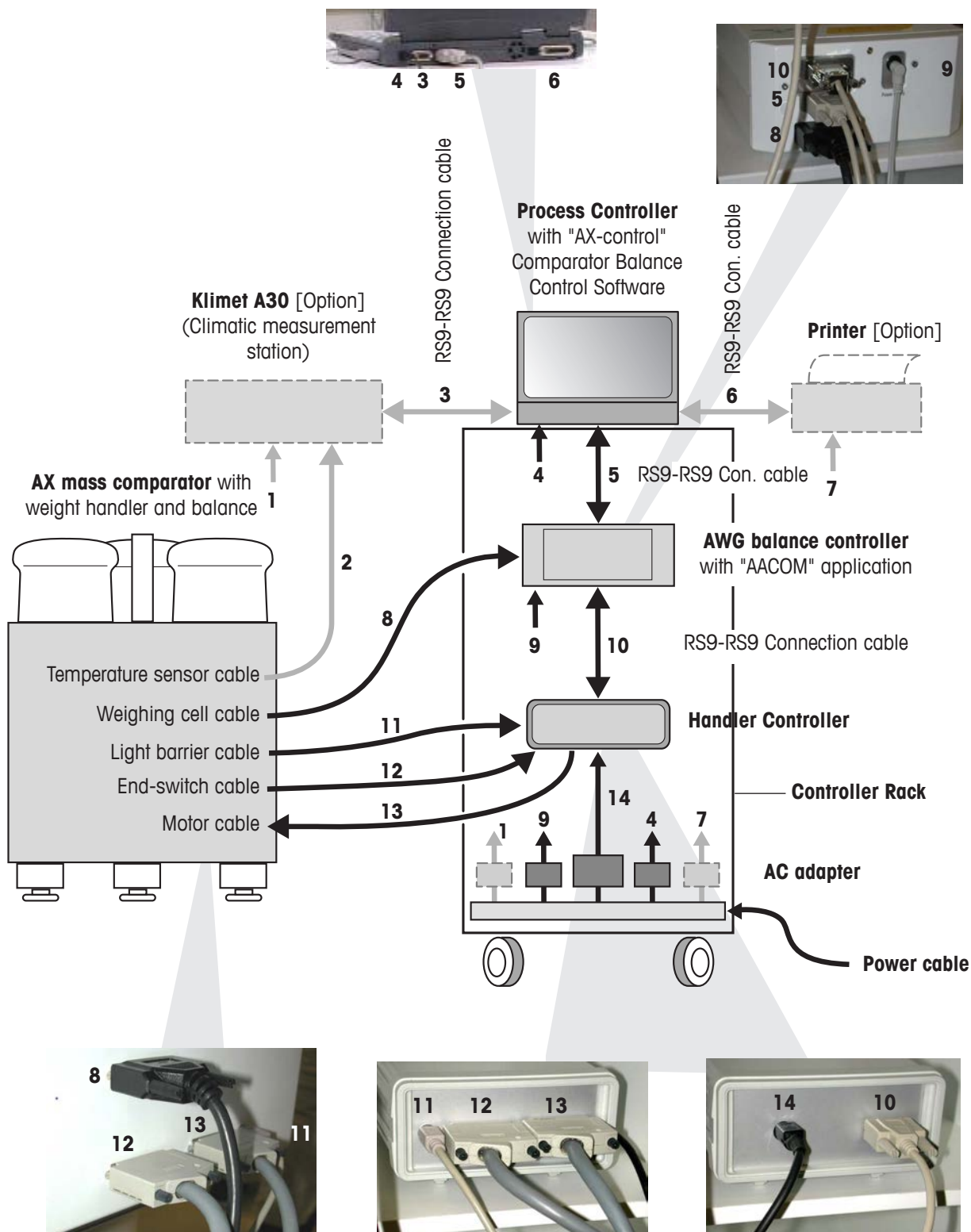

## 3.4 Selecting a Location

Your mass comparator is a precision instrument. Its accuracy and reliability depend on its being placed in an optimal location:

### The surface on which the mass comparator stands should

- transmit as few vibrations as possible,
- not bend during the work,
- be antimagnetic (no steel top),
- be protected against static charging (not plastic or glass),
- preferably be in a corner of the workroom, because the corners are the most rigid points in a building with the least amount of vibration.
- be reserved as the workplace for the comparator balance.

### The workroom should

- be as insensitive as possible to shocks and vibrations,
- have only one door (drafts),
- have as few windows as possible (hazard due to direct sunlight),
- be as free from drafts as possible (important with air conditioning systems).

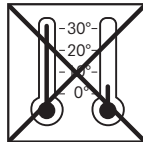

### Temperature

- The room temperature should be as constant as possible to avoid temperature drift of the weighing result,
- avoid weighing in the vicinity of radiators (temperature drifts, air currents).



### Atmospheric humidity

- The relative humidity should be between 45 and 60% (max. fluctuations:  $\pm 2\%$ ).

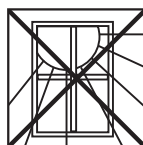

### Light

- Avoid direct sunlight (e.g. wall without window).
- Light fixtures should be at a sufficient distance from the balance to avoid disturbances due to thermal radiation, particularly in the case of light bulbs. Fluorescent lamps are less critical.
- Always leave the light switched on.



### Air

Avoid weighing,

- in the vicinity of air conditioning units or devices with fans (e.g. computers),
- next to a door.

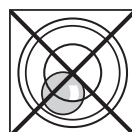
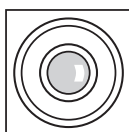

### Leveling

The balance is adjusted to be level when it is delivered. The air bubble must always be in the inner circle of the level indicator.

If ever the air bubble is not in the inner circle of the level indicator, please contact the METTLER TOLEDO distributor responsible for the comparator balance.

## 3.5 Location Change

Before any location change, please contact the METTLER TOLEDO organization or our distributor.

## 3.6 Power Supply

---



### WARNING

#### Risk of electric shock

Your instrument is supplied with a 3-pin power cable with an equipment grounding conductor. Only extension cables which meet this relevant standards and also have an equipment grounding conductor may be used. Intentional disconnection of the equipment grounding conductor is prohibited.

---

- Your balance is delivered complete with two AC adapters and country-specific power supply cables. The AC adapters are suitable for all power supply voltages in the range: 100 – 240 VAC, -10/+15%, 50/60 Hz.
- Check that the local power supply voltage is in this range. **If it is not, DO NOT connect the balance or the AC adapter to the power supply**, and contact your METTLER TOLEDO dealer.

### Attention

- The power plug must be always accessible!
- Take care that AC adapters cannot come into contact with liquids!
- Before operating, check all cables for damage.
- Leave the cables as they were installed by the METTLER TOLEDO technician!

After the balance has been connected to the power supply, it carries out a self test and is then ready for operation.

### Note

To ensure that you can continue to work with the comparator balance if there is a power supply failure, we recommend you to connect the system to an emergency power supply.

### 3.7 Adjusting the Reading Angle and Positioning the Terminal

So that you can work without fatigue, the reading angle of the terminal can be adjusted. For delivery, the terminal is fastened to the balance controller. So that you can arrange your workplace optimally, the terminal can be disconnected and positioned separately.

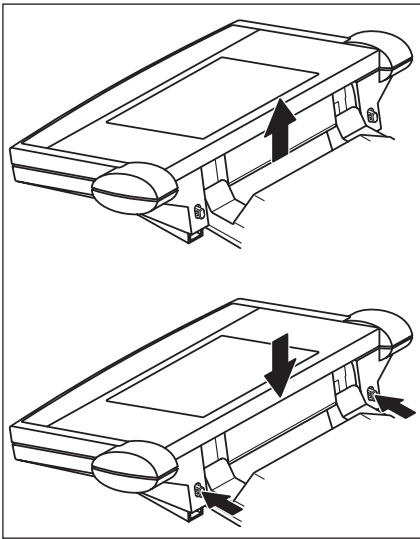

#### Adjusting the reading angle

If you wish to have a steeper reading angle, grasp the back of the terminal and pull it slowly upward until it clicks into the desired position. Three different setting positions are provided.

If you wish to have a flatter reading angle, press the two stop buttons on the back of the terminal and press the terminal downward. Release the two stop buttons and the terminal will then click into the desired position.

Removing the terminal from the balance controller

#### Attention

**Switch off the balance/handler controller.**

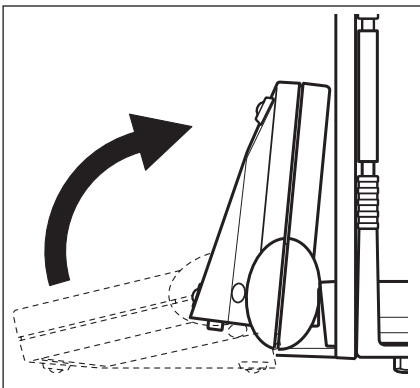

Fold the terminal upward. **Note:** To do this, the terminal must be in the lowest setting position (flattest reading angle).

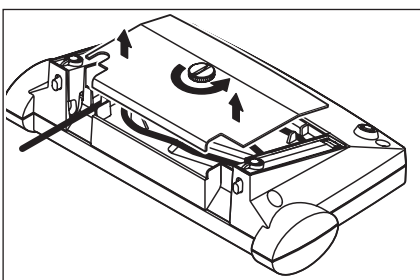

Unscrew the knurled screw underneath the terminal and remove the cover.

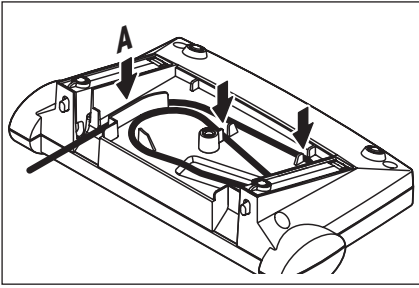

Pull the connecting cable gently out of the tension relievers. Unwind the cable. Replace the cover and fasten it with the knurled screw.

**Note:** Position of the ferrite (A).

Fold the terminal forward again into its normal position.

Grasp the back of the terminal and pull it slowly upward until it clicks into the top position (steepest reading angle).

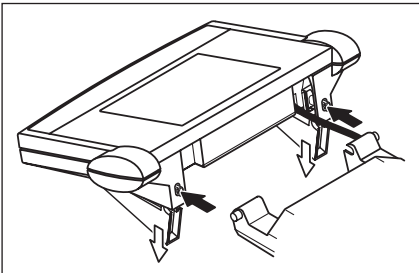

Press the two stop buttons on the back of the terminal and pull the terminal further upward. By doing this you release the two feet of the terminal from their mountings. Place the terminal in the desired location. Press the two stop buttons and lower the feet back into the terminal.

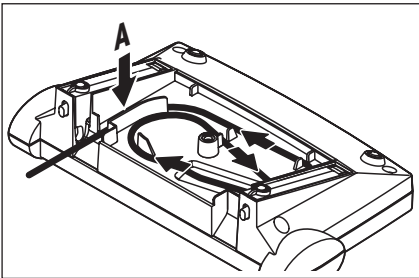

To fasten the terminal again, carry out the procedure in the reverse order. Please refer to the illustration on the left: It shows how to place the cable correctly in the terminal housing.

**Note:** Position of the ferrite (A).

## 4 Starting up the Weighing System

The system will be put into operation for the first time by a specialist from METTLER TOLEDO, who will show you how the individual components of the system must be operated.

### 4.1 Switching the Handler on and off from the Weighing Terminal

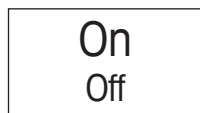

To switch the weighing system on, briefly touch the «On/Off» key. After the balance has been switched on, it carries out a short test. The system is then ready for you to start loading the weight handler and centering the weights (chapter 8).

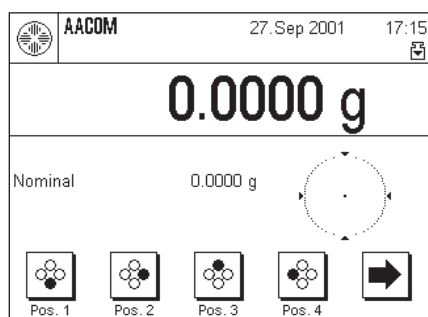

When the system is **switched on for the first time**, the indicator shown at left appears.



Touch the arrow key to change to the second page, which gives you access to further function keys.

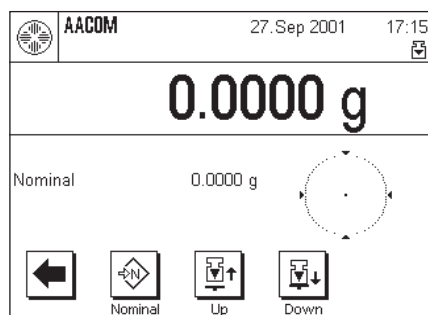

To switch the weighing system off, touch the «On/Off» key and press it until "OFF" appears in the display. The display then goes off, and the balance is switched off.

# 5 Operating the Terminal and Firmware

This chapter describes the operating and display elements on your terminal and explains the concept for operating the firmware on your balance. Please read right through this chapter carefully: It is the basis for all the operating steps described in subsequent chapters.

## 5.1 Overview of the Terminal

In this chapter you will be introduced to the individual keys of the terminal.

In the next chapter, you will find detailed information about the display.

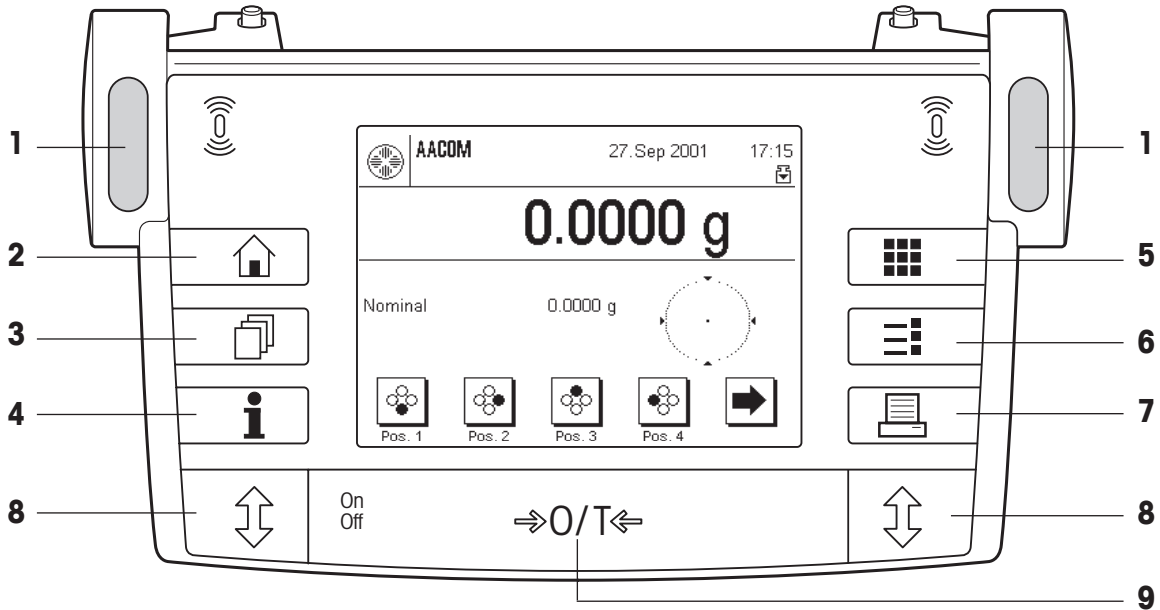

### 1 SmartSens

Has no function on the AX64004, AX32004, and AX16004 comparator balances.



### 2 «» key

Has no function on the AX64004, AX32004, and AX16004 comparator balances.



### 3 «» key

Has no function on the AX64004, AX32004, and AX16004 comparator balances.



### 4 «» key

With this key you can call up a context-sensitive help function at any point. The help text gives a brief explanation of the possibilities available to you at this point (e.g. in a menu). The help window appears over the top of the normal display.



### 5 «» key

This is the key for the "AACOM" application with standard settings.



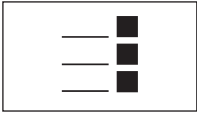

### 6 «» key

The "AACOM" application has a large number of settings which can be used to adapt it optimally to the specific task. Use this key to call up the menus to configure the application.



### 7 «» key

Has no function on the AX64004, AX32004, and AX16004 comparator balances.

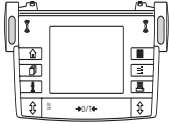

### 8 «» arrow keys

The arrow keys in the dark field of the terminal have no function on the AX64004, AX32004, and AX16004 comparator balances.



### 9 «» key



Use this key to tare (zero set) the balance.

## 5.2 The Display

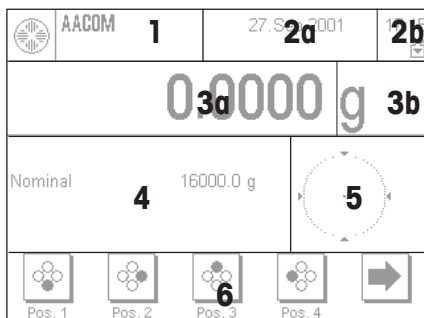
The illuminated graphics display of your terminal is a "Touch Screen", or in other words, a screen which is sensitive to touch. You can use it not only to read data and settings, but by touching the display surface you can also make settings and carry out functions



The display is divided into a number of zones:

- 1 In the upper left-hand corner, the currently active application and the current user profile are displayed. By touching this zone, you can call up a menu in which you can select the desired application (you can also call up this menu with the «» key).
- 2 In the top right-hand section, the date (**2a**) and time (**2b**) are displayed. By touching these zones, you can change the date and time.
- 3 In this zone the current weighing result is displayed. If you touch this zone (**3a**), a small menu appears in which you can select the font for displaying the weighing result. If you touch the weighing unit (**3b**), a window opens in which you can select the desired weighing unit.
- 4 This zone displays additional information (information fields), which make your work easier. Touching this zone opens a menu in which you can specify which information fields and function keys should be displayed (the same menu is also available under the «» key).
- 5 This zone displays the "SmartTrac", which is a graphical weighing-in aid that shows you at a glance how much of the weighing range has already been used and how much is still available. By touching this zone, you can choose between various different display styles for "SmartTrac", turn it off completely, or include a small **stopwatch** in the display.
- 6 This zone is reserved for the function keys, which give you direct access to frequently used functions and settings. If more than 5 function keys are activated, you can use the arrow keys to switch between them.

## 5.3 Balance Control Firmware for the Comparator Balance

The "AACOM" application controls the preparatory setting functions for the subsequent comparative measurements by your comparator balance. The software also makes it possible to adapt the balance to your specific working environment. Please read the following chapters carefully; they form the basis for operating your balance.

The firmware comprises the following levels:

- "AACOM" Application
- Settings





### Application

The comparator balance is shipped from the factory with the "AACOM" application for controlling the handler and adjusting the balance already installed. When the balance is switched on, it is in the "AACOM" application. You can see the application if you touch the «» key. You will find instructions for working with the application in chapter 7 and after.

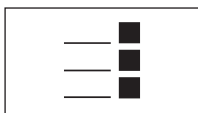

### Settings

The firmware differentiates between two sorts of settings:



- **Application-dependent settings:** The multi-page menu for application-dependent settings can be accessed with the «» key. You will find information about the individual settings that are possible in the chapters relating to the application.



- **System settings** which are not application-dependent. To call up the system settings touch the «» or «» key and then the "System" button. You will find information about the individual settings that are possible in chapter 6.

The diagram below shows the interrelationships between the individual levels of the firmware and gives a first overview of the typical procedure for operating it.

**Work step**

**1. Display application**

**2. Work**

**3. If desired:**  
Change the settings for the application

**4. If desired:**  
Change the system settings

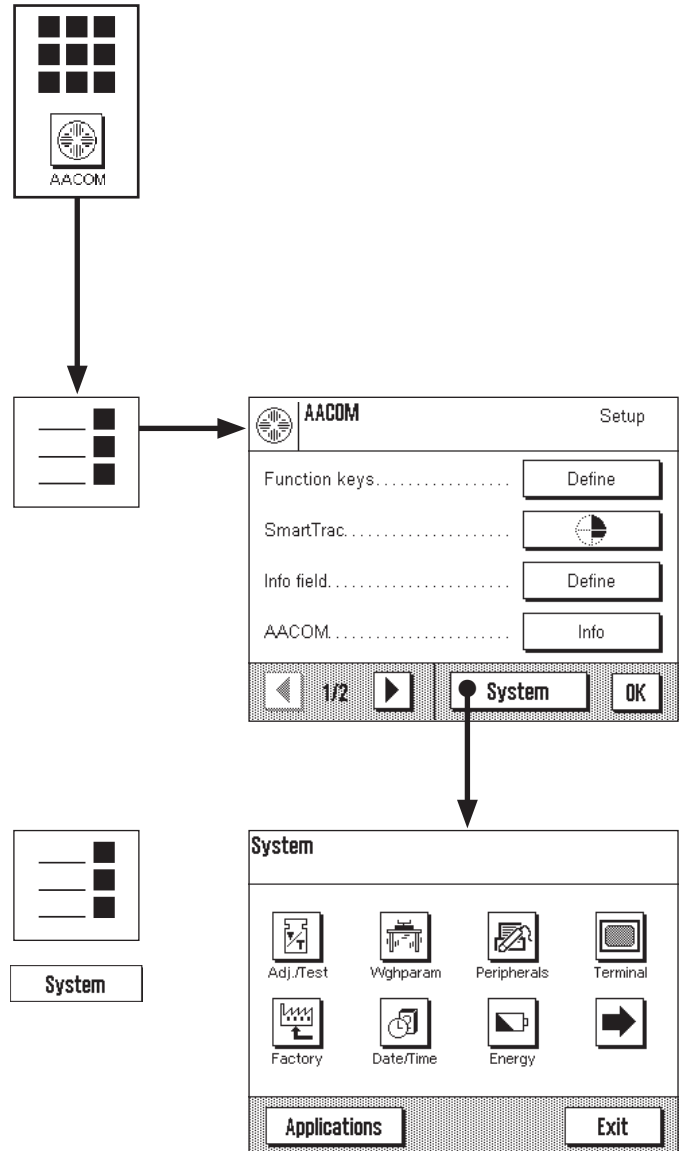

# 6 System Settings

In this chapter you will learn how you can adapt the weighing system to your requirements.

**Note:** You will learn the settings for the application when the application is described.

## 6.1 Calling up the System Settings



You can call up the menu for the system setting either from the settings menu (key «≡») or from the application menu (key «☰»). In both menus, the "System" button can be used for this purpose.

## 6.2 Overview of the System Settings

The system settings are represented by symbols. By clicking on the symbols you can call up the individual settings and change them. The various possible settings are described in the chapters following below.

The following system settings are available:

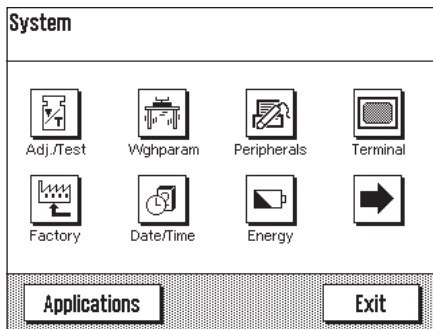

**"Adjust/Test":** Setting for adjustment (calibration), and for the test function to check the adjustment (chapter 6.3).

**"Weighing Parameters":** Settings for adapting the balance to specific weighing tasks (chapter 6.4).

**"Peripherals":** Configures the interface for various peripheral devices (chapter 6.5).

**"Terminal":** Settings for the display (brightness, etc.) and for the behavior of the terminal (chapter 6.6).

**"Factory":** For resetting to the factory settings (chapter 6.7).

**"Date/Time":** To input the date and time, and select the desired display format (chapter 6.8).

**"Energy":** Settings for standby mode and to display the next date for replacing the battery (chapter 6.9).

By touching the button with the arrow symbol, you change over to the second menu page.

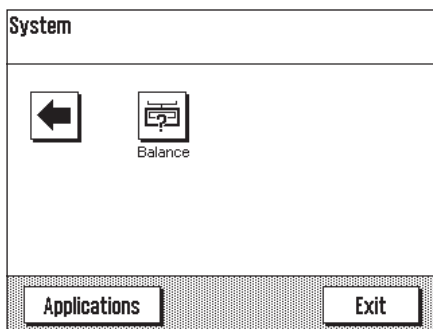

**"Balance":** For specifying the balance identification and inquiring information about the balance (chapter 6.10).

By touching the button with the arrow symbol, you can return to the first menu page. When you have made all the necessary settings, touch the "Exit" button to return to the application. We will explain the various system settings, and how to use the application, in the chapters that follow below.

## 6.3 Settings for Adjustment and Test

You can use these menus to make all the settings associated with adjusting (calibrating) your balance.



Adjust/Test		Setup
History.....	Define	
Protocol.....	Define	
Adjustweight.....	200.0000 g	
Testweight.....	200.0000 g	
		OK

Adjust/Test		Setup
Certificate No.....		
Weight ID.....		
		OK

In the chapters below you will find information on all the possible settings for adjustment and test procedures and for recording them.

### 6.3.1 Displaying the Adjustment History ("History")

History		Setup
History.....	Show	
		OK

In the **"History"** menu you can call up information on adjustment procedures which have already been carried out.

The balance constantly records the data and results of all adjustment procedures. The last 15 procedures can be displayed and printed out.

History		Setup
03 19.Apr 2001	15:07	
ext.	200.0000 g	
23.8 °C		
02 19.Apr 2001	12:13	
ext.	200.0000 g	
23.0 °C		
01 18.Apr 2001	17:23	
ext.	200.0000 g	
21.1 °C		
		Print
		OK

#### "History"

If you touch the **"Show"** button, the selected adjustment procedure is displayed. The display shows the date, time, type of adjustment made, and ambient temperature at the time of the adjustment. You can use the arrow buttons to page up and down between the individual pages (the most recent adjustments are shown at the top of the list, the oldest at the bottom). You can terminate the display by touching **"OK"**.

#### Attention

**"Print"** has no function in the customer configuration!

## 6.3.2 Defining Adjustment and Test Reports

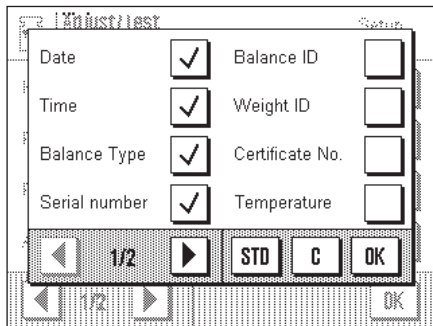

### Attention

#### No function in the customer configuration!

In this menu, which has two pages, you can specify the information to be printed on the adjustment and test reports.

By touching the appropriate buttons, you can activate the desired information. The checked items of information will be included on the reports. By touching "**STD**" you can return to the factory settings. To save the changes, touch "**OK**", (or touch "**C**" to quit the input window without saving the changes).

**Factory setting:** The options shown checked in the illustration on the left.

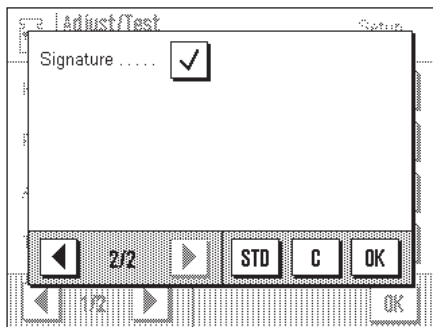

The following items of information can be included in reports:

#### "Date"

Prints the date of adjustment in the defined date format (chapter 6.8).

#### "Time"

Prints the time of adjustment in the selected date format (chapter 6.8).

#### "Balance Type"

This information is stored in the balance and cannot be changed by the user.

#### "Serial number"

This information is stored in the balance and cannot be changed by the user.

#### "Balance ID"

Prints the specified balance identification (chapter 6.10).

#### "Weight ID"

Prints the specified identification of an external adjustment weight (chapter 6.3.6).

#### "Certificate No."

Prints the specified designation for the certificate of an external adjustment weight (chapter 6.3.5).

#### "Temperature"

Prints the temperature at the time of adjustment.

#### "Signature"

Prints an additional line for signing the report.

### 6.3.3 Defining an External Adjustment Weight "Adjustweight"

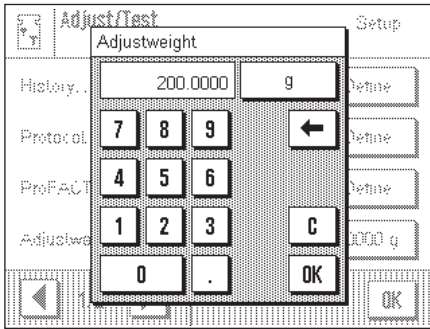

If you work with an external adjustment weight, you can define its weight and unit here. An input window appears which looks like a pocket calculator and can be used like one. Enter the weight of the external adjustment weight. Check the weighing unit: it is shown to the right of the weight. If you touch the weighing unit, the selection of available units appears.

**Note:** The units are not automatically converted, i.e. once you have input a value in a particular unit, this value is unchanged, even if you change the weighing unit.

**Factory setting:** 200.0000 g

### 6.3.4 Defining an External Test Weight "Testweight"

If you work with an external weight to check the adjustment, you can define its weight and unit here. The same input window appears as for the external adjustment weight.

**Factory setting:** 200.0000 g

### 6.3.5 Entering the Weight Certificate Designation "Certificate No."

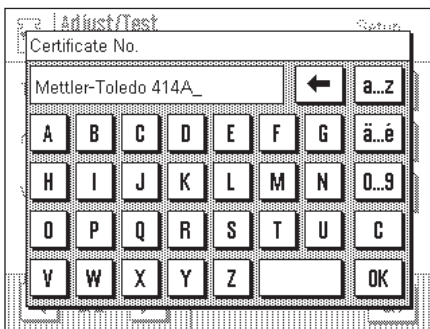

Adjustment weights are generally delivered with a certificate. You can enter the designation and/or number of the certificate delivered with the weight here (max. 20 characters). This makes it possible to unambiguously link the adjustment weight used to a specific certificate. The input window allows input of alphanumeric characters.

**Factory setting:** None

### 6.3.6 Defining the Weight Identification "Weight ID"

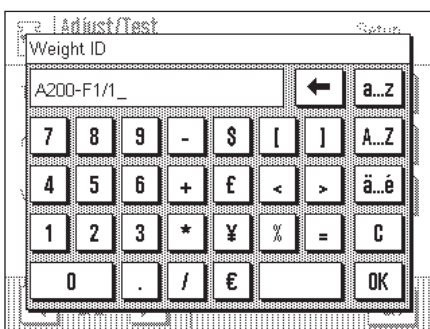

Here you can assign a designation to the adjustment weight used (max. 20 characters). This makes identifying the adjustment weight easier. The same alphanumeric input window appears as for the certificate designation.

**Factory setting:** None

## 6.4 Specifying the Weighing Parameters

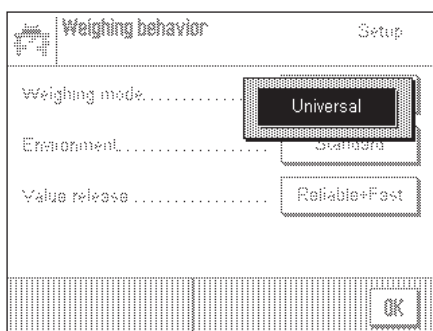
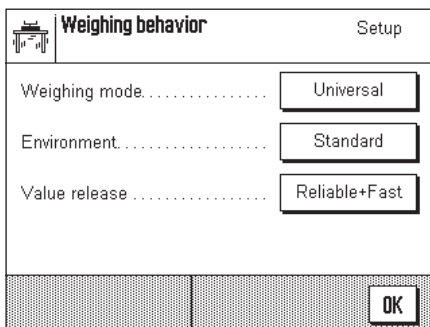

### "Weighing mode"

The **"Universal"** weighing mode is for all normal weighing processes. With this setting the balance responds very quickly to minutest changes in weight.

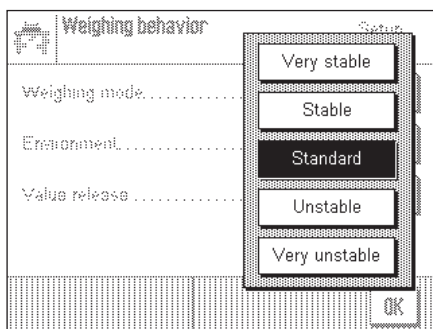

### "Environment"

You can use this setting to adapt the balance optimally to the environmental conditions at the workplace. If you work in surroundings which are practically free from temperature fluctuations, drafts, and vibrations, select "Very stable". In an environment with continuously changing conditions, which is not allowed for a comparator balance, select "Very unstable". In between these two settings there is a choice of three further settings.

**Factory setting:** "Standard"

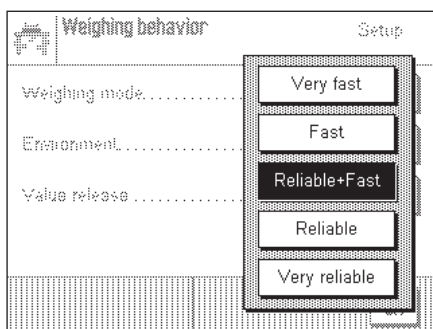

### "Value release"

You can use this setting to specify how rapidly the balance considers the measurement value to be stable and releases it. The "Very fast" setting is recommended if you require rapid results and their repeatability is of secondary importance. The "Very reliable" setting gives very good repeatability of the measurement results, but lengthens the stabilization time. In between these two settings there is a choice of three further settings. **Note:** If you choose a setting other than "Reliable + fast", a window appears with additional information about the selected setting.

**Factory setting:** "Reliable+Fast"



## 6.5 Selecting Peripheral Devices "Peripherals"



Peripherals

**Attention:** The following settings must only be changed by an authorized METTLER TOLEDO employee!

Various peripheral devices can be connected to your balance. In this menu you can specify which device should be connected.

The following settings can be selected:

**"Printer":**

**Attention: No function in the customer configuration!**

**"Host":**

Interface to the process controller where the "AX-control" software for controlling and documenting the comparative weighings is installed.

**"Handler":**

Interface to handler/balance.

**"Host"**

If a device is activated, with the "AX-control" software you can use the "Define" button to set the interface parameters for communication with this device (baud rate, parity, handshake, end-of-line characters, and font). The parameters are preset for the correspondingly optimal METTLER TOLEDO devices (for accessories and options, see chapter 10).

**Factory setting:**

"Host"

(9600 baud, 8 data bits/no parity, XON/XOFF protocol, end-of-line characters <CR><LF> ANSI/WINDOWS-font)

 <b>Handler</b>	Setup
<input type="radio"/> Off	
<input type="radio"/> RS232 fixed .....	Define
<input checked="" type="radio"/> RS232 opt .....	Define
<b>OK</b>	

### "Handler"

To control your handler with the balance controller, select the "RS232 optional" interface.

### Factory setting:

"Handler"

(9600 baud, 8 data bits/no parity, None protocol, end-of-line characters <CR><LF> ANSI/WINDOWS-font)

<b>Handler</b>	Setup
RS232 opt	
Baudrate .....	9600
Parity .....	8Bit/None
Handshake .....	None
End of line .....	<CR><LF>
<input type="button" value="1/2"/>	
<b>OK</b>	

<b>Handler</b>	Setup
RS232 opt	
Char.Set .....	ANSI/WIN
<input type="button" value="2/2"/>	
<b>OK</b>	

## 6.6 Terminal Settings "Terminal"

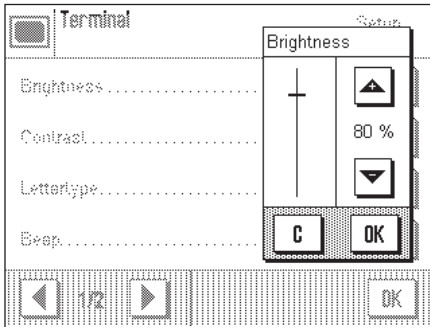
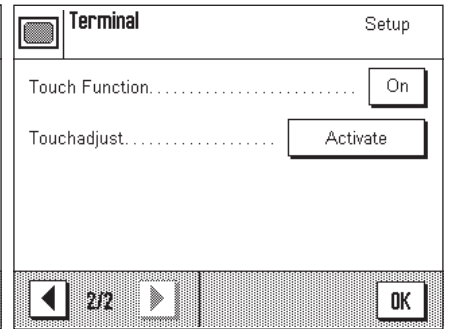
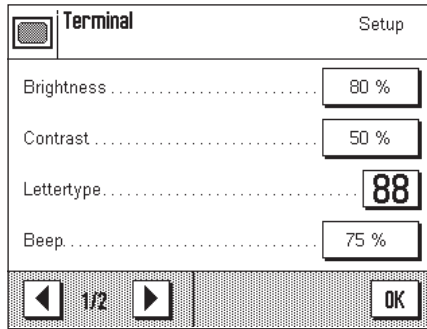

### "Brightness"

Here you can set the brightness of the display. Touch the arrow buttons to adjust the brightness in the range 0 % to 100 % as required. Each time one of the two arrow buttons is touched, the brightness is instantly adjusted so that the change can be seen immediately.

**Factory setting:** 80 %

**Note:** If the balance is not used for 15 minutes, the brightness of the display is automatically reduced. This increases the life of the backlighting. The next time either a key is touched or there is a change in weight, the brightness is changed back to the value selected here.

### "Contrast"

Sets the contrast of the display in the range 0 % to 100 %. Adjustment is done in the same way as for brightness.

**Factory setting:** 50 %

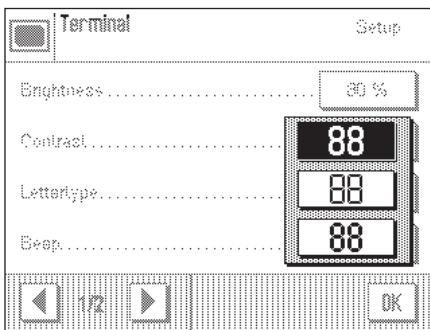

### "Lettertype"

Selects the font for displaying the weighing result. There is a choice of 3 fonts.

**Note:** You can also make this adjustment directly in weighing mode by touching the weighing result. A window appears in which you can select the font directly.

**Factory setting:** Round letters (first setting at top of list)

### "Beep"

Sets the volume of the beep in the range 0 % to 100 %. Setting to 0 % switches the beep off. To make the setting, there is a sliding adjuster similar to those for setting the brightness and contrast.

**Factory setting:** 75 %

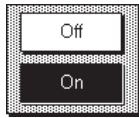

### "Touch Function"

If you switch off the touch function for the "Touch Screen", the display no longer responds to touch in weighing mode, and so you can no longer make settings by touching the display (exception: function keys). **Important:** In setting mode the touch function is always active, because otherwise you can no longer make any settings.

**Factory setting:** "On"

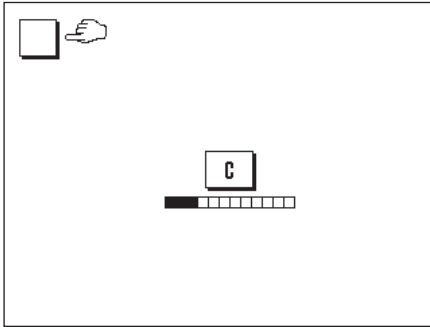

### "Touch adjustment"

If you have the impression that the balance no longer reacts correctly, you can adjust the "Touch Screen" by touching a certain point of the display. When you touch the "Activate" key a window appears and you are prompted to touch the flashing surface. This operation can be repeated several times. (It can be terminated at any time with the "C" key.)

## 6.7 Resetting to the Factory Settings "Factory"

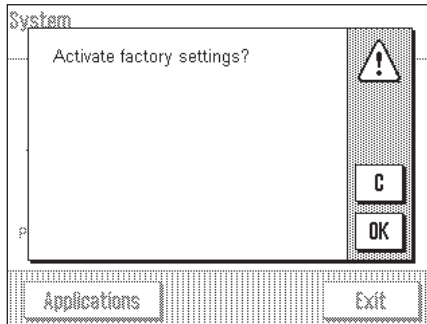

Here you can reset all the settings to the factory settings.

**Attention:** Resetting affects all the settings, application-dependent settings and system settings.

Select either "OK" to reset to the factory settings or "C" to keep the existing settings.

## 6.8 Date and Time "Date/Time"



Date/Time Setup	
Date Format .....	D.MMM YYYY
Date .....	3.4.2001
Time Format .....	24:MM
Time .....	16.47.35
OK	

Date/Time Setup	
Date Format .....	D.MMM YYYY
Date .....	3.4.2001
Time Format .....	24:MM
Time .....	16.47.35
OK	

### "Date Format" (for the display)

The following date formats are available:

"D.MMM.YYYY" Example: 3. APR 2001

"MMM D YYYY" Example: APR 3 2001

"DD.MM.YYYY" Example: 03.04.2001

"MM/DD/YYYY" Example: 04/03/2001

**Factory setting:** "D.MMM.YYYY"

Date/Time Setup	
Date [DD.MM.YYYY]	D.MMM YYYY
03.04.2001	3.4.2001
7 8 9	24:MM
4 5 6	16.47.35
1 2 3 C	
0 . OK	
OK	

### "Date"

Sets the current date. An input window appears which looks like a pocket calculator and can be used like one. Enter the current date in format **day-month-year (DD.MM.YYYY)**, irrespective of which date format you selected for the display.

**Note:** You can also make this adjustment directly in weighing mode by touching the date. A window appears in which you can enter the date directly.

Date/Time Setup	
Date Format .....	D.MMM YYYY
Date .....	3.4.2001
Time Format .....	24:MM
Time .....	16.47.35
OK	

### "Time Format" (for the display)

Here you can specify the format to be used for displaying the time. The following time formats are available:

"24:MM" Example: 16:47

"12:MM" Example: 4:47 PM

"24.MM" Example: 16.47

"12.MM" Example: 4.47 PM

**Factory setting:** "24:MM"

Date/Time Setup	
Time [24.MM.SS]	D.MMM YYYY
16.51.29	3.4.2001
7 8 9 +1H	24:MM
4 5 6 -1H	16.47.35
1 2 3 C	
0 . OK	
OK	

### "Time"

Sets the current time. Enter the current time in **24-hour format (24.MM.SS)**, irrespective of the time format you selected for the display. The input window is the same as for the date, except that there are two additional buttons "+1H" and "-1H" which can be used to put the time forward or back by one hour respectively. This makes it possible to change over quickly to summer time or winter (standard) time. **Note:** You can also set the time directly in weighing mode by touching the time in the display.

## 6.9 Energy-saving Function and Battery Change Date "Energy"

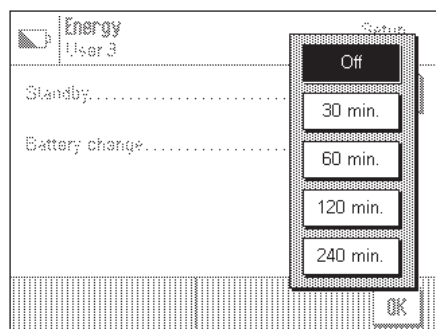
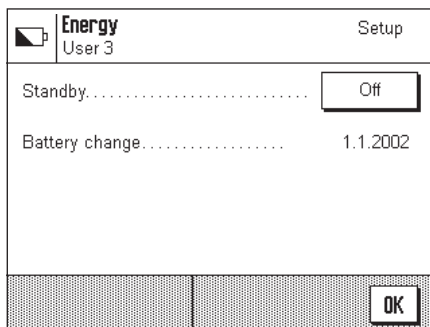

### "Standby"

Here you can specify how long the balance can remain unused before it switches over to "Standby" mode. "Standby" mode is the same status as when the balance is switched off with the «On/Off» key. To switch the balance on again, the «On/Off» key has to be pressed.

**Factory setting:** "Off" ("Standby" mode deactivated)

**Note:** Irrespective of the setting for "Standby" mode, the brightness of the display is automatically reduced if the balance is not used for 15 minutes. This increases the life of the backlighting. The next time either a key is touched or there is a change in weight, the brightness is automatically changed back to the value selected here.

### "Battery change"

Your balance has a memory which is protected by a battery so that all the settings are saved even if the balance is disconnected from the power supply. The average service life of the battery is about 5 years. The battery can only be changed by a service technician. After the battery has been changed, the service technician enters the date for the next battery change. When this date is reached, the battery symbol appears under the time display in weighing mode to remind you that the battery should be replaced.

**You cannot make any changes in this field:** You can only check the date when the next battery change is due.

## 6.10 Balance Information "Balance"

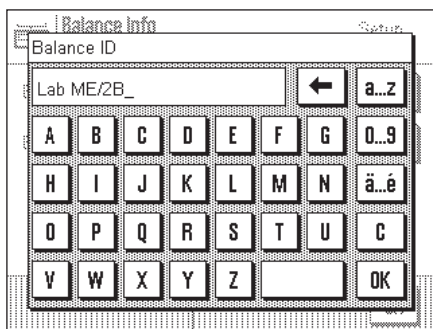
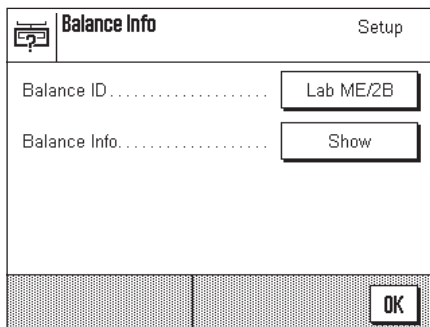
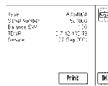

### "Balance ID"

Here you can assign an identification to the balance (up to a maximum of 20 characters). This can be used, for example, to identify the balance within a network. This makes it possible to link the records and reports to a specific balance.

**Factory setting:** No balance identification

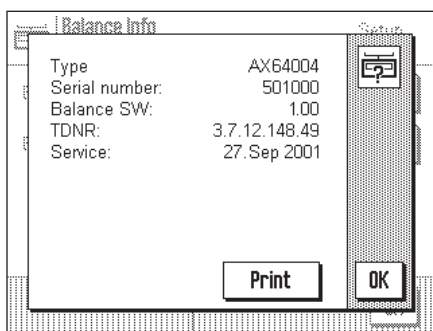

### "Balance info"

This window displays important information about your balance, such as balance type, serial number, etc. You should always have this information ready when you contact your METTLER TOLEDO authorized representative. The date for the next service is also displayed.

# 7 The "AACOM" Application

The "AACOM" application is used to operate the weight handler. In this chapter you will find an introduction to the "AACOM" application. You will find information for practical work with "AACOM" and about the various settings. (You will find information about system settings which do not depend on "AACOM" in chapter 6).

## 7.1 Selecting the Application



If the "AACOM" application is not already active, touch the «» key. In the selection window, touch the symbol for the "AACOM" application. The system loads the application and is then ready for you to enter your settings.

## 7.2 Settings for the "AACOM" Application

### 7.2.1 Overview

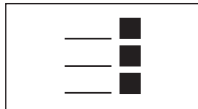

The application-dependent settings can be accessed with the «» key. When this key is pressed, the first of 2 menu pages with application-dependent settings is displayed.

**Note:** You can change some of the most frequently used settings directly by touching the corresponding zone in the display (chapter 5.2).

The following settings are available for the "AACOM" application:

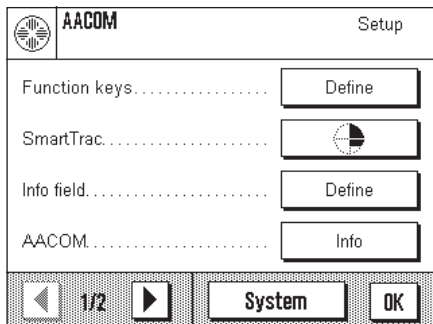

**"Function keys":**

Here you can specify which function keys should appear at the bottom edge of the display. These keys allow direct access to certain functions (chapter 7.2.2).

**"SmartTrac":**

Selects the display mode for the graphical weighing-in aid or to show a stopwatch (chapter 7.2.3).

**"Info field":**

Here you can specify which information fields should be displayed (chapter 7.2.4).

**"AACOM":**

Here you can obtain information about the balance type, handler SW, balance SW, and balance serial number.



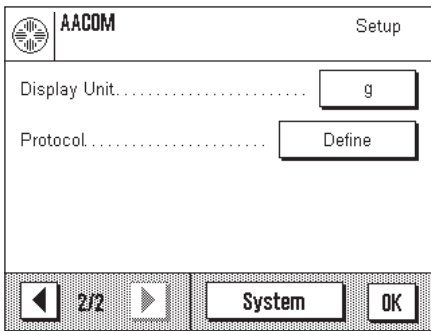

Touching the buttons with the arrow symbols returns you to the second menu page.

- "Display Unit":** Specifies the unit for displaying the results (chapter 7.2.6).
- "Protocol":** Specifies the information to appear on the weighing reports (chapter 7.2.7).

By touching the button with the arrow symbol you can return to the first menu page.

When you have made all the necessary settings, touch the "OK" button to return to the application.

In the chapters following below, we will give you a detailed introduction to the various settings for the "AACOM" application.

### Recording the application-specific settings

#### Attention

#### No function in the customer configuration!

When you are working in the menus for the application-specific settings, you can record the settings at any time by touching the «☰» key (provided a printer is attached and activated as output device in the system settings).

The application-specific settings printed out are those of the currently active user profile.

## 7.2.2 Select "Function Keys"

Function keys make it possible for you to access certain functions and settings of the application directly. The function keys are displayed within the application at the bottom edge of the display (see chapter 5.2). Touching a key initiates the corresponding function.

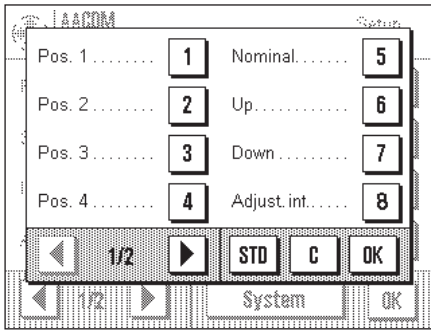

In this menu you specify which function keys should be available in the application. You can call up the menu for the function keys directly from the application by touching the corresponding zone in the display (chapter 5.2).

The function keys are displayed in the application with a number. The numbers determine the sequence of the function keys in the display. If you activate or deactivate a function key by touching it, the sequence of the keys is automatically updated. To specify a completely new sequence, first deactivate all the function keys and then activate them in the desired sequence. You can use "STD" to reset to the factory settings. Touch "OK" to save the changes (or touch "C" to quit the input window without saving the changes).

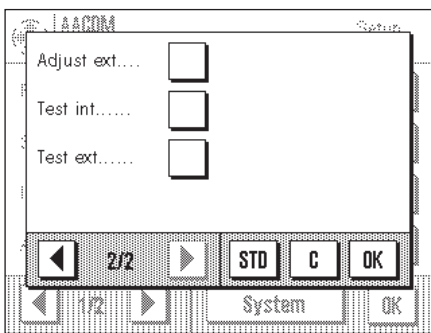

The following function keys are available:

- "Pos. 1":** The turntable moves the weight in position 1 to the measuring position.
- "Pos. 2":** The turntable moves the weight in position 2 to the measuring position.
- "Pos. 3":** The turntable moves the weight in position 3 to the measuring position.
- "Pos. 4":** The turntable moves the weight in position 4 to the measuring position.
- "Nominal":** You can use this function key to specify the nominal weight (chapter 8.2.1).
- "Up":** After the weight has been measured or centered, the turntable is moved up from the lowered measuring position.
- "Down":** To measure or center the weight, the turntable is moved down.
- "Adjust.int" and "Adjust.ext":** Adjusts the balance using an internal or external adjustment weight. You will find instructions for making and recording the adjustment in chapter 8.3.2.
- "Test.int" and "Test.ext":** Checks the balance adjustment using an internal or external test weight. You will find instructions for carrying out the checks in chapter 8.3.3.
- Factory setting:** "Pos. 1", "Pos. 2", "Pos. 3", "Pos. 4", "Nominal", "Up", "Down", "Adjust.int" are activated.

### 7.2.3 "SmartTrac" and Stopwatch

"SmartTrac" is a graphical weighing-in aid. When the comparator balance is switched on, "SmartTrac" may give a slightly false reading, depending on the weighing range of your balance. If there is an over- or underload, an error message appears (chapter 9). "SmartTrac" appears in the application at the right-hand side of the display below the weighing result (chapter 5.2).

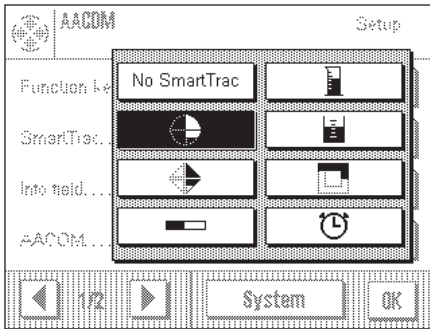

In this menu you can select the display mode for "SmartTrac" or switch it off. Instead of "SmartTrac", you can also display a stopwatch.

**Note:** You can also call up this menu directly from the application by touching the corresponding zone of the display (chapter 5.2).

To make the "SmartTrac" selection, a menu is available which you can call up either with the «≡» key or by directly touching the "SmartTrac" zone in the display.

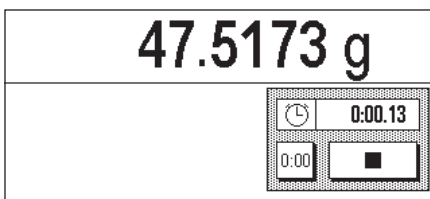

#### Stopwatch

The stopwatch is mentioned here for the sake of completeness, because it can be activated in the same menu as "SmartTrac". The stopwatch supports you when performing time-critical tasks. To start the stopwatch, touch the key with the arrow symbol. Touching the key again stops the stopwatch. The "0:00" key is used to reset the stopwatch to zero.

**Factory setting:** "SmartTrac" 1 is switched on

### 7.2.4 Select Information Field "Info Field"

The Information field gives you information about the nominal value that has been set. The information field is displayed in the application below the weighing result (chapter 5.2).

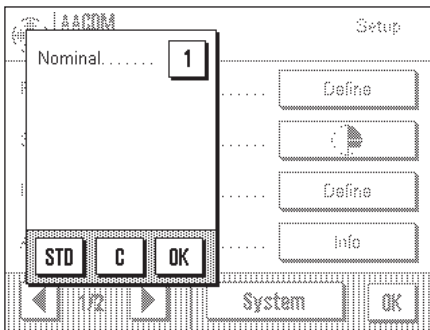

In this menu you specify whether the information fields should be shown in the application. You can call up the menu for the information field directly from the application by touching the corresponding zone of the display (chapter 5.2).

The information field and its corresponding number is displayed in the application. You can use "STD" to reset to the factory settings, or touch "C" to quit the input window without saving the changes. If you wish to save your changes, touch "OK".

The following information field is available:

**"Nominal":** This information field displays the nominal weight that was input using the function key with the same name.

**Factory setting:** "Nominal" is activated.

## 7.2.5 AACOM Information

Information about settings in the "AACOM" application.

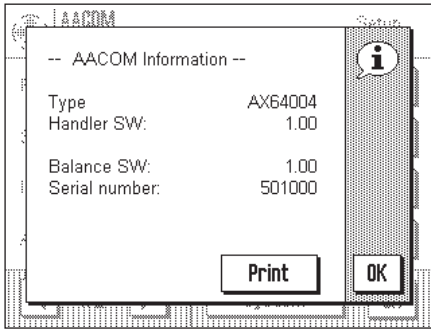

You will see the following information:

"Type"	Displays the comparator balance type.
"Handler SW"	Displays the handler firmware.
"Balance SW"	Displays the balance firmware.
"Serial number"	Displays the serial number of the comparator balance.

## 7.2.6 Selecting Weighing Unit "Display Unit"

In the "Display Unit" menu you specify which weighing unit you wish to work with (chapter 7.2.1).

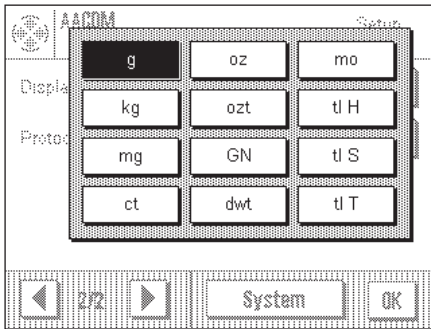

When the "Display Unit" is changed, the current weighing result, the saved weighing results (sum), and the statistical values are displayed in the new unit.

**Note:** The nominal weight is still displayed in the unit which was selected at the time of definition.

**Factory setting:** "Display Unit": "g" (gram)

## 7.2.7 Define Report "Proocol"

### Attention

#### No function in the customer configuration!

In this menu you specify the information to appear on the reports.

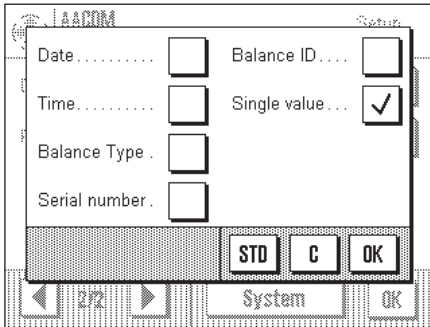

"**Define**" takes you to the submenu in which you can specify the options for reporting the individual values and for the weighing result.

### Options for the report

In this submenu you specify the information to be printed in the weighing record.

By touching the corresponding box, you activate the desired information. The checked information will be printed on the record. You can use "STD" to reset to the factory settings, or touch "C" to quit the input window without saving the changes. If you wish to save your changes, touch "OK".

The following options are available:

- |  |  |
|--|--|
| <b>"Date"</b> and <b>"Time"</b> :                  | The current date and time are printed out (chapter 6.8).   |
| <b>"Balance Type"</b> and <b>"Serial number"</b> : | This information is read from the electronics system of the balance and cannot be changed by the user.   |
| <b>"Balance ID"</b> :                              | The specified balance identification is printed out (chapter 6.10).  |
| <b>"Single value"</b> :                            | Here you specify whether individual values are to be printed on the record, or only the final result (e.g. a series of comparative weighings). |
| <b>Factory setting:</b>                            | "Single value" is activated  |

# 8 Working with the "AACOM" Application

## 8.1 Preparing for Centering the Weights

### 8.1.1 Load the Turntable

#### Attention

- Make sure the turntable is in the upper position.
- Make sure the turntable and weights have been cleaned and are free of dust.
- Always wear gloves when handling the weights.
- When placing the weights on the turntable, position them as centrally as possible on the respective grids. This will reduce the number of centering operations you have to do.

#### Place the weights on the turntable

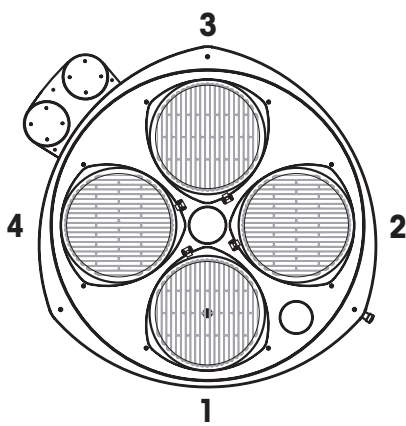

Position 1: Known reference weight  
Positions 2 to 4: Weights to be compared

### 8.1.2 Centering Principle with Built-in Levelmatic

1. Lower the turntable.
2. The curvature of the weighing pan automatically moves the weight toward the center.
3. Raise the turntable.

Repeat this procedure until the weight no longer visibly changes position. With good pre-positioning this should be after about 3 operations.

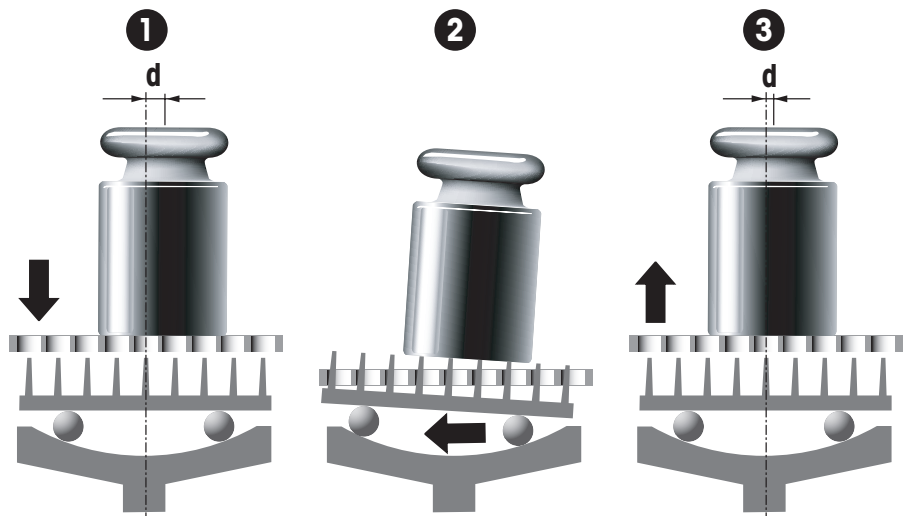

## 8.2 Centering the Weight with the Balance Controller

This chapter explains how the "AACOM" application can be used to control the weight handler.

With this application you control the turntable, while the weights are being loaded, and the centering of the weights.

**Important:** When placing the weights on the turntable, position them as centrally as possible on the respective grid. This will reduce the number of centering operations you have to do (chapter 8.1).

### 8.2.1 Enter the Nominal Weight



First press the "Nominal" function key.

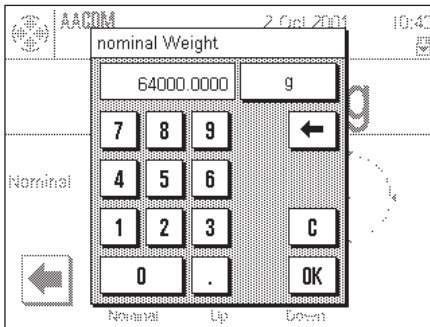

Enter the nominal weight.

Confirm your input with the "OK" key.

This operation activates the respective dialing weights.

The nominal weight you entered is displayed in the information field.

### 8.2.2 Centering

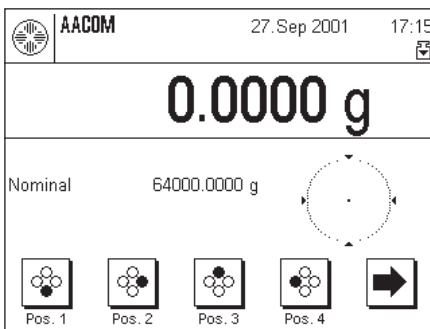

Centering is done with the built-in Levelmatic. You start each operation manually. Levelmatic centers the selected weight in a small number of operations which you initiate (about 3).

1. Touch one of the function keys for **position 1, 2, 3, or 4** to determine the weight to be centered.

The turntable moves until the selected weight (position) is in the centering position, which is also the measuring position.

2. Touch the "**Down**" key to lower the turntable.

When the turntable has been lowered, the first pass at centering the weight is performed.

3. When this operation is complete, touch the "**Up**" key.

The weight is then lifted.

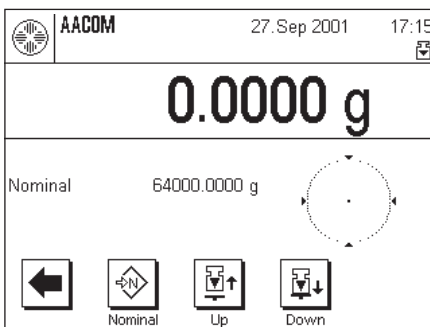

Repeat this procedure until the weight no longer moves. With good pre-positioning, this is after about 3 operations.

**Note:** To perform the comparative measurements, you use the "AX-control" software of the process controller (see also chapter 1.3).

You will find information about how to use the "AX-control" software in the separate "AX-control Operating Instructions" included with the delivery.

**Attention:** When performing comparative measurements, you must always have the 4 glass cylinders (draft shields) in place.

## 8.3 Adjusting the Comparator Balance and Checking the Adjustment

Before you can start the adjustment and the adjustment check with the function keys, you must first activate these 2 function keys (see "Function keys", chapters 7.2.1 and 7.2.2).

### 8.3.1 Adjustment with Internal Weight

By touching this function key, you start adjustment (calibration) of the balance using the built-in calibration weight.



You can hear the motor placing the internal weight on the weighing pan and then removing it again. While adjustment is taking place, the window shown on the left is opened. The symbols are animated so you can follow the adjustment process visually while it is taking place. You can terminate the adjustment process at any time by touching the "Cancel" key.

When the adjustment is complete, one or other of the following messages appears:

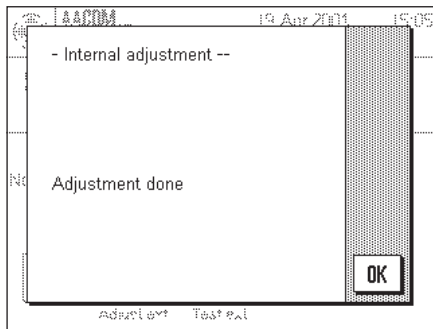

**Adjustment successfully completed.** Touch "OK" to return to the application.

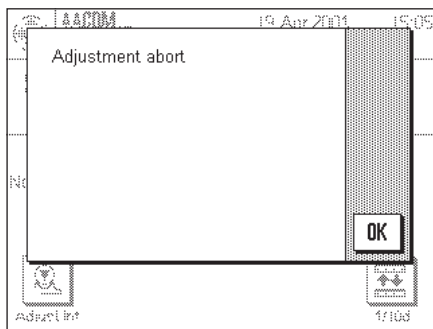

**An error has occurred while adjusting and the adjustment has been terminated.** This message also appears if you terminate the adjustment yourself. You can repeat the adjustment process or return to the application by touching "OK".



### 8.3.2 Adjustment with External Weight

**Important:** To perform the external adjustment, either a test weight or the reference weight must be placed on the grid (in the measuring position). Center this weight according to the description in chapter 8.2!

**This is because** the external adjustment weight (calibration weight) can't be transported directly from the grid to the Levelmatic centering device.



Adjust.ext

Touch this key to start adjustment of the balance with external calibration weight.

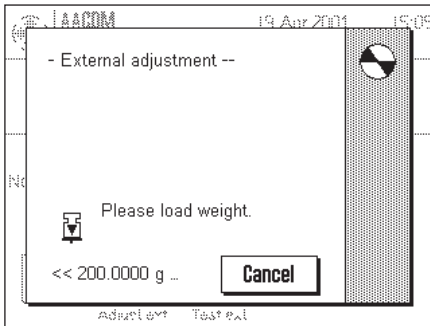

Wait until you are prompted to load the calibration weight. The weight required is shown at the bottom of the window. Place the calibration weight on top of the centered weight.

**Important:** Make sure you load the correct calibration weight, otherwise the calibration process will terminate with an error message. The calibration weight can be specified in the system settings (chapter 6.3).

When you have loaded the calibration weight, you must put the glass cylinder (draft shield) into position.

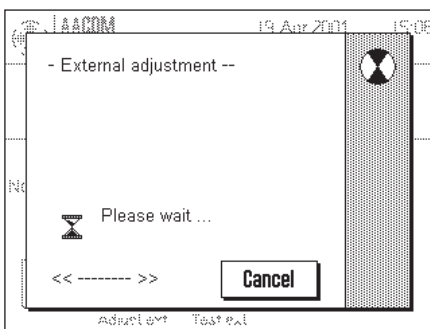

While the adjustment is taking place, the window at left is displayed. You can terminate the current adjustment process at any time with the "Cancel" key.

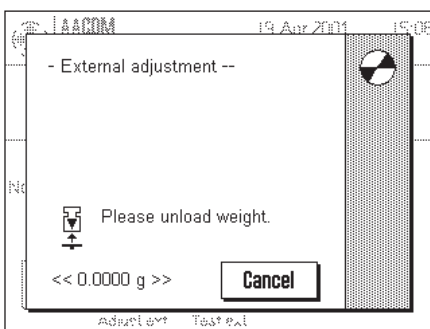

When the adjustment process is finished, you are prompted to remove the weight. Remove the adjustment weight.

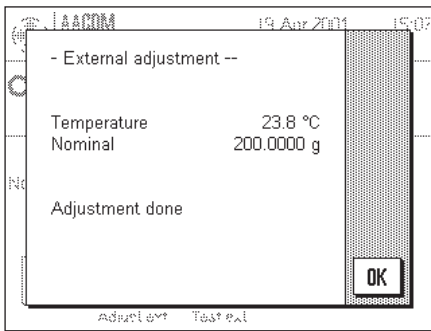

The comparator balance confirms that the adjustment was successfully completed. Touch the "OK" key to return to the application.

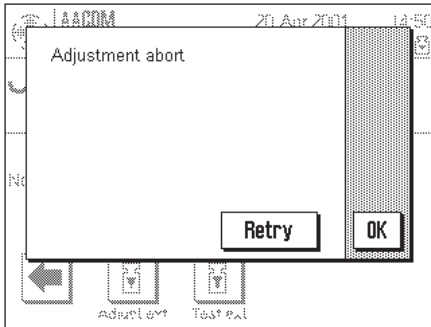

This message indicates that an error occurred and the process was terminated. The message also appears if you terminate the adjustment yourself. You can repeat the adjustment operation with "Retry", or touch "OK" to return to the application.

### 8.3.3 Checking the Adjustment with the Internal Weight



By touching this function key, you can use the internal weight to check the correct adjustment (calibration) of your balance.

The checking procedure is similar to the procedure for adjustment using the internal weight (chapter 8.3.1).

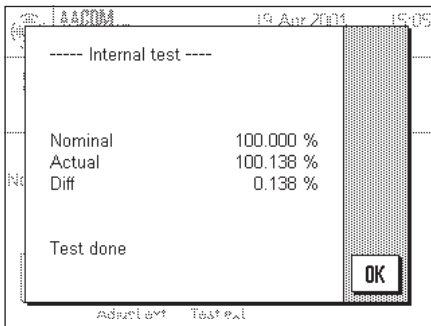

The successful conclusion of the checking procedure is confirmed with the window shown on the left.

If an error occurs during adjustment, a corresponding message appears.

### 8.3.4 Checking the Adjustment with the External Weight



By touching this key you can use the external weight to check that your comparator balance is correctly adjusted (calibrated).

The checking procedure is similar to the procedure for adjustment with the external weight (chapter 8.3.2).

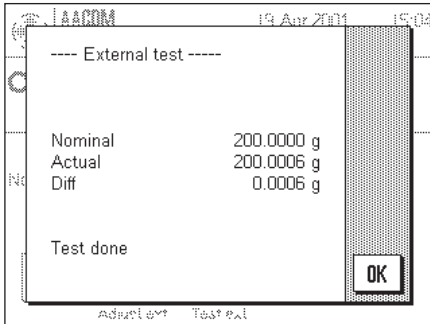

Successful completion of the checking operation is confirmed with the message in the window at left.

If the checking operation is terminated because of an error, a corresponding message is displayed.

## 9 Further Important Information

### 9.1 Error Messages Occurring During Normal Operation

Most error messages are displayed as clear text, and usually with instructions for correcting the fault. Error messages of this type are self-explanatory and therefore not mentioned below.

The following two error messages can appear instead of the weighing result:

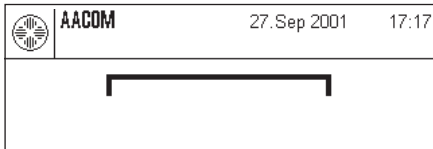

#### Overload

The weight on the pan exceeds the weighing capacity of the balance, or you have entered an incorrect nominal weight value. Raise the turntable and check that the nominal value matches the weight.

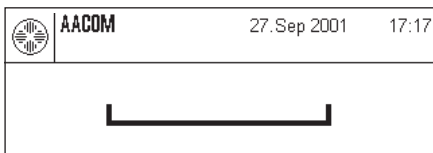

#### Underload

Either the weight on the turntable is less than the minimum weighing load, or you have input an incorrect nominal value. Raise the turntable and check that the nominal value matches the weight.



#### Taring or zeroing was interrupted by touching the «On/Off» key

Taring or zeroing was interrupted by touching the «On/Off» key. The message is automatically extinguished after 3 seconds. Following this, tare/zero again.

### 9.2 Further Error Messages

During normal operation, the following error messages should not occur. If the message re-appears after switching the balance off and on again, please contact the customer service department of your dealer.

#### "ERROR 4"

Cause: EAROM error  
Occurs: When switching on (connecting to the power supply or switching on from standby mode)  
Correction: Switch balance off and on again. If the message re-appears, notify customer services.

#### "ERROR 6"

Cause: No primary calibration  
Occurs: When connecting the comparator balance to the power supply  
Correction: Notify customer services.

## 9.3 Cleaning

Care must be taken to use only weights that are clean and free of dust. It is especially important to check that the underside of the weight, on which it stands, is free of dust. If necessary, clean with a soft brush.

The turntable and the supporting grids for the weights can also be cleaned with a soft brush.

### Please observe the following notes



#### WARNING

##### Risk of electric shock

- The balance must be disconnected from the power supply.
- Use only the power cable from METTLER TOLEDO, if it needs to be replaced.
- Take care that no liquids can penetrate into the weighing system, the controller rack, the controllers it contains, or the AC adapter!
- Never open the comparator balance, the terminal, or the AC adapter: they do not contain any components that can be cleaned, repaired, or replaced by the user!



#### CAUTION

##### Damage of device

Never use cleaning agents containing solvents or abrasives as these can cause damage!



#### ATTENTION

##### Wear gloves

Always wear gloves when handling the weights and the glass cylinders.

### Cleaning

Your comparator balance is made from high quality, resistant materials and can therefore be cleaned with a commercially available, mild cleaning agent.

#### Note

Ask your METTLER TOLEDO dealer about servicing possibilities – regular servicing by an authorized service technician guarantees consistent weighing accuracy for years.

## 9.4 Disposal



In conformance with the European Directive 2002/96/EC on Waste Electrical and Electronic Equipment (WEEE) this device may not be disposed of in domestic waste. This also applies to countries outside the EU, per their specific requirements.

Please dispose of this product in accordance with local regulations at the collecting point specified for electrical and electronic equipment.

If you have any questions, please contact the responsible authority or the distributor from which you purchased this device.

Should this device be passed on to other parties (for private or professional use), the content of this regulation must also be related.

Thank you for your contribution to environmental protection.

# 10 Technical Data and Accessories

---



## CAUTION

Use only with tested AC Adapters with SELV output current.

---

## 10.1 General Data

### Power supply balance

- AC adapter: Primary: 100–240 V AC, -15%/+10%, 50–60 Hz  
Secondary: 12 V DC, 2.5 A (with electronic overload protection)
- Power supply to the balance: 12 V DC  $\pm$  3%, 1.0 A, maximum ripple 80 mVpp  
Ensure correct polarity 
- Cable to AC adapter: Design: 3-core, with country-specific plug

### Power supply handler

- AC adapter: Primary: 100–240 V AC,  $\pm$ 10%, 47–63 Hz  
Secondary: 24 V DC, 2.08 A (with electronic overload protection)
- Power supply to the handler: 24 V DC, 1.5 A
- Cable to AC adapter: Design: 3-core, with country-specific plug

### Protection and standards

- Overvoltage category: Class II
- Degree of pollution: 2
- Standards for safety and EMC: See Declaration of Conformity
- Range of application: For use only in closed interior rooms

### Environmental conditions

- Ambient temperature: 17 - 27 °C
- Max. temperature change: 0.5 °C/12h
- Relative air humidity: 45% - 60%, non-condensing
- Warm-up time: At least 120 minutes after connecting the balance to the power supply; when switched on from standby-mode, the balance is ready for operation immediately.

### Materials

- Housing: Aluminum sheet, painted
- Terminal: Die-cast zinc, lacquered, and plastic

### 10.1.1 Explanatory Notes for the METTLER TOLEDO AC Adapter 12V VDC

The certified external power supply which conforms to the requirements for Class II double insulated equipment is not provided with a protective earth connection but with a functional earth connection for EMC purposes. This earth connection IS NOT a safety feature. Further information about conformance of our products can be found in the brochure "Declaration of Conformity" which is coming with each product.

In case of testing with regard to the European Directive 2001/95/EC the power supply and the balance have to be handled as Class II double insulated equipment.

Consequently an earth bonding test is not required. Similarly it is not necessary to carry out an earth bonding test between the supply earth conductor and any exposed metalwork on the balance.

Because the balance are sensitive to static charges a leakage resistor, typically 10 k $\Omega$ , is connected between the earth connector and the power supply output terminals. The arrangement is shown in the equivalent circuit diagram. This resistor is not part of the electrical safety arrangement and does not require testing at regular intervals.

#### Equivalent circuit diagram

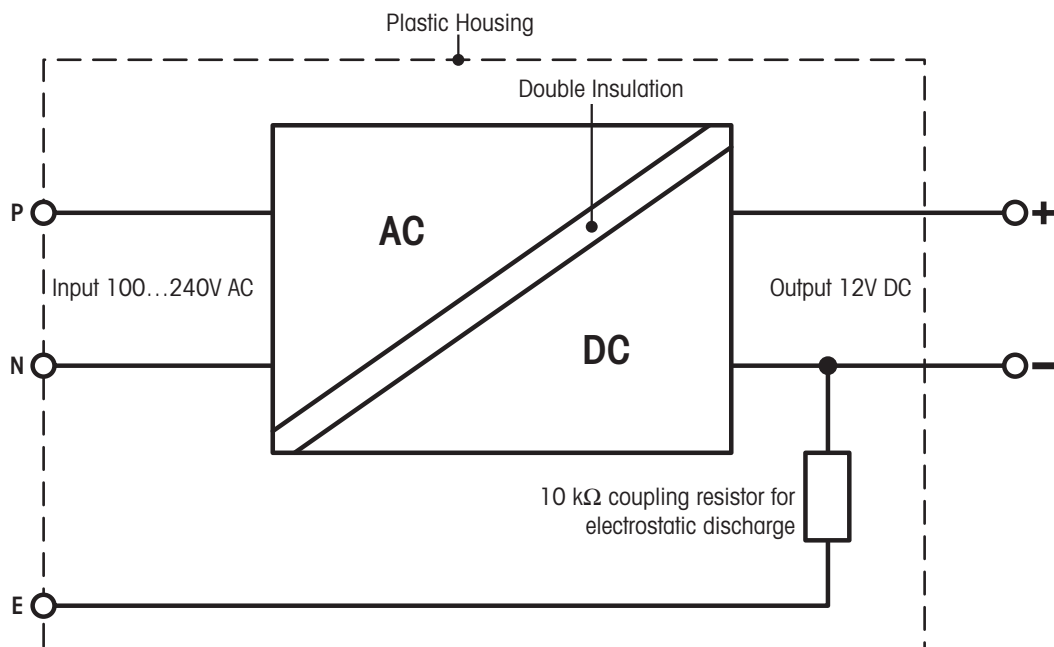

## 10.2 Model-specific Data

	<b>AX64004</b>	<b>AX32004</b>	<b>AX16004</b>
Readability	0.1 mg	0.1 mg	0.1 mg
Maximum load	64260 g	32260 g	16260 g
Taring range	260 g	260 g	260 g
Repeatability	0.4 mg	0.2 mg	0.2 mg
Linearity (el. weighing range)	0.5 mg	0.5 mg	0.5 mg
Stabilization time (typical)	25...50 s	25...50 s	25...50 s
Built-in dial weights	250 g, 250 g, 250 g, 250 g 500 g, 500 g 2 kg, 2 kg, 2 kg 8 kg, 8 kg 8 kg, 8 kg 8 kg, 8 kg, 8 kg	250 g, 250 g, 250 g, 250 g 500 g, 500 g 2 kg, 2 kg, 2 kg 4 kg, 4 kg 8 kg, 8 kg	250 g, 250 g, 250 g, 250 g 500 g, 500 g 2 kg, 2 kg, 2 kg 4 kg, 4 kg
Adjusting weights			
Internal weights	250 g	250 g	250 g
External weights	200 g	200 g	200 g
Dimensions of measuring weights			
min. ø	40 mm	40 mm	40 mm
max. ø	340 mm	340 mm	340 mm
max. height	350 mm	350 mm	350 mm
Levelmatic automatic centering	built in	built in	built in
Dimensions of balance/handler			
Balance (WxDxH) [cm]	120 x 120 x 150	120 x 120 x 150	120 x 120 x 150
Weight	290 kg	290 kg	290 kg
Balance controller (WxDxH) [cm]	22.4 x 36.6 x 9.4	22.4 x 36.6 x 9.4	22.4 x 36.6 x 9.4
Weight	2.5 kg	2.5 kg	2.5 kg
Controller Rack (WxDxH) [cm]			
Rack empty	65 x 60 x 130	65 x 60 x 130	65 x 60 x 130
with process controller	65 x 60 x 160	65 x 60 x 160	65 x 60 x 160
Weight	50 kg	50 kg	50 kg



## 10.3 Dimensions

### 10.3.1 Balance with Handler (mm)

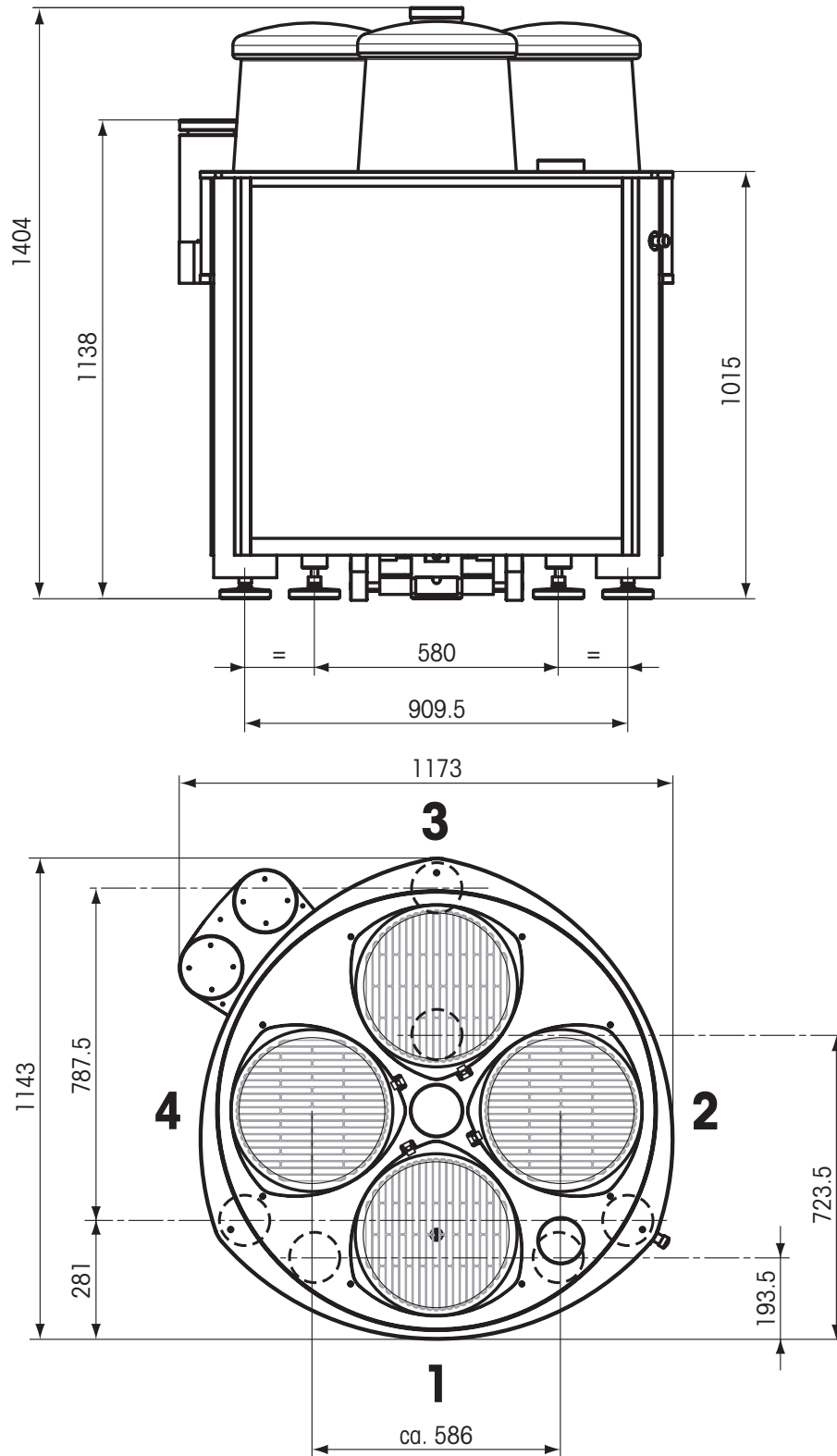

### 10.3.2 Rack with Controller (mm)

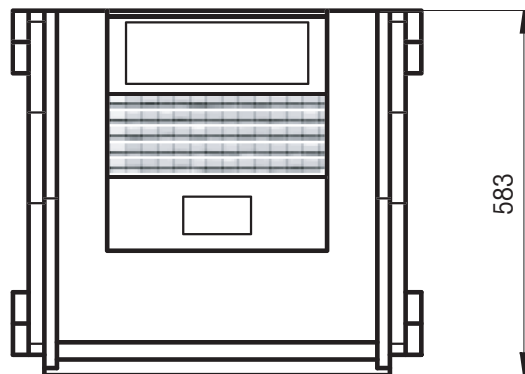
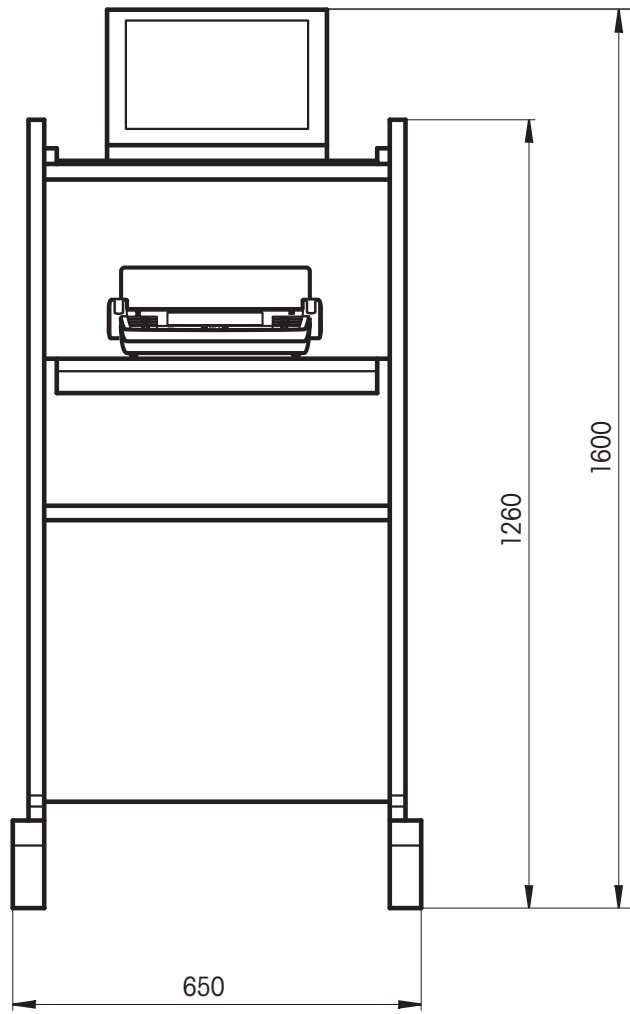

## 10.4 Specifications of the RS232C Interface

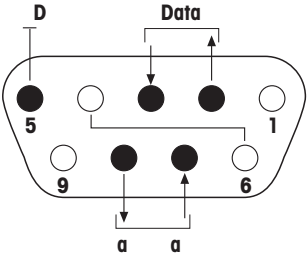
Interface type:	Voltage interface according to EIA RS-232C/DIN 66020 (CCITT V24/V.28)	
Max. cable length:	15 m	
Signal level:	Outputs: +5 V ... +15 V (RL = 3 – 7 kΩ) –5 V ... –15 V (RL = 3 – 7 kΩ)	Inputs: +3 V ... 25 V –3 V ... 25 V
Connector:	Sub-D, 9-pole, female	
Operating mode:	Full duplex	
Transmission mode:	Bit-serial, asynchronous	
Transmission code:	ASCII	
Baud rates:	150, 300, 600, 1200, 2400, 4800, 9600, 19200 (firmware selectable)	
Bits/parity:	7-bit/even, 7-bit/odd, 7-bit/none, 8-bit/none (firmware selectable)	
Stop bits:	1 stop bit	
Handshake:	None, XON/XOFF, RTS/CTS (firmware selectable)	
End-of-line:	<CR><LF>, <CR>, <LF> (firmware selectable)	
	<p>Pin 2: Balance transmit line (TxD)  Pin 3: Balance receive line (RxD)  Pin 5: Ground signal (GND)  Pin 7: Clear to send (hardware handshake) (CTS)  Pin 8: Request to send (hardware handshake) (RTS)</p>	

## 10.5 Accessories

You can increase the functionality of your balance with accessories from the METTLER TOLEDO range. The following options are available:

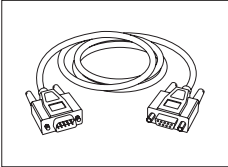
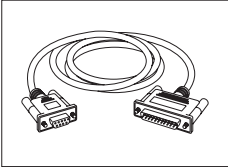
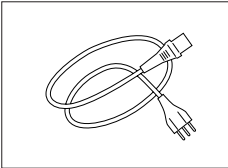
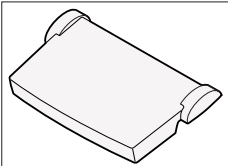
	Description	Part No.
<b>Cable for RS232C interface</b>		
	RS9 – RS9 (m/f), connection cable for PC, length = 1 m	11101051
	RS9 – RS25 (m/f), connection cable for PC, length = 2 m	11101052
<b>Power cable</b>		
	Country-specific 3-Pin power cable with grounding conductor.	
	Power cable AU	00088751
	Power cable BR	30015268
	Power cable CH	00087920
	Power cable CN	30047293
	Power cable DK	00087452
	Power cable EU	00087925
	Power cable GB	00089405
	Power cable IL	00225297
	Power cable IN	11600569
	Power cable IT	00087457
	Power cable JP	11107881
	Power cable TH, PE	11107880
	Power cable US	00088668
	Power cable ZA	00089728
<b>Protective covers</b>		
	Protective cover for terminal	11100830

**Description**

**Part No.**

**Climatic measurement station Klimet A30**



Klimet A30 certified  
Includes: 1 sensor for air temperature, 1 sensor for air pressure,  
1 sensor for relative humidity.

00222012



Klimet A30 not certified  
Includes: 1 sensor for air temperature, 1 sensor for air pressure,  
1 sensor for relative humidity.

00222011



Temperature sensor (with 5 m cable)  
Mounting for temperature sensor  
Cable guide for temperature sensor

00222014  
on request  
on request

**Draft shield**

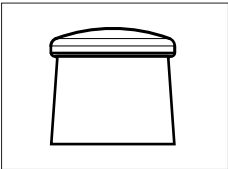

Glass cylinder

on request

**Software**

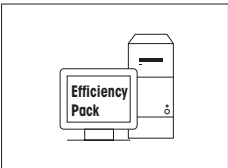

Efficiency Pack

11116875

# 11 Index

## A

AC adapter 8, 12  
AC Adapter 47  
Accessories 8, 52  
Adjustment 21, 34  
Adjustment and test reports 22  
Adjustment with external weight 41  
Adjustment with internal weight 40  
Application 17, 18, 32, 38

## B

Balance controller 39  
Balance identification 37  
Balance information 31  
Battery 30  
Beep 27  
Brightness of the display 27

## C

Checking the adjustment with the external weight 43  
Checking the adjustment with the internal weight 42  
Cleaning 45  
Connection diagram 10  
Contrast of the display 27  
Conventions 6

## D

Date 17, 29, 37  
Date formats 29  
Delivered items 9  
Dimensions 49  
Display 17  
Disposal 45

## E

Energy-saving function 30  
Environmental conditions 24, 46  
Error messages 44  
External adjustment weight 23  
External test weight 23

## F

Factory settings 28  
Function keys 17, 34

## H

Help function 16  
History 21

## I

Information field 35  
Information fields 17

## K

Keys 16

## L

Lettertype 27  
Level indicator 11  
Levelmatic 38  
Location 11

## M

Measurement value 24  
Model-specific data 48

## N

Nominal weight 34, 35, 39

## O

Operating 18  
Overload 44

## P

Peripheral 8  
Peripheral devices 25  
Power supply 46  
Power supply voltage 8, 12

## R

Reading angle 13  
Repeatability 24  
Report 37  
RS232C interface 51

## S

Safety information 7  
Self test 12  
Settings 18  
SmartSens 16  
SmartTrac 17, 35  
Standby 30  
Stopwatch 17, 35  
Switch the weighing system off 15  
Switch the weighing system on 15  
System settings 20

## T

Technical data 46  
Terminal 16

Test 21  
Time 17, 29, 37  
Time formats 29  
Touch function 28  
Touch Screen 17, 28

## U

Underload 44

## W

Weighing mode 24  
Weighing parameters 24  
Weighing result 17  
Weighing unit 17, 36  
Weight certificate 23  
Weight identification 23



## **GWP® – Good Weighing Practice™**

The global weighing guideline GWP® reduces risks associated with your weighing processes and helps to

- choose the appropriate balance
- reduce costs by optimizing testing procedures
- comply with the most common regulatory requirements

► [www.mt.com/GWP](http://www.mt.com/GWP)

[www.mt.com/comparators](http://www.mt.com/comparators)

For more information

### **Mettler-Toledo AG Laboratory & Weighing Technologies**

CH-8606 Greifensee, Switzerland

Tel. +41 (0)44 944 22 11

Fax +41 (0)44 944 30 60

Internet: [www.mt.com](http://www.mt.com)

Subject to technical changes.  
© Mettler-Toledo AG 08/2013  
11780468D en



\* 1 1 7 8 0 4 6 8 \*